

ABB GENERAL PURPOSE DRIVES

ACS480 drives

Hardware manual



ACS480 drives

Hardware manual

Table of contents



1. Safety instructions



4. Mechanical installation



6. Electrical installation – IEC



Table of contents

1 Safety instructions

Contents of this chapter	13
Use of warnings and notes	13
General safety in installation, start-up and maintenance	14
Electrical safety in installation, start-up and maintenance	14
Electrical safety precautions	14
Additional instructions and notes	15
Printed circuit boards	16
Grounding	16
General safety in operation	17
Additional instructions for permanent magnet motor drives	17
Safety in installation, start-up, maintenance	17
Safety in operation	18

2 Introduction to the manual

Contents of this chapter	19
Applicability	19
Target audience	19
Purpose of the manual	19
Categorization by frame size	19
Quick installation and commissioning flowchart	20
Terms and abbreviations	21
Related manuals	22

3 Operation principle and hardware description

Contents of this chapter	25
Operation principle	25
Simplified main circuit diagram	26
Product variants	26
IEC and UL (NEC) product types	26
Layout	27
Control connections	28
Standard unit	28
Base unit	29
Option modules	29
Control panel options	30
UL Type 1 kits	30
Drive labels	31
Type designation key	32
Basic code	32
Option (plus) codes	32

4 Mechanical installation

Contents of this chapter	35
Installation alternatives	35



Examining the installation site	36
Required tools	36
Unpacking the delivery	36
Installing the drive	37
To install the drive with screws	37
To install the drive to a DIN installation rail	37
5 Guidelines for planning the electrical installation	
Contents of this chapter	39
Limitation of liability	39
Selecting the main supply disconnecting device	39
European Union	39
North America	40
Other regions	40
Selecting the main contactor	40
Checking the compatibility of the motor and drive	40
Selecting the power cables	40
General guidelines	40
Typical power cable sizes	41
Power cable types	41
Preferred power cable types	41
Alternate power cable types	42
Not allowed power cable types	42
Additional guidelines, North America	43
Metal conduit	43
Power cable shield	43
Selecting the control cables	44
Shielding	44
Signals in separate cables	44
Signals that can be run in the same cable	44
Relay cable type	44
Control panel to drive cable	45
Routing the cables	45
General guidelines – IEC	45
General guidelines – North America	45
Continuous motor cable shield/conduit or enclosure for equipment on the motor cable	46
Separate control cable ducts	47
Implementing short-circuit and thermal overload protection	47
Protecting the drive and input power cable in short-circuits	47
Protecting the motor and motor cable in short-circuits	47
Protecting the drive, and the input power and motor cables against thermal overload	47
Protecting the motor against thermal overload	47
Protecting the motor against overload without thermal model or temperature sensors	48
Implementing a motor temperature sensor connection	48
Protecting the drive against ground faults	49
Residual current device compatibility	49
Implementing the Emergency stop function	49
Implementing the Safe torque off function	49
Using a safety switch between the drive and the motor	49



Implementing the control of a contactor between drive and motor	49
Protecting the contacts of relay outputs	50
6 Electrical installation – IEC	
Contents of this chapter	51
Warnings	51
Required tools	51
Measuring the insulation	52
Measuring the insulation of the drive system	52
Measuring the insulation of the input cable	52
Measuring the insulation of the motor and motor cable	52
Measuring the insulation of brake resistor and resistor cable	52
Earthing system compatibility check – IEC	53
EMC filter compatibility	53
Ground-to-phase varistor compatibility	53
When to disconnect EMC filter or ground-to-phase varistor	53
Disconnecting the EMC filter or ground-to-phase varistor	54
Identifying the earthing system of the electrical power network	55
Connecting the power cables – IEC (shielded cables)	56
Connection diagram	56
Connection procedure	57
Connecting the control cables	58
Default I/O connection diagrams (ABB standard macro)	58
Default fieldbus connection diagram	60
Control cable connection procedure	61
Additional information on the control connections	62
Connecting EIA-485 fieldbus cable to the drive	62
Connection examples of two-wire and three-wire sensors	62
AI and AO (or AI, DI and +10 V) as PTC motor temperature sensor interface ...	63
AI1 and AI2 as Pt100, Pt1000, Ni1000, KTY83 and KTY84 sensor inputs	64
Auxiliary voltage connection	65
Connecting a PC	66
Installing options	66
Installing a front option	66
Installing a side option	67
7 Electrical installation – North America	
Contents of this chapter	69
Warnings	69
Required tools	69
Measuring the insulation	70
Measuring the insulation of the drive system	70
Measuring the insulation of the input cable	70
Measuring the insulation of the motor and motor cable	70
Measuring the insulation of brake resistor and resistor cable	70
Earthing system compatibility check – North America	71
EMC filter	71
Ground-to-phase varistor	71
When to disconnect ground-to-phase varistor, or connect EMC filter	71
Disconnecting the ground-to-phase varistor, or connecting the EMC filter	73
Identifying the earthing system of the electrical power network	73



Connecting the power cables – North America (wiring in conduits)	74
Connection diagram	75
Connection procedure	75
Connecting the control cables	76
Default I/O connection diagrams (ABB standard macro)	76
Default fieldbus connection diagram	78
Control cable connection procedure	79
Additional information on the control connections	80
Connecting EIA-485 fieldbus cable to the drive	80
Connection examples of two-wire and three-wire sensors	80
AI and AO (or AI, DI and +10 V) as PTC motor temperature sensor interface ...	81
AI1 and AI2 as Pt100, Pt1000, Ni1000, KTY83 and KTY84 sensor inputs	82
Auxiliary voltage connection	83
Connecting a PC	84
Installing options	84
Installing a front option	84
Installing a side option	85
8 Installation checklist of the drive	
Contents of this chapter	87
Checklist	87
9 Maintenance	
Contents of this chapter	89
Maintenance intervals	89
Cleaning the heatsink	90
Replacing the cooling fans	91
To replace the cooling fan for frame sizes R1, R2 and R3	91
To replace the cooling fan for frame R4	92
Capacitors	94
Reforming the capacitors	94
10 Technical data	
Contents of this chapter	95
Electrical ratings	96
IEC ratings	96
UL (NEC) ratings	97
Notes and definitions	98
Sizing	98
Output derating	98
Surrounding air temperature derating	100
Switching frequency derating	100
Altitude derating	101
Fuses	102
gG fuses (IEC)	102
gR fuses (IEC)	102
T fuses (UL(NEC))	103
Alternate short-circuit protection	104
Miniature circuit breakers (IEC)	104
Manual self-protected combination motor controller – Type E USA (UL (NEC))	105
Dimensions and weights	106



Free space requirements	107
Losses, cooling data and noise	107
Terminal data for the power cables	109
Typical power cable sizes	110
Terminal data for the control cables	110
External EMC filters	111
Electrical power network specification	112
Motor connection data	112
Motor cable length	112
Operational functionality and motor cable length	112
EMC compatibility and motor cable length	113
Brake resistor connection data	113
Control connection data	114
Efficiency	114
Protection classes	115
Ambient conditions	115
Materials	116
Disposal	116
Applicable standards	116
Markings	117
EMC compliance (IEC/EN 61800-3:2004 + A2012)	117
Definitions	117
Category C1	118
Category C2	118
Category C3	119
Category C4	119
UL and CSA checklist	120
Disclaimers	121
Generic disclaimer	121
Cybersecurity disclaimer	121
11 Dimension drawings	
Contents of this chapter	123
Frame R1	124
Frame R1 (front & side) - IP20 / UL type open	124
Frame R1 (bottom & rear) - IP20 / UL type open	125
Frame R1 (front & side) - UL type 1 kit installed	126
Frame R1 (bottom & rear) - UL type 1 kit installed	127
Frame R2	128
Frame R2 (front & side) - IP20 / UL type open	128
Frame R2 (bottom & rear) - IP20 / UL type open	129
Frame R2 (front & side) - UL type 1 kit installed	130
Frame R2 (bottom & rear) - UL type 1 kit installed	131
Frame R3	132
Frame R3 (front & side) - IP20 / UL type open	132
Frame R3 (bottom & rear) - IP20 / UL type open	133
Frame R3 (front & side) - UL type 1 kit installed	134
Frame R3 (bottom & rear) - UL type 1 kit installed	135
Frame R4	136
Frame R4 (front & side) - IP20 / UL type open	136
Frame R4 (bottom & rear) - IP20 / UL type open	137
Frame R4 (front & side) - UL type 1 kit installed	138



Frame R4 (bottom & rear) - UL type 1 kit installed	139
--	-----

12 Resistor braking

Contents of this chapter	141
Safety	141
Operating principle	141
Selecting the brake resistor	141
Reference brake resistors	143
Definitions	143
Selecting and routing the brake resistor cables	144
Minimizing electromagnetic interference	144
Maximum cable length	144
Placing custom brake resistors	144
Protecting the system in brake circuit fault situations	144
Protecting the system in cable and brake resistor short-circuit situations	144
Protecting the system against thermal overload	145
Mechanical and electrical installation of brake resistor	145
Mechanical installation	146
Electrical installation	146
Measuring the insulation	146
Connecting power cables	146
Connection the control cables	146
Start-up	146

13 The Safe torque off function

Contents of this chapter	147
Description	147
Compliance with the European Machinery Directive	148
Wiring	149
Connection principle	149
Single ACS480 drive, internal power supply	149
Single ACS480 drive, external power supply	150
Wiring examples	150
Single ACS480 drive, internal power supply	150
Single ACS480 drive, external power supply	151
Multiple ACS480 drives, internal power supply	152
Multiple ACS480 drives, external power supply	153
Activation switch	153
Cable types and lengths	153
Grounding of protective shields	154
Operation principle	155
Start-up including acceptance test	156
Competence	156
Acceptance test reports	156
Acceptance test procedure	156
Use	158
Maintenance	159
Competence	159
Fault tracing	160
Safety data	161
Abbreviations	161

TÜV certificate	162
Declaration of conformity	163
14 BAPO-01 auxiliary power extension module	
Contents of this chapter	165
Safety instructions	165
Hardware description	165
Layout	166
Mechanical installation	166
Electrical installation	166
Start-up	167
Technical data	167
15 BIO-01 I/O extension module	
Contents of this chapter	169
Safety instructions	169
Hardware description	169
Product overview	169
Layout	170
Mechanical installation	170
Electrical installation	170
Start-up	171
Technical data	171
16 BREL-01 relay output extension module	
Contents of this chapter	173
Safety instructions	173
Hardware description	173
Product overview	173
Layout	174
Mechanical installation	174
Electrical installation	174
Start-up	175
Configuration parameters	175
Technical data	177
<i>Further information</i>	





1

Safety instructions



Contents of this chapter

This chapter contains the safety instructions which you must obey when you install, start up, operate and do maintenance work on the drive. If you ignore the safety instructions, injury, death or damage can occur.

Use of warnings and notes

Warnings tell you about conditions which can cause injury or death, or damage to the equipment. They also tell you how to prevent the danger. Notes draw attention to a particular condition or fact, or give information on a subject.

The manual uses these warning symbols:

**WARNING!**

Electricity warning tells about hazards from electricity which can cause injury or death, or damage to the equipment.

**WARNING!**

General warning tells about conditions, other than those caused by electricity, which can cause injury or death, or damage to the equipment.

**WARNING!**

Electrostatic sensitive devices warning tells you about the risk of electrostatic discharge which can cause damage to the equipment.

General safety in installation, start-up and maintenance

These instructions are for all personnel who do work on the drive.



WARNING!

Obey these instructions. If you ignore them, injury or death, or damage to the equipment can occur.

- Keep the drive in its package until you install it. After unpacking, protect the drive from dust, debris and moisture.
- Use the required personal protective equipment: safety shoes with metal toe cap, safety glasses, protective gloves, etc.
- Beware of hot surfaces. Some parts, such as heatsinks of power semiconductors, and brake resistors, remain hot for a while after disconnection of the electrical supply.
- Vacuum clean the area around the drive before the start-up to prevent the drive cooling fan from drawing the dust inside the drive.
- Make sure that debris from drilling, cutting and grinding does not enter the drive during the installation. Electrically conductive debris inside the drive may cause damage or malfunction.
- Make sure that there is sufficient cooling. See the technical data.
- Before you connect voltage to the drive, make sure that all covers are in place. Do not remove the covers when voltage is connected.
- Before you adjust the drive operation limits, make sure that the motor and all driven equipment can operate throughout the set operation limits.
- Before you activate the automatic fault reset or automatic restart functions of the drive control program, make sure that no dangerous situations can occur. These functions reset the drive automatically and continue operation after a fault or supply break. If these functions are activated, the installation must be clearly marked as defined in IEC/EN 61800-5-1, subclause 6.5.3, for example, "THIS MACHINE STARTS AUTOMATICALLY".
- The maximum drive power cycles is five times in ten minutes. Power cycling the drive too often can damage the charging circuit of the DC capacitors.
- Validate any safety circuits (for example, Safe torque off or emergency stop) in start-up. See separate instructions for the safety circuits.
- Beware of hot air exiting from the air outlets.
- Do not cover the air inlet or outlet when the drive is running.

Note:

- If you select an external source for the start command and it is on, the drive will start immediately after fault reset unless you configure the drive for pulse start. See the firmware manual.
- Depending on the wiring and parametrization of the drive, the stop key on the control panel may not stop the drive.
- Only authorized persons are allowed to repair a malfunctioning drive.

Electrical safety in installation, start-up and maintenance

■ Electrical safety precautions

These electrical safety precautions are for all personnel who do work on the drive, motor cable or motor.

**WARNING!**

Obey these instructions. If you ignore them, injury or death, or damage to the equipment can occur.

If you are not a qualified electrician, do not do installation or maintenance work.

Go through these steps before you begin any installation or maintenance work.

1. Clearly identify the work location and equipment.
2. Disconnect all possible voltage sources. Make sure that re-connection is not possible. Lock out and tag out.
 - Open the main disconnecting device of the drive.
 - If you have a permanent magnet motor connected to the drive, disconnect the motor from the drive with a safety switch or by other means.
 - Disconnect any dangerous external voltages from the control circuits.
 - After you disconnect power from the drive, always wait 5 minutes to let the intermediate circuit capacitors discharge before you continue.
3. Protect any other energized parts in the work location against contact.
4. Take special precautions when close to bare conductors.
5. Measure that the installation is de-energized.
 - Use a multimeter with an impedance greater than 1 Mohm.
 - Make sure that the voltage between the drive input power terminals (L1, L2, L3) and the grounding (PE) busbar is close to 0 V.
 - Make sure that the voltage between the drive DC terminals (R+/UDC+ and UDC-) and the grounding terminal (PE) is close to 0 V.
 - Make sure that the voltage between the drive output terminals (T1/U, T2/V, T3/W) and the grounding (PE) busbar is close to 0 V.
6. Install temporary grounding as required by the local regulations.
7. Ask the person in control of the electrical installation work for a permit to work.

■ Additional instructions and notes

**WARNING!**

Obey these instructions. If you ignore them, injury or death, or damage to the equipment can occur.

If you are not a qualified electrician, do not do installation or maintenance work.

- Make sure that the electrical power network, motor/generator, and environmental conditions agree with the drive data.
- Do not do insulation or voltage withstand tests on the drive.

Note:

- The motor cable terminals of the drive are at a dangerous voltage when the input power is on, regardless of whether the motor is running or not.
- When the input power is on, the drive DC bus is at a dangerous voltage. If brake chopper and resistor are in use, they are at a dangerous voltage.



- External wiring can supply dangerous voltages to the relay outputs of the control units of the drive.
- The Safe torque off function does not remove the voltage from the main and auxiliary circuits. The function is not effective against deliberate sabotage or misuse.

Printed circuit boards



WARNING!

Use a grounding wrist band when you handle printed circuit boards. Do not touch the boards unnecessarily. The boards contain components sensitive to electrostatic discharge.

■ Grounding

These instructions are for all personnel who are responsible for the grounding of the drive.



WARNING!

Obey these instructions. If you ignore them, injury or death, or equipment malfunction can occur, and electromagnetic interference can increase.

If you are not a qualified electrician, do not do grounding work.



- Always ground the drive, the motor and adjoining equipment. This is necessary for the personnel safety. Proper grounding also reduces electromagnetic emission and interference.
- Make sure that the conductivity of the protective earth (PE) conductors is sufficient. See the electrical planning instructions of the drive. Obey the local regulations.
- Connect the power cable shields to protective earth (PE) terminals of the drive to make sure of personnel safety.
- Make a 360° grounding of the power and control cable shields at the cable entries to suppress electromagnetic disturbances.
- In a multiple-drive installation, connect each drive separately to the protective earth (PE) busbar of the power supply.

Note:

- You can use power cable shields as grounding conductors only when their conductivity is sufficient.
- As the normal touch current of the drive is higher than 3.5 mA AC or 10 mA DC, you must use a fixed protective earth (PE) connection. The minimum size of the protective earth conductor must comply with the local safety regulations for high protective earth conductor current equipment. See standard IEC/EN 61800-5-1 (UL 61800-5-1) and the electrical planning instructions of the drive.

In addition:

- use a protective earth conductor with a cross-section of at least 10 mm² Cu or 16 mm² Al,
or
 - use a second protective earth conductor of the same cross-sectional area as the original protective earth conductor,
or
 - use a device which automatically disconnects the supply if the protective earth conductor breaks.
-

If the protective earth conductor is separate (ie, it does not form part of the input power cable or the input power cable enclosure), the cross section must be at least:

- 2.5 mm² (14 AWG) when the conductor is mechanically protected, or
- 4 mm² (12 AWG) when the conductor is not mechanically protected.

General safety in operation

These instructions are for all personnel that operate the drive.



WARNING!

Obey these instructions. If you ignore them, injury or death, or damage to the equipment can occur.

- Give a stop command to the drive before you reset a fault. If you have an external source for the start command and the start is on, the drive will start immediately after the fault reset, unless you configure the drive for pulse start. See the firmware manual.
- Before you activate the automatic fault reset or automatic restart functions of the drive control program, make sure that no dangerous situations can occur. These functions reset the drive automatically and continue operation after a fault or supply break. If these functions are activated, the installation must be clearly marked as defined in IEC/EN 61800-5-1, subclause 6.5.3, for example, "THIS MACHINE STARTS AUTOMATICALLY".

Note:

- The maximum drive power cycles is five times in ten minutes. Power cycling the drive too often can damage the charging circuit of the DC capacitors. If you need to start or stop the drive, use the control panel start and stop keys or commands through the I/O terminals of the drive.
- Depending on the wiring and parametrization of the drive, the stop key on the control panel may not stop the drive.

Additional instructions for permanent magnet motor drives

■ Safety in installation, start-up, maintenance

These are additional warnings concerning permanent magnet motor drives. The other safety instructions in this chapter are also valid.



WARNING!

Obey these instructions. If you ignore them, injury or death, or damage to the equipment can occur.

If you are not a qualified electrician, do not do installation or maintenance work.

- Do not do work on the drive when a rotating permanent magnet motor is connected to it. A rotating permanent magnet motor energizes the drive including its input and output power terminals.

Before installation, start-up and maintenance work on the drive:

- Stop the drive.
- Disconnect the motor from the drive with a safety switch or by other means.

- If you cannot disconnect the motor, make sure that the motor cannot rotate during work. Make sure that no other system, like hydraulic crawling drives, can rotate the motor directly or through any mechanical connection like belt, nip, rope, etc.
- Do the steps in section *Electrical safety precautions (page 14)*
- Measure that the installation is de-energized.
 - Use a multimeter with an impedance greater than 1 Mohm.
 - Make sure that the voltage between the drive output terminals (T1/U, T2/V, T3/W) and the grounding (PE) busbar is close to 0 V.
 - Make sure that the voltage between the drive input power terminals (L1, L2, L3) and the grounding (PE) busbar is close to 0 V.
 - Make sure that the voltage between the drive DC terminals (R+/UDC+ and UDC-) and the grounding terminal (PE) is close to 0 V.
- Install temporary grounding to the drive output terminals (U2, V2, W2). Connect the output terminals together as well as to the PE.

During the start up:

- Make sure that the motor cannot be run into overspeed, eg, driven by the load. Motor overspeed causes overvoltage that can damage or destroy the capacitors in the intermediate circuit of the drive.



■ Safety in operation



WARNING!

Make sure that the motor cannot be run into overspeed, e.g. driven by the load. Motor overspeed causes overvoltage that can damage or destroy the capacitors in the intermediate circuit of the drive.



Introduction to the manual

Contents of this chapter

The chapter describes the manual: the applicability, target audience and purpose of the manual. The chapter contains a list of related manuals and a flowchart for installation and commissioning.

Applicability

The manual applies to ACS480 drives.

Target audience

The reader is expected to know the fundamentals of electricity, wiring, electrical components and electrical schematic symbols.

The manual is written for readers worldwide. Both SI and imperial units are shown.

Purpose of the manual

This manual gives information needed to plan the installation, install, commission and service the drive.

Categorization by frame size

The drives is manufactured in frame sizes, for example, R1, R2 and so on. The information that is applicable only to certain frames is labelled with the frame size. The frame size is marked on the type designation label.

Quick installation and commissioning flowchart

Task	See
Identify the frame size: R1, R2, etc.	<i>Type designation key (page 32)</i>
↓	
Plan the installation. Check the ambient conditions, ratings and required cooling air flow.	<i>Guidelines for planning the electrical installation (page 39)</i> <i>Technical data (page 95)</i>
↓	
Unpack and check the delivery.	<i>Unpacking the delivery (page 36)</i>
↓	
If the drive will be connected to an electrical power network other than a symmetrically grounded TN-S system, make sure of the compatibility.	<i>Earthing system compatibility check – IEC (page 53)</i>
↓	
Install the drive.	<i>Installing the drive (page 37)</i>
↓	
Route the cables.	<i>Routing the cables (page 45)</i>
↓	
Measure the insulation of the input cable, motor and motor cable.	<i>Measuring the insulation (page 52)</i>
↓	
Connect the power cables.	<i>Connecting the power cables – IEC (shielded cables) (page 56)</i> <i>Connecting the power cables – North America (wiring in conduits) (page 74)</i>
↓	
Connect the control cables.	<i>Connecting the control cables (page 58)</i>
↓	
Examine the installation.	<i>Installation checklist of the drive (page 87)</i>
↓	
Commission the drive.	Refer to the <i>ACS480 Quick installation and start-up guide</i> (3AXD50000047400 [English]) and the <i>ACS480 Firmware manual</i> (3AXD50000047399 [English]).

Terms and abbreviations

Term	Description
ACS-AP-x	Assistant control panel
BAPO	Optional auxiliary power extension module
BCBL-01	Optional USB to RJ45 cable
BIO-01	Optional I/O extension module. Can be installed to the drive together with a fieldbus adapter module.
Brake chopper	Conducts the surplus energy from the intermediate circuit of the drive to the brake resistor when necessary. The chopper operates when the DC link voltage exceeds a certain maximum limit. The voltage rise is typically caused by deceleration (braking) of a high inertia motor.
Brake resistor	Dissipates the drive surplus braking energy conducted by the brake chopper to heat
BREL	Optional relay output extension module
Capacitor bank	The capacitors connected to the DC link
CCA-01	Configuration adapter
CDPI-01	Communication adapter module
Control board	Circuit board in which the control program runs
DC link	DC circuit between rectifier and inverter
DC link capacitors	Energy storage which stabilizes the intermediate circuit DC voltage
Drive	Frequency converter for controlling AC motors
EFB	Embedded fieldbus
EMC	Electromagnetic compatibility
FBA	Fieldbus adapter
FCAN	Optional CANopen® adapter module
FCNA-01	Optional ControlNet™ adapter module
FDNA-01	Optional DeviceNet™ adapter module
FECA-01	Optional EtherCAT® adapter module
FEIP-21	Optional Ethernet adapter module
FENA-21	Optional Ethernet adapter module for EtherNet/IP™, Modbus TCP® and PROFINET IO® protocols, 2-port
FEPL-02	Optional Ethernet POWERLINK adapter module
FMBT-21	Optional Ethernet adapter module for Modbus TCP protocol
FPBA-01	Optional PROFIBUS DP® adapter module
FPNO-21	Optional Profinet IO adapter module
Frame, frame size	Physical size of the drive or power module
Intermediate circuit	DC circuit between rectifier and inverter
Inverter	Converts direct current and voltage to alternating current and voltage.
Macro	A pre-defined set of default values of parameters in a drive control program.
NETA-21	Remote monitoring tool
Parameter	In the drive control program, user-adjustable operation instruction to the drive, or signal measured or calculated by the drive. In some (for example fieldbus) contexts, a value that can be accessed as an object, eg, variable, constant, or signal.
PLC	Programmable logic controller
RFI	Radio-frequency interference
RIIO-01	Inbuilt I/O module
SIL	Safety integrity level (1...3) (IEC 61508)
STO	Safe torque off (IEC/EN 61800-5-2)

Related manuals

Name	Code
Drive manuals and guides	
<i>ACS480 drives hardware manual</i>	3AXD50000047392
<i>ACS480 quick installation and start-up guide</i>	3AXD50000047400
<i>ACS480 standard control program firmware manual</i>	3AXD50000047399
Option manuals or guides	
<i>ACx-AP-x assistant control panel user's manual</i>	3AUA0000085685
<i>ACS-BP-S basic control panel user's manual</i>	3AXD50000032527
<i>DPMP-01 mounting platform for ACx-AP-x control panel</i>	3AUA0000100140
<i>DPMP-02/03 mounting platform for ACx-AP-x control panel</i>	3AUA0000136205
<i>CDPI-01/-02 panel bus adapter user's manual</i>	3AXD50000009929
<i>FEIP-21 Ethernet/IP adapter module quick guide</i>	3AXD50000158584
<i>FEIP-21 Ethernet/IP fieldbus adapter module user's manual</i>	3AXD50000158621
<i>FENA-21 Ethernet adapter module quick guide</i>	3AXD50000158522
<i>FMBT-21 Modbus/TCP adapter module quick guide</i>	3AXD50000158560
<i>FMBT-21 Modbus/TCP adapter module user's manual</i>	3AXD50000158607
<i>FPBA-01 PROFIBUS DP adapter module quick guide</i>	3AXD50000158188
<i>FPBA-01 PROFIBUS DP adapter module user's manual</i>	3AFE68573271
<i>FPNO-21 PROFINET adapter module quick guide</i>	3AXD50000158577
<i>FPNO-21 PROFINET fieldbus adapter module user's manual</i>	3AXD50000158614
<i>FDNA-01 DeviceNet adapter module quick guide</i>	3AXD50000158515
<i>FDNA-01 DeviceNet adapter user's manual</i>	3AFE68573360
<i>FCAN-01 CANopen adapter module quick guide</i>	3AXD50000158195
<i>FCAN-01 CANopen adapter module user's manual</i>	3AFE68615500
<i>FSCA-01 RS-485 adapter module quick guide</i>	3AXD50000158546
<i>FSCA-01 RS-485 adapter module user's manual</i>	3AUA0000109533
<i>FCNA-01 ControlNet adapter module quick guide</i>	3AXD50000158201
<i>FCNA-01 ControlNet adapter module user's manual</i>	3AUA0000141650
<i>FECA-01 EtherCAT adapter module quick guide</i>	3AXD50000158553
<i>FECA-01 EtherCAT adapter module user's manual</i>	3AUA0000068940
<i>FEPL-02 Ethernet POWERLINK adapter module quick guide</i>	3AXD50000158164
<i>FEPL-02 Ethernet POWERLINK adapter module user's manual</i>	3AUA0000123527
<i>UL type 1 kit for ACS380, ACH480 and ACS480 installation guide, frames R0 to R2</i>	3AXD50000235254
<i>UL type 1 kit for ACS380, ACH480 and ACS480 installation guide, frames R3 to R4</i>	3AXD50000242375
Tool and maintenance manuals	
<i>Drive composer PC tool user's manual</i>	3AUA0000094606
<i>Converter module capacitor reforming instructions</i>	3BFE64059629

See [collection of links to ACS480 manuals](#).



See <https://library.abb.com/en> for all ABB product documentation on the Internet.

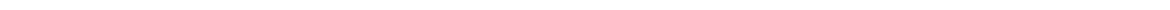



Operation principle and hardware description

Contents of this chapter

This chapter describes the operation principle, layout, type designation label and type designation information. It shows a general diagram of the power connections and control interfaces.

Operation principle

The ACS480 is a drive for controlling asynchronous AC induction motors, permanent magnet synchronous motors and ABB synchronous reluctance motors (SynRM motors). It is optimized for cabinet mounting.

■ **Simplified main circuit diagram**

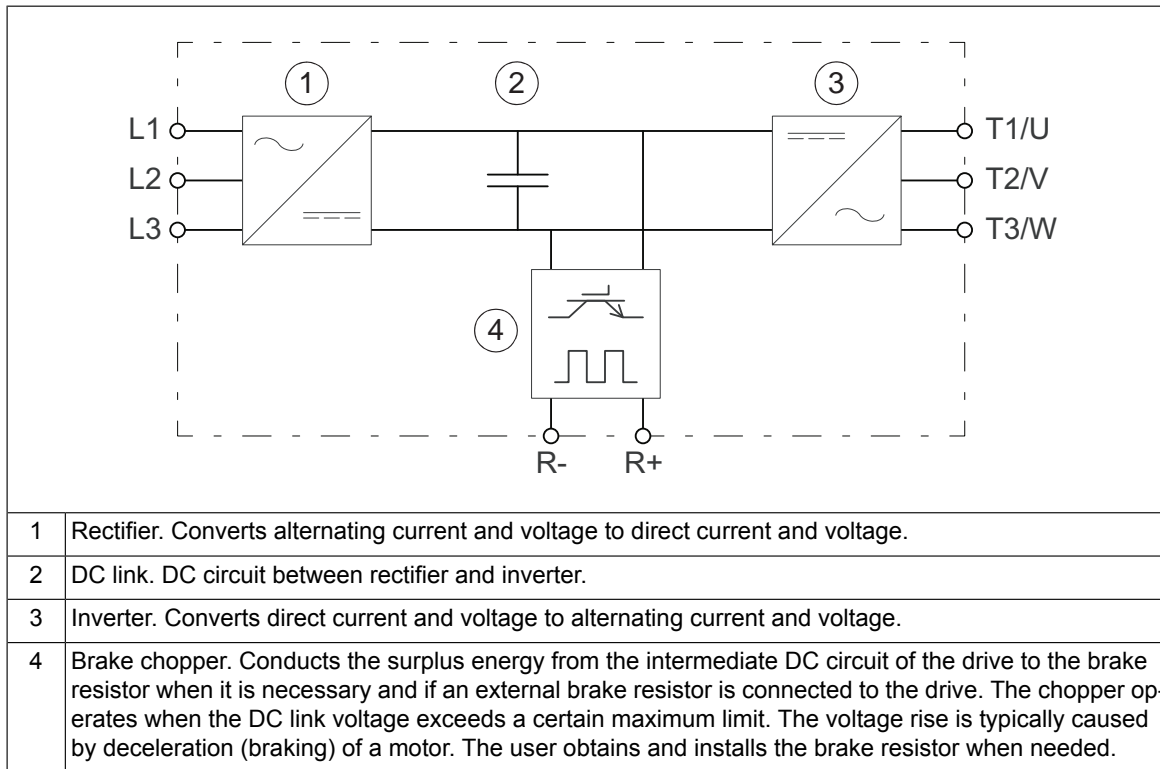

Product variants

The drive has two product variants:

- Standard unit: drive (for example, ACS480-04-02A7-4) with ACS-AP-S assistant control panel and I/O & EIA-485 module (RIIO-01).
- Base unit: drive (for example, ACS480-04-02A7-4+0J400+0L540) without control panel and without I/O & EIA-485 module (RIIO-01).

■ **IEC and UL (NEC) product types**

The ACS480 series consists of IEC product types and UL (NEC) product types. The IEC types are designed for global use. The UL (NEC) types are specifically designed for use in North America.

Layout

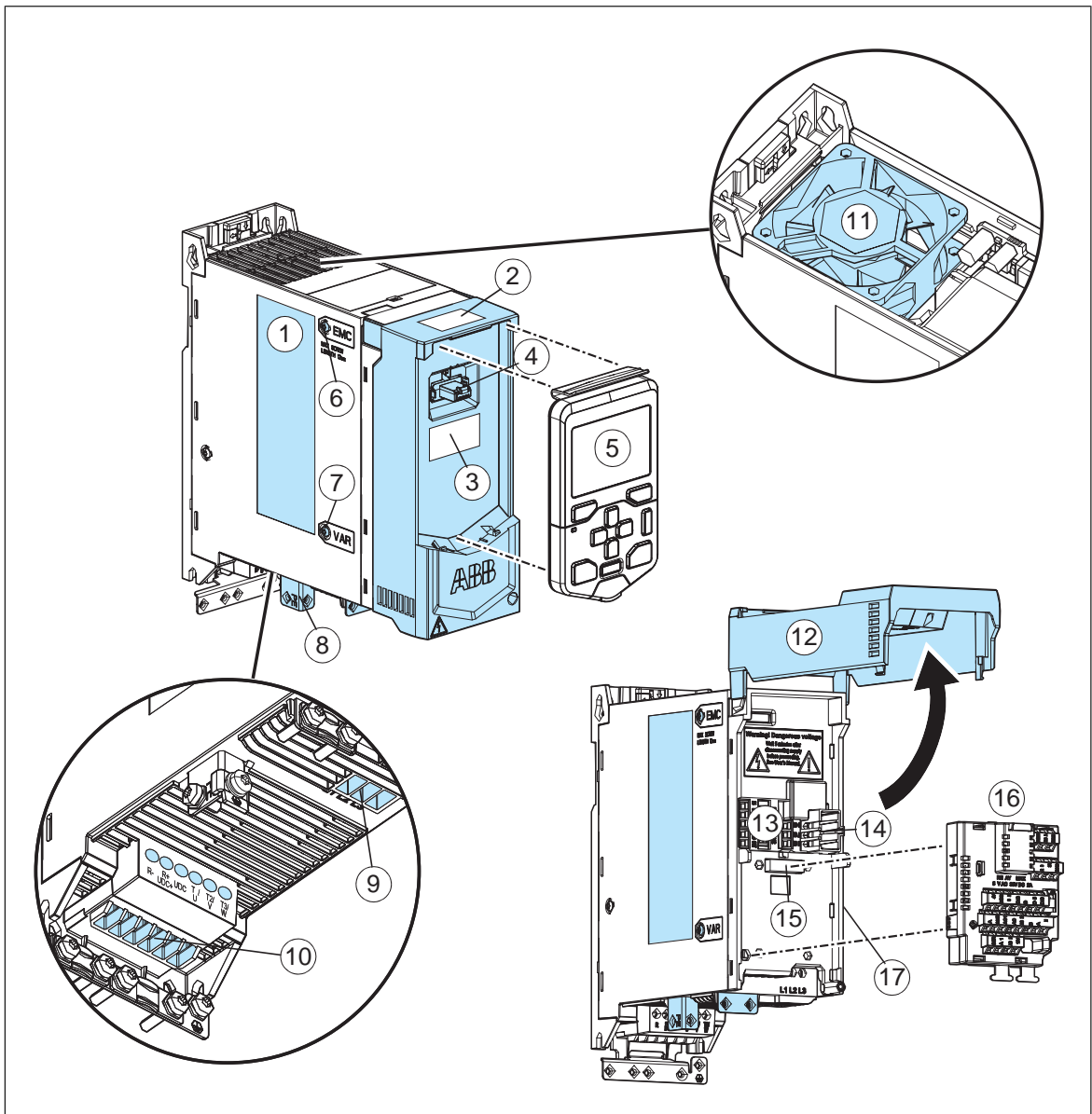

1	Type designation label	10	Motor and brake resistor terminals
2	Model information label	11	Cooling fan
3	Software information label	12	Front cover
4	Control panel connection	13	Fixed control terminals
5	Control panel	14	Cold configuration connection (CCA-01)
6	EMC filter grounding screw	15	Option slot for communication modules
7	Varistor grounding screw	16	I/O or fieldbus module
8	PE connection (motor)	17	Side option slot for side-mounted options
9	Input power terminal		

Control connections

There are fixed control connections on the base unit and optional control connections on the installed option module.

■ Standard unit

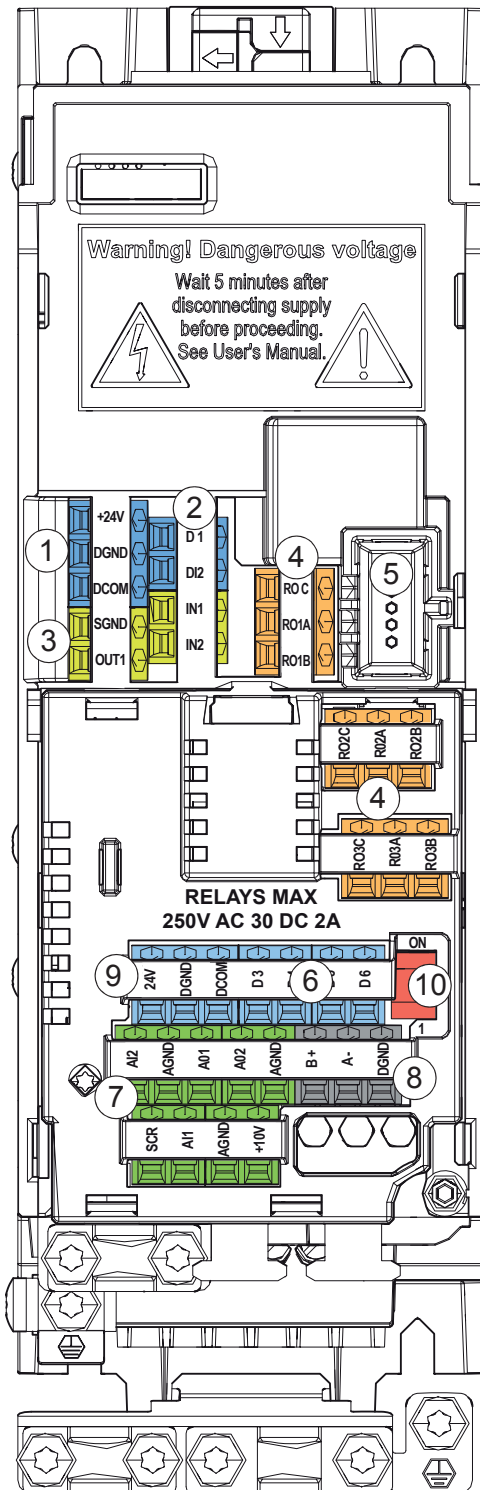

Connections of the base unit:

1. Auxiliary voltage outputs
2. Digital inputs
3. Safe torque-off connections
4. Relay output connections
5. Cold configuration connection for CCA-01

Connections of the RIIO-01 I/O & EIA-485 module:

6. Digital inputs
7. Analog inputs and outputs
8. Embedded fieldbus EIA-485 (Modbus RTU)
9. Auxiliary voltage output
10. EIA-485 end of line termination switch

■ **Base unit**

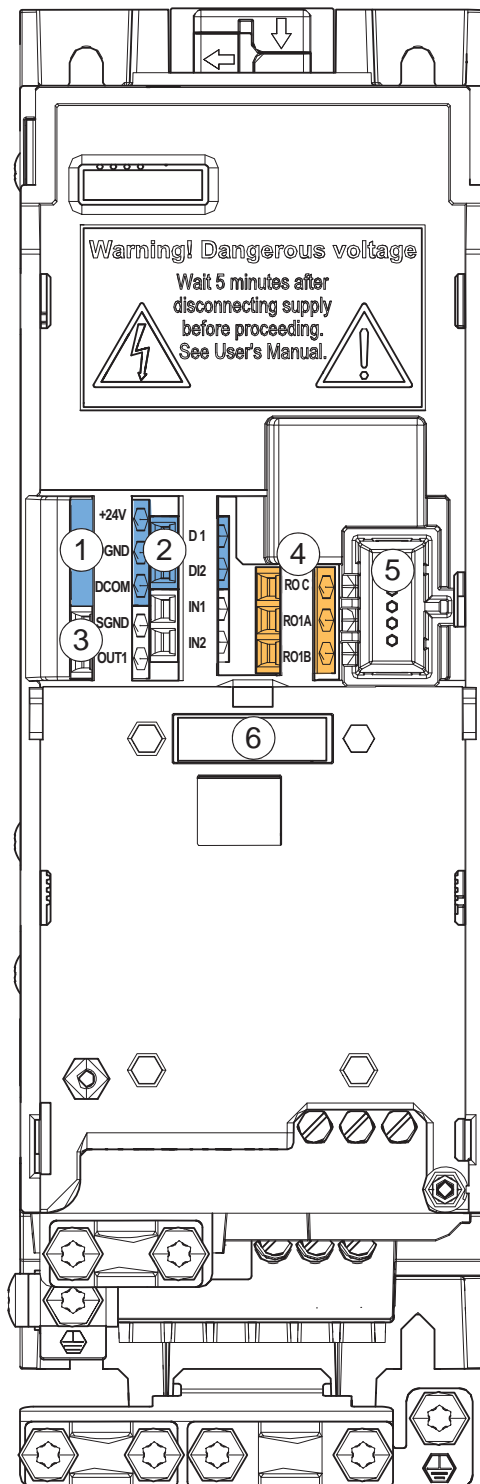

Connections of the base unit:

1. Auxiliary voltage outputs
2. Digital inputs
3. Safe torque-off connections
4. Relay output connection
5. Cold configuration connection for CCA-01
6. Front option module slot 1

Option modules

The drive can be equipped with various option module(s). See [Type designation key \(page 32\)](#).

Control panel options

The drive supports these control panels:

- ACS-AP-S assistant control panel
- ACS-AP-W assistant control panel with Bluetooth
- ACS-AP-I assistant control panel (for industrial drives)
- ACS-BP-S basic control panel
- RDUM-01 blank panel with RJ-45 connector
- CDPI-02 panel bus adapter (blank panel with two RJ-45 connectors for the panel bus).

In addition, you can order a control panel platform for the cabinet door installation. These panel platforms are available:

Type	Description
DPMP-01	Control panel mounting platform (flush mounting) and cable ¹⁾
DPMP-02	Control panel mounting platform (surface mounting) and cable ¹⁾
DPMP-EXT2	DPMP-02 panel mounting platform (and cable) and RDUM-01 blank panel with RJ-45 connector

¹⁾ You need also RDUM-01 blank panel, or CDPI-02 panel bus adapter to connect the panel cable at the drive end.

UL Type 1 kits

There are UL Type 1 kit options available for the drive. For more information, see:

- *UL Type 1 kit quick installation guide for ACS380, ACH480 and ACS480 – R0 to R2* (3AXD50000235254)
- *UL Type 1 kit quick installation guide for ACS380, ACH480 and ACS480 – R3 to R4* (3AXD50000242375).

Drive labels

The drive has these labels:

- Type designation label on the left side of the drive
- Model information label on the top of the drive
- Software information label under the front cover.

Type designation label, IEC																			
<p>ABB ACS480-04-02A7-4 (1)</p> <p>ABB Oy Hiomotie 13 00380 Helsinki Finland</p> <p>Input U1 3~ 400/480 VAC f1 50/60 Hz</p> <p>Output U2 3~ 0...U1 In 2.6/2.1 A Ild 2.5/2.1 A Ihd 1.8/1.6 A</p> <table border="1"> <tr> <th colspan="3">Input current is scaled by motor output current</th> </tr> <tr> <th>Output</th> <th>Input</th> <th>Input (with 5% choke)</th> </tr> <tr> <td>400/480 V</td> <td>400/480 V</td> <td>400/480 V</td> </tr> <tr> <td>In 2.6/2.1</td> <td>4.2/3.4</td> <td>2.6/2.1</td> </tr> <tr> <td>Ild 2.5/2.1</td> <td>4/3.4</td> <td>2.5/2.1</td> </tr> <tr> <td>Ihd 1.8/1.6</td> <td>2.9/2.6</td> <td>1.8/1.6</td> </tr> </table> <p>FRAME R1 (2)</p> <p>Air cooling</p> <p>IP20 Icc 100 kA (3) UL open type UL type 1 with option - see manual</p> <p>5: EAC, UL LISTED, TÜV NORD Safety Approved, CE, R-REI-Abb-ACS480-09A5-4, S/N: M192700002 (6)</p>		Input current is scaled by motor output current			Output	Input	Input (with 5% choke)	400/480 V	400/480 V	400/480 V	In 2.6/2.1	4.2/3.4	2.6/2.1	Ild 2.5/2.1	4/3.4	2.5/2.1	Ihd 1.8/1.6	2.9/2.6	1.8/1.6
Input current is scaled by motor output current																			
Output	Input	Input (with 5% choke)																	
400/480 V	400/480 V	400/480 V																	
In 2.6/2.1	4.2/3.4	2.6/2.1																	
Ild 2.5/2.1	4/3.4	2.5/2.1																	
Ihd 1.8/1.6	2.9/2.6	1.8/1.6																	
1	Type designation																		
2	Frame (size)																		
3	Degree of protection																		
4	Nominal ratings																		
5	Valid markings																		
6	S/N: Serial number of format MYYWWXXXX, where M: Manufacturer YY: Year of manufacture: 15, 16, 17, ... for 2015, 2016, 2017, ... WW: Week of manufacture: 01, 02, 03, ... for week 1, week 2, week 3, ... XXXX: Running item number that starts each week from 0001.																		

Model information label, IEC		Software information label, IEC	
<p>(1) ACS480-04-02A7-4</p> <p>(2) [Barcode]</p> <p>(3) S/N: M19270002</p>		<p>(1) ACS480-04-02A7-4</p> <p>(2) 3~400/480 V (Frame R1)</p> <p>(2) Pld: 0.75 kW (1 hp) Phd: 0.55 kW (0.75 hp)</p> <p>(3) S/N: M19270002</p> <p>(4) SW v2.05.0.7</p>	
1	Drive type	1	Type designation, input voltage and frame
2	Bar code	2	Power (light-duty and heavy duty)
3	Serial number	3	Serial number
		4	Drive software version

Type designation key

The type designation contains information on the specifications and configuration of the drive.

Sample type code: ACS480-04-12A7-4+XXXX

■ Basic code

Code	Description
ACS480	Product series
04	Construction. 04 = Module, IP20 (UL open type) When there are no options selected: cabinet optimized module, IP20 (UL open type), ACS-AP-S assistant control panel, I/O & EIA-485 module (RIIO-01), safe torque off, brake chopper, coated boards, quick installation and start-up guide. For the IEC drive types also EMC cat. C2 filter.
12A7	Size. See the ratings table in the technical data.
4	Input voltage. 4 = 3-phase 380...480 V AC

■ Option (plus) codes

Code	Description
Control panel and panel options	
J400	ACS-AP-S control panel
J404	ACS-BP-S basic control panel
J424	RDUM-01 blank cover with RJ45 connection, for remote mounting of the control panel
J425	ACS-AP-I industrial control panel
J429	ACS-AP-W control panel with Bluetooth
0J400	Without control panel
I/O	
L515	BIO-01 I/O extension module (front option, can be used with fieldbus).
L534	BAPO-01 external 24 V DC power extension module (side option).
L511	BREL-01 relay output extension module.
L540	RIIO-01 I/O & EIA-485 module (front option, as standard)
0L540	Base unit without RIIO-01 I/O & EIA-485 module
Fieldbus adapters	
K451	FDNA-01 DeviceNet
K454	FPBA-01 PROFIBUS DP
K457	FCAN-01 CANopen
K458	FSCA-01 Modbus/RTU
K469	FECA-01 EtherCAT
K470	FEPL-02 Ethernet POWERLINK
K475	FENA-21 2-port Ethernet (Ethernet/IP, Modbus/TCP, PROFINET)
K490	FEIP-21 Ethernet/IP
K491	FMBT-21 Modbus/TCP
K492	FPNO-21 PROFINET
Documentation	
Full set of printed manuals in the selected language. An English manual is included, if a translation is not available.	

Code	Description
R700	English
R701	German
R702	Italian
R703	Dutch
R704	Danish
R705	Swedish
R706	Finnish
R707	French
R708	Spanish
R709	Portuguese
R711	Russian
R712	Chinese
R713	Polish
R714	Turkish

4

Mechanical installation

Contents of this chapter

The chapter tells you how to examine the installation site, unpack, check the delivery and install the drive mechanically.



Installation alternatives

You can install the drive:

- With screws on to a wall
- With screws on to an assembly plate
- On to a DIN installation rail [Top Hat, W x H = 35 x 7.5 mm (1.4 x 0.3 in)].

Installation requirements:

- The drive has an IP20 (UL open type) protection classification for cabinet installation. UL type 1 kit is available as an option.
- Make sure that there is a minimum of 75 mm (2.95 in) of free space at the top and bottom of the drive (at the cooling air inlet and outlet).
- You can install several drives side by side. Note that side-mounted options require 20 mm (0.8 in) of space on the right side of the drive.
- You can install frames R1, R2, R3 and R4 tilted by up to 90 degrees from vertical to fully horizontal orientation.

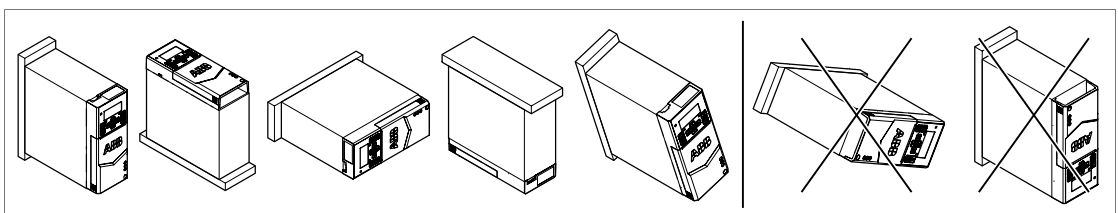

- Make sure that the cooling air exhaust at the top of the drive is not below the cooling air inlet at the bottom of the drive.
- Make sure that the hot exhaust air from a drive does not flow into the cooling inlet of other drives or equipment.
- Drives equipped with the optional UL type 1 kits: If you install the drives side-by-side, make sure that their air outlets do not face each other.

Examining the installation site

Examine the installation site:

- The installation site is sufficiently ventilated or cooled to remove heat from the drive. See the technical data.
- The ambient conditions of the drive meet the specifications. See the technical data.
- The wall behind the unit and the material above and below the unit is of non-flammable material.
- The installation surface is as close to vertical as possible and strong enough to support the drive.
- There is enough free space around the drive to enable cooling, maintenance, and operation. See the free space specifications for the drive.
- Make sure that there are no sources of strong magnetic fields such as high-current single-core conductors or contactor coils near the drive. A strong magnetic field can cause interference or inaccuracy in the operation of the drive.



Required tools

To install the drive mechanically, you need the following tools:

- a drill and suitable drill bits
- a screwdriver or wrench with a set of suitable bits (PH0–3, PZ0–3, T15–40, S4–7) (For motor cable terminals, the recommended shaft length is 150 mm (5.9 in))
- a tape measure and spirit level
- personal protective equipment.

Unpacking the delivery

Make sure that all of the items are present and that there are no signs of damage.

Standard drive package contents:

- Drive
 - Assistant control panel (not installed)
 - I/O & EIA-485 module RIIO-01 (not installed)
 - Mounting template (for R3 and larger drives)
 - Installation accessories (cable clamps, etc.)
 - Options, if ordered with a plus code. Note that if a fieldbus adapter is ordered, it replaces the I/O & EIA-485 module RIIO-01 of the standard delivery.
 - Multilingual warning sticker sheet (residual voltage warning)
 - Safety instructions
 - Quick installation and start-up guide
 - Hardware and firmware manuals, if ordered with a plus code.
-

Installing the drive

■ To install the drive with screws

1. Mark the surface for the mounting holes. Use the mounting templates for R3 and R4 frames. For other frames, see the dimension drawings.
2. Drill the holes for the mounting screws.
3. Insert anchors or plugs into the holes (if necessary) and install the screws.

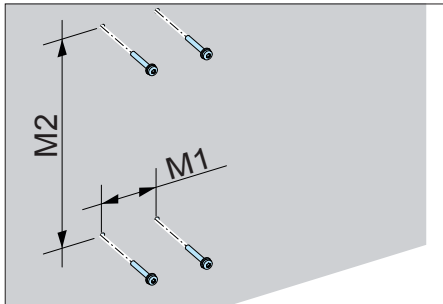

4. Position the drive onto the mounting screws.
5. Tighten the mounting screws.

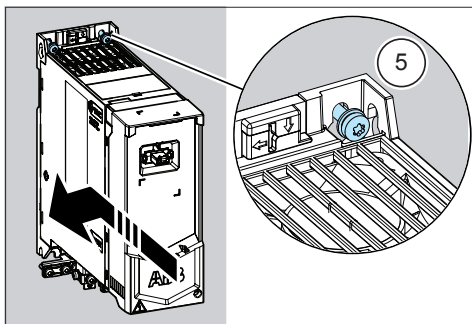

■ To install the drive to a DIN installation rail

Use the installation rail type Top Hat, W x H = 35 x 7.5 mm (1.4 x 0.3 in).

1. Move the locking part to the left.

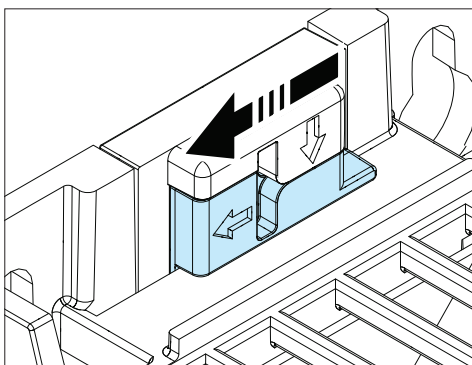

38 Mechanical installation

2. Push and hold the locking button down.

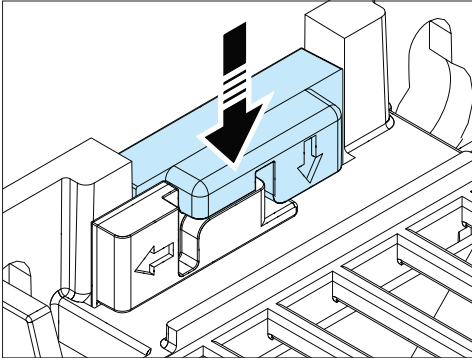

3. Put the top tabs of the drive onto the top edge of the DIN installation rail.
4. Put the drive against the bottom edge of the DIN installation rail.
5. Release the locking button.
6. Move the locking part to the right.
7. Make sure that the drive is correctly installed.

To remove the drive, use a flat-head screwdriver to open the locking part.



5

Guidelines for planning the electrical installation

Contents of this chapter

This chapter contains guidelines for planning the electrical installation of the drive.

Limitation of liability

The installation must always be designed and made according to applicable local laws and regulations. ABB does not assume any liability whatsoever for any installation which breaches the local laws and/or other regulations. Furthermore, if the recommendations given by ABB are not followed, the drive may experience problems that the warranty does not cover.

Selecting the main supply disconnecting device

You must equip the drive with a main supply disconnecting device which meets the local safety regulations. You must be able to lock the disconnecting device to the open position for installation and maintenance work.

■ European Union

To meet the European Union Directives, according to standard EN 60204-1, Safety of Machinery, the disconnecting device must be one of the following types:

- switch-disconnector, with or without fuses, in accordance with IEC 60947-3, utilization category AC-23B or DC-23B
 - disconnector that has an auxiliary contact that in all cases causes switching devices to break the load circuit before the opening of the main contacts of the disconnector (EN 60947-3)
 - a circuit-breaker suitable for isolation in accordance with IEC 60947-2.
-

■ North America

Installations must meet the requirements of UL (UL 508C) and/or CSA C22.2 No. 14 and be compliant with NFPA 70 (NEC) and/or Canadian Electrical Code (CE) along with state and local codes for your location and application. (NFPA 70 (NEC) = National Fire Protection Association 70 (National Electric Code).

■ Other regions

The disconnecting device must conform to the applicable local safety regulations.

Selecting the main contactor

You can equip the drive with a main contactor.

Obey these guidelines when you select a customer-defined main contactor:

- Dimension the contactor according to the nominal voltage and current of the drive. Also consider the environmental conditions such as ambient temperature.
- Select contactor with utilization category AC-1 (number of operations under load) according to IEC 60947-4, *Low-voltage switch gear and control gear*.
- Consider the application life time requirements.

Checking the compatibility of the motor and drive

Use asynchronous AC induction motor, permanent magnet synchronous motor or ABB synchronous reluctance motor (SynRM motors) with the drive. Several induction motors can be connected to the drive at a time.

Make sure that the motor and the drive are compatible according to the rating table in the technical data.

Selecting the power cables

■ General guidelines

Select the input power and motor cables according to local regulations.

- **Current:** Select a cable capable of carrying the drive (or motor) nominal current.
- **Temperature:** For an IEC installation, select a cable rated for at least 70 °C (158 °F) maximum permissible temperature of conductor in continuous use. For North America, select a cable rated for at least 75 °C (167 °F).
- **Voltage:** 600 V AC cable is accepted for up to 500 V AC. 750 V AC cable is accepted for up to 600 V AC. 1000 V AC cable is accepted for up to 690 V AC.

To comply with the EMC requirements of the CE mark, use one of the preferred cable types. See [Preferred power cable types \(page 41\)](#).

Symmetrical shielded cable reduces electromagnetic emission of the whole drive system as well as the stress on motor insulation, bearing currents and wear.

Metal conduit reduces electromagnetic emission of the whole drive system.

The protective conductor must always have an adequate conductivity.

Unless local wiring regulations state otherwise, the cross-sectional area of the protective conductor must agree with the conditions that require automatic disconnection of the supply required in 411.3.2. of IEC 60364-4-41:2005 and be capable of withstanding the prospective

fault current during the disconnection time of the protective device. The cross-sectional area of the protective conductor can either be selected from the table below or calculated according to 543.1 of IEC 60364-5-54.

This table shows the minimum cross-sectional area of the protective conductor related to the phase conductor size according to IEC 61800-5-1 when the phase conductor and the protective conductor are made of the same metal. If this is not so, the cross-sectional area of the protective earthing conductor shall be determined in a manner which produces a conductance equivalent to that which results from the application of this table.

Cross-sectional area of the phase conductors S (mm ²)	Minimum cross-sectional area of the corresponding protective conductor S _p (mm ²)
S ≤ 16	S ^{1), 2)}
16 < S ≤ 35	16
35 < S	S/2

1) Drive safety standard IEC/EN 61800-5-1:

- use a protective earth conductor with a cross-section of at least 10 mm² (8 AWG) Cu or 16 mm² (6 AWG) Al, or
- use a second protective earth conductor of the same cross-sectional area as the original protective earthing conductor, or
- use a device which automatically disconnects the supply if the protective earth conductor breaks.

2) Drive safety standard IEC/EN 61800-5-1: If the protective earth conductor is separate (ie, it does not form part of the input power cable or the input power cable enclosure), the cross section must be at least:

- 2.5 mm² (14 AWG) when the conductor is mechanically protected, or
- 4 mm² (12 AWG) when the conductor is not mechanically protected.

■ Typical power cable sizes

See the technical data.

■ Power cable types

Preferred power cable types

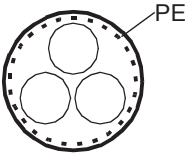
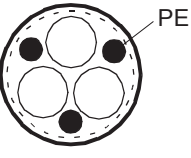

This section presents the preferred cable types. Make sure that the selected cable type also complies with local/state/country electrical codes.

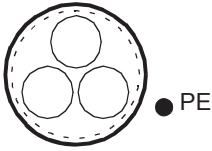
Cable type	Use as input power cabling	Use as motor cabling
 <p>Symmetrical shielded (or armored) cable with three phase conductors and concentric PE conductor as shield (or armor)</p>	Yes	Yes
 <p>Symmetrical shielded (or armored) cable with three phase conductors and symmetrically constructed PE conductor and a shield (or armor)</p>	Yes	Yes

Cable type	Use as input power cabling	Use as motor cabling
 <p>Symmetrical shielded (or armored) cable with three phase conductors and a shield (or armor), and separate PE conductor/cable¹⁾</p>	Yes	Yes

¹⁾ A separate PE conductor is required if the conductivity of the shield (or armor) is not sufficient for the PE use.

Alternate power cable types

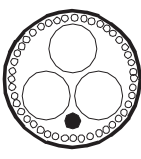
Cable type	Use as input power cabling	Use as motor cabling
 <p>Four-conductor cabling in PVC conduit or jacket (three phase conductors and PE)</p>	Yes with phase conductor smaller than 10 mm ² (8 AWG) Cu.	Yes with phase conductor smaller than 10 mm ² (8 AWG) Cu, or motors up to 30 kW (40 hp). Note: Shielded or armored cable, or cabling in metal conduit is always recommended to minimize radio frequency interference.
 <p>Four-conductor cabling in metal conduit (three phase conductors and PE), eg, EMT, or four-conductor armored cable</p>	Yes	Yes with phase conductor smaller than 10 mm ² (8 AWG) Cu, or motors up to 30 kW (40 hp)
 <p>Well-shielded (Al/Cu shield or armor) four-conductor cable (three phase conductors and a PE)</p>	Yes	Yes with motors up to 100 kW (135 hp). A potential equalization between the frames of motor and driven equipment is required.

Not allowed power cable types

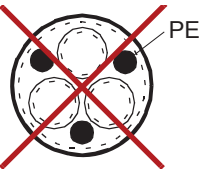
Cable type	Use as input power cabling	Use as motor cabling
 <p>Symmetrical shielded cable with individual shields for each phase conductor</p>	No	No

■ **Additional guidelines, North America**

ABB recommends the use of conduit for power wiring to the drive and between the drive and the motor(s). Due to the variety of application needs, metallic and non-metallic conduit can be used. ABB prefers the use of metallic conduit.

The following table shows examples of various materials and methods for wiring the drive in the intended application. See NEC 70 along with state and local codes for the appropriate materials for your application.

In all applications, ABB prefers the use of symmetrical shielded VFD cable between drive and motor(s).

Wiring method	Notes
Conduit - Metallic ^{1) 2)}	
Electrical metallic tubing: Type EMT	Prefer symmetrical shielded VFD cable.
Rigid metal conduit: Type RMC	Use separate conduit run for each motor.
Liquid-tight flexible metal electrical conduit: Type LFMC	Do not run input power wiring and motor wiring in the same conduit.
Conduit - Non-metallic ^{2) 3)}	
Liquid-tight flexible non-metallic conduit: Type LFNC	Prefer symmetrical shielded VFD cable. Use separate conduit run for each motor. Do not run input power wiring and motor wiring in the same conduit.
Wireways ²⁾	
Metallic	Prefer symmetrical shielded VFD cable. Separate motor wiring from input power wiring and other low voltage wiring. Do not run outputs of multiple drives parallel. Bundle each cable (wiring) together and use separators where possible.
Free air ²⁾	
Enclosures, air handlers, etc.	Prefer symmetrical shielded VFD cable. Allowed internally in enclosures when in accordance with UL.

1) Metallic conduit may be used as an additional ground path, provided this path is a solid path capable of handling ground currents.

2) See NFPA NEC 70, UL, and local codes for your application.

3) Non-metallic conduit use underground is allowed; however, these installations inherently have an increased chance for nuisance problems due to the potential for water/moisture in the conduit. Water/moisture in the conduit increases the likelihood of VFD faults or warnings. Proper installation is required to make sure there is no intrusion of water/moisture.

Metal conduit

Couple separate parts of a metal conduit together: bridge the joints with a ground conductor bonded to the conduit on each side of the joint. Also bond the conduits to the drive enclosure and motor frame. Use separate conduits for input power, motor, brake resistor, and control wiring. Do not run motor wiring from more than one drive in the same conduit.

■ **Power cable shield**

If the cable shield is used as the sole protective earth (PE) conductor, make sure that its conductivity agrees with the PE conductor requirements.

To effectively suppress radiated and conducted radio-frequency emissions, the cable shield conductivity must be at least 1/10 of the phase conductor conductivity. The requirements

are easily met with a copper or aluminum shield. The minimum requirement of the motor cable shield of the drive is shown below. It consists of a concentric layer of copper wires with an open helix of copper tape or copper wire. The better and tighter the shield, the lower the emission level and bearing currents.

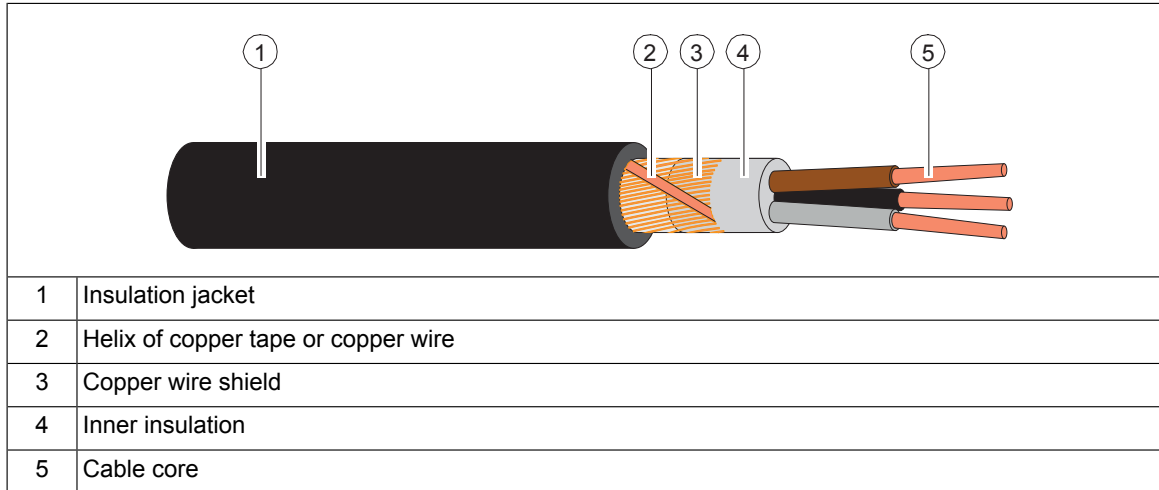

Selecting the control cables

■ Shielding

Only use shielded control cables.

Use a double-shielded twisted pair cable for analog signals. This type of cable is recommended for the pulse encoder signals also. Employ one individually shielded pair for each signal. Do not use common return for different analog signals.

A double-shielded cable (a) is the best alternative for low-voltage digital signals, but single-shielded (b) twisted pair cable is also acceptable.

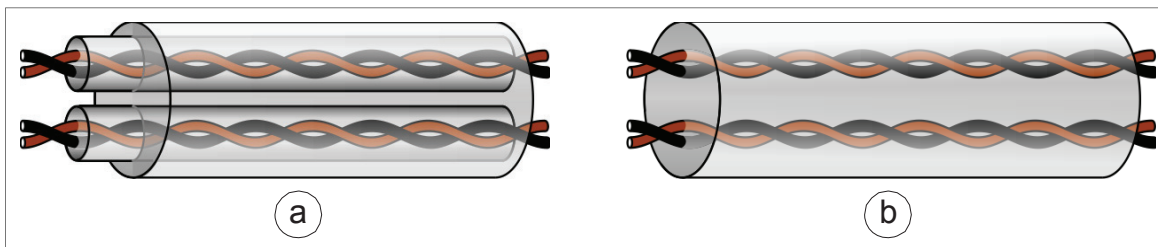

■ Signals in separate cables

Run analog and digital signals in separate, shielded cables. Do not mix 24 V DC and 115/230 V AC signals in the same cable.

■ Signals that can be run in the same cable

If their voltage does not exceed 48 V, relay-controlled signals can be run in the same cables as digital input signals. The relay-controlled signals should be run as twisted pairs.

■ Relay cable type

The cable type with braided metallic shield (for example ÖLFLEX by LAPPKABEL, Germany) has been tested and approved by ABB.

■ **Control panel to drive cable**

Use EIA-485 with male RJ-45 connector, cable type Cat 5e or better. The maximum permitted length of the cable is 100 m (328 ft).

Routing the cables

■ **General guidelines – IEC**

- Route the motor cable away from other cables. Motor cables of several drives can be run in parallel installed next to each other.
- Install the motor cable, input power cable and control cables on separate trays.
- Avoid long parallel runs of motor cables with other cables.
- Where control cables must cross power cables, make sure they are arranged at an angle as near to 90 degrees as possible.
- Do not run extra cables through the drive.
- Make sure that the cable trays have good electrical bonding to each other and to the grounding electrodes. Aluminum tray systems can be used to improve local equalizing of potential.

This figure illustrates the cable routing guidelines with an example drive.

Note: When motor cable is symmetrical and shielded and it has short parallel runs with other cables (< 1.5 m / 5 ft), distances between the motor cable and other cables can be reduced by half.

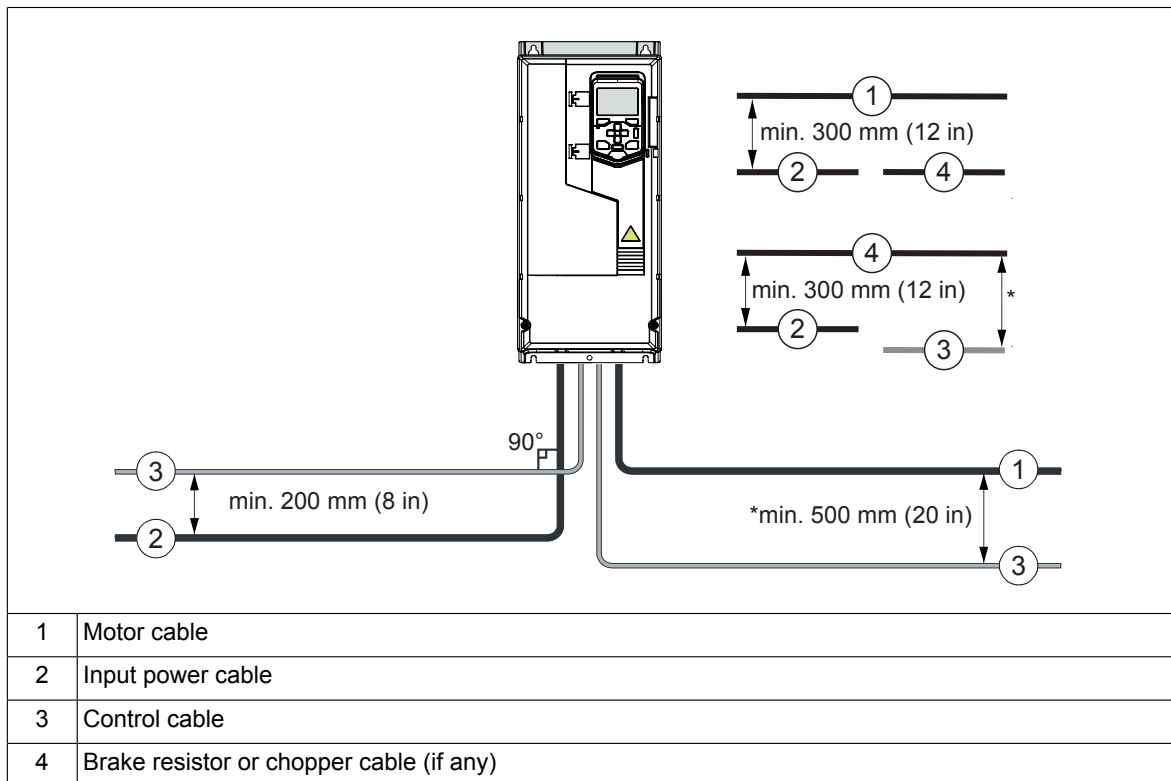

■ **General guidelines – North America**

Make sure that the installation is in accordance with national and local codes. Obey these general guidelines:

46 Guidelines for planning the electrical installation

- Use separate conduits for the input power, motor, brake resistor (optional), and control cabling.
- Use separate conduit for each motor cabling.

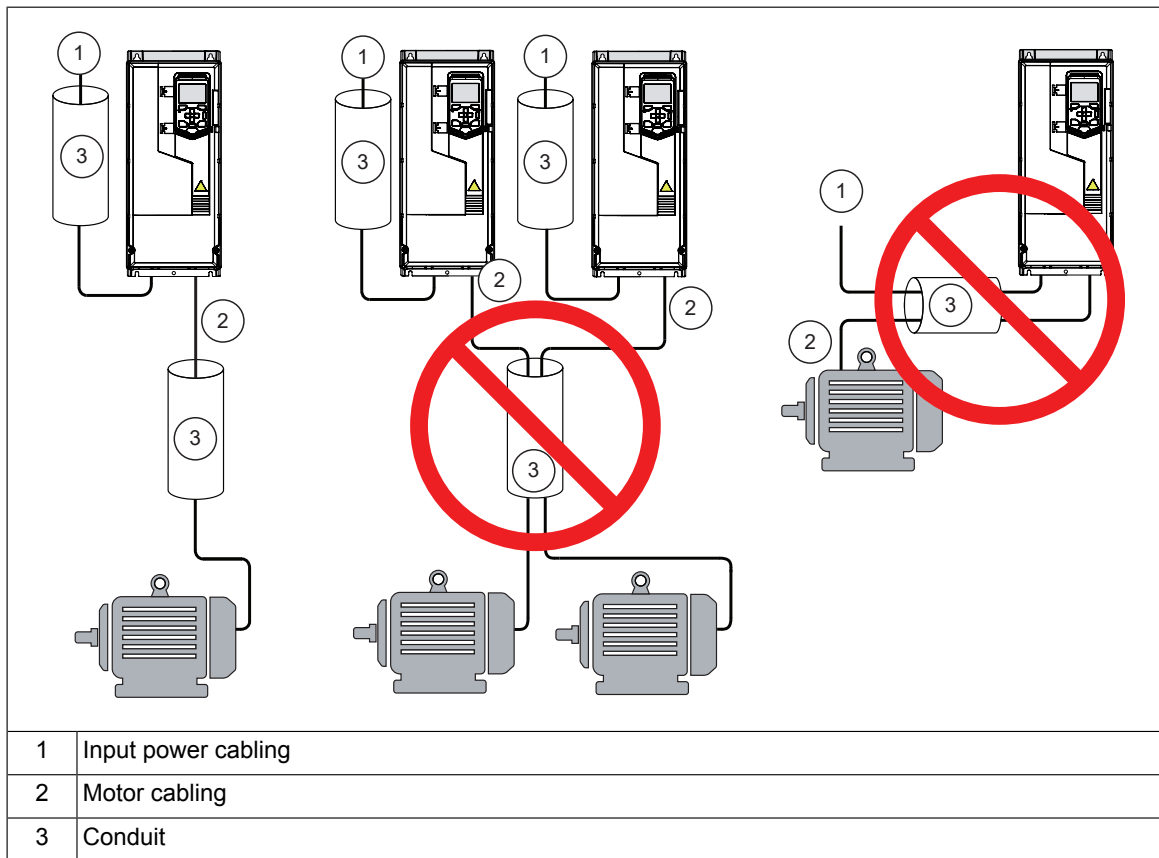

■ Continuous motor cable shield/conduit or enclosure for equipment on the motor cable

To minimize the emission level when safety switches, contactors, connection boxes or similar equipment are installed on the motor cable between the drive and the motor:

- Install the equipment in a metal enclosure.
- Use either a symmetrical shielded cable, or install the cabling in a metal conduit.
- Make sure that there is a good and continuous galvanic connection in the shield/conduit between drive and motor.
- Connect the shield/conduit to the protective ground terminal of the drive and the motor.

■ Separate control cable ducts

Put 24 V DC and 230 V AC (120 V AC) control cables in separate ducts, unless the 24 V DC cable is insulated for 230 V AC (120 V AC) or insulated with an insulation sleeving for 230 V AC (120 V AC).

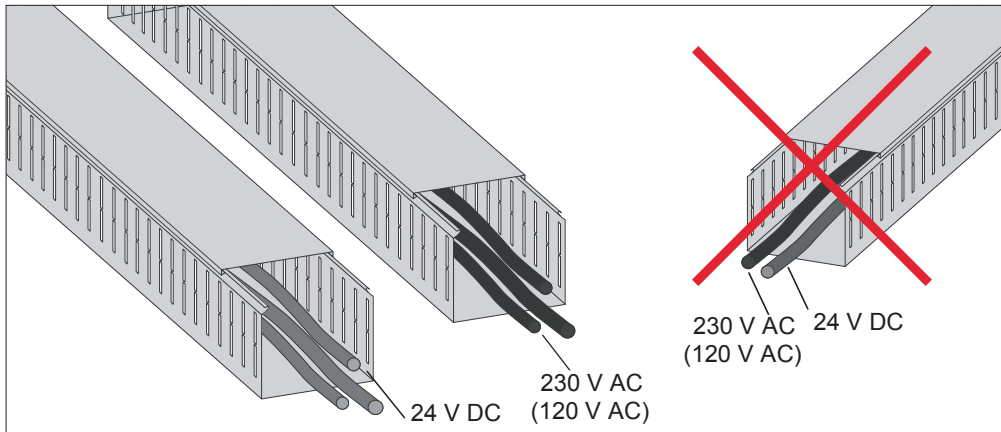

Implementing short-circuit and thermal overload protection

■ Protecting the drive and input power cable in short-circuits

Use the fuses specified in the technical data. Make sure that the electric power supply network meets the specification (minimum allowed short-circuit current for the fuses).

The fuses restrict drive damage and prevent damage to adjoining equipment in case of a short-circuit inside the drive. When located at the distribution board, the fuses also protect the input power cable against short circuits.

See the technical data for alternative short-circuit protections.

■ Protecting the motor and motor cable in short-circuits

The drive protects the motor cable and motor in a short-circuit situation when the motor cable is sized according to the nominal current of the drive. No additional protection devices are needed.

■ Protecting the drive, and the input power and motor cables against thermal overload

If the cables have the correct size for the nominal current, the drive protects itself and the input and motor cables against thermal overload. No additional thermal protection devices are needed.



WARNING!

If the drive is connected to multiple motors, use a separate motor thermal overload device for protecting each motor cable and motor against overload. The drive overload protection is for the sum of the total motor load. It may not trip due to an overload in one motor.

■ Protecting the motor against thermal overload

According to regulations, the motor must be protected against thermal overload and the current must be switched off when overload is detected. The drive includes a motor thermal

protection function that protects the motor and switches off the current when necessary. Depending on a drive parameter value, the function either monitors a calculated temperature value (based on a motor thermal model) or an actual temperature indication given by motor temperature sensors.

The motor thermal protection model supports thermal memory retention and speed sensitivity. The user can tune the thermal model further by feeding in additional motor and load data.

The most common temperature sensors are:

- motor sizes IEC180...225: thermal switch, for example Klixon
- motor sizes IEC200...250 and larger: PTC or Pt100.

See the firmware manual for more information on the motor thermal protection function.

■ Protecting the motor against overload without thermal model or temperature sensors

Motor overload protection protects the motor against overload without using motor thermal model or temperature sensors.

Motor overload protection is required and specified by multiple standards including the US National Electric Code (NEC), UL 508C and the common UL/IEC 61800-5-1 standard in conjunction with IEC 60947-4-1. The standards allow for motor overload protection without external temperature sensors.

The protection feature allows the user to specify the class of operation in the same manner as the overload relays are specified in standards IEC 60947-4-1 and NEMA ICS 2.

The motor overload protection supports thermal memory retention and speed sensitivity.

For more information, see drive firmware manual.

Implementing a motor temperature sensor connection



WARNING!

IEC 60664 and IEC 61800-5-1 require double or reinforced insulation between live parts and accessible parts when:

- the accessible parts are not conductive, or
- the accessible parts are conductive, but not connected to the protective earth.

Obey this requirement when you plan the connection of the motor temperature sensor to the drive.

You have these implementation alternatives:

1. If there is double or reinforced insulation between the sensor and the live parts of the motor: You can connect the sensor directly to the analog/digital input(s) of the drive. See the control cable connection instructions.
2. If there is basic insulation between the sensor and the live parts of the motor: You can connect the sensor to the analog/digital input(s) of the drive. All other circuits connected to the digital and analog inputs (typically extra-low voltage circuits) must be:
 - protected against contact, and
 - insulated with basic insulation from other low-voltage circuits. The insulation must be rated for the same voltage level as the drive main circuit.

Note: Extra-low voltage circuits (for example, 24 V DC) typically do not meet these requirements.

As an alternative, you can connect the sensor with basic insulation to the analog/digital input(s) of the drive, if you do not connect any other external control circuits to the drive digital and analog inputs.

3. You can connect a sensor to a digital input of the drive via an external relay. The sensor and the relay must form a double or reinforced insulation between the motor live parts and the digital input of the drive.

Protecting the drive against ground faults

The drive is equipped with an internal ground fault protective function to protect the unit against ground faults in the motor and motor cable. This function is not a personnel safety or a fire protection feature. See the firmware manual for more information.

■ Residual current device compatibility

The drive is suitable to be used with residual current devices of Type B.

Note: As standard, the drive contains capacitors connected between the main circuit and the frame. These capacitors and long motor cables increase the ground leakage current and may cause nuisance faults in residual current devices.

Implementing the Emergency stop function

For safety reasons, install the emergency stop devices at each operator control station and at other operating stations where emergency stop may be needed. Design the emergency stop according to the applicable standards.

You can use the Safe torque off function of the drive to implement the Emergency stop function.

Note: Pressing the stop (off) key on the control panel of the drive does not generate an emergency stop of the motor or separate the drive from dangerous potential.

Implementing the Safe torque off function

See chapter [The Safe torque off function \(page 147\)](#).

Using a safety switch between the drive and the motor

ABB recommends to install a safety switch between the permanent magnet motor and the drive output. The switch is needed to isolate the motor during any maintenance work on the drive.

Implementing the control of a contactor between drive and motor

The control of the output contactor depends on how you use the drive, that is, which motor control mode and which motor stop mode you select.

When you select the vector motor control mode and the motor ramp stop mode, use this operation sequence to open the contactor:

1. Give a stop command to the drive.
 2. Wait until the drive decelerates the motor to zero speed.
 3. Open the contactor.
-



WARNING!

If vector motor control mode is in use, do not open the output contactor while the drive controls the motor. The motor control operates faster than the contactor, and tries to maintain the load current. This can cause damage to the contactor.

When you select the vector motor control mode and the motor coast stop mode, you can open the contactor immediately after the drive has received the stop command. This is the case also if you use the scalar motor control mode.

Protecting the contacts of relay outputs

Inductive loads (relays, contactors, motors) cause voltage transients when switched off. It is highly recommended that inductive loads are equipped with noise attenuating circuits (varistors, RC filters [AC] or diodes [DC]) in order to minimize the EMC emission at switch-off. If not suppressed, the disturbances may connect capacitively or inductively to other conductors in the control cable and form a risk of malfunction in other parts of the system.

Install the protective component as close to the inductive load as possible. Do not install protective components at the relay outputs.

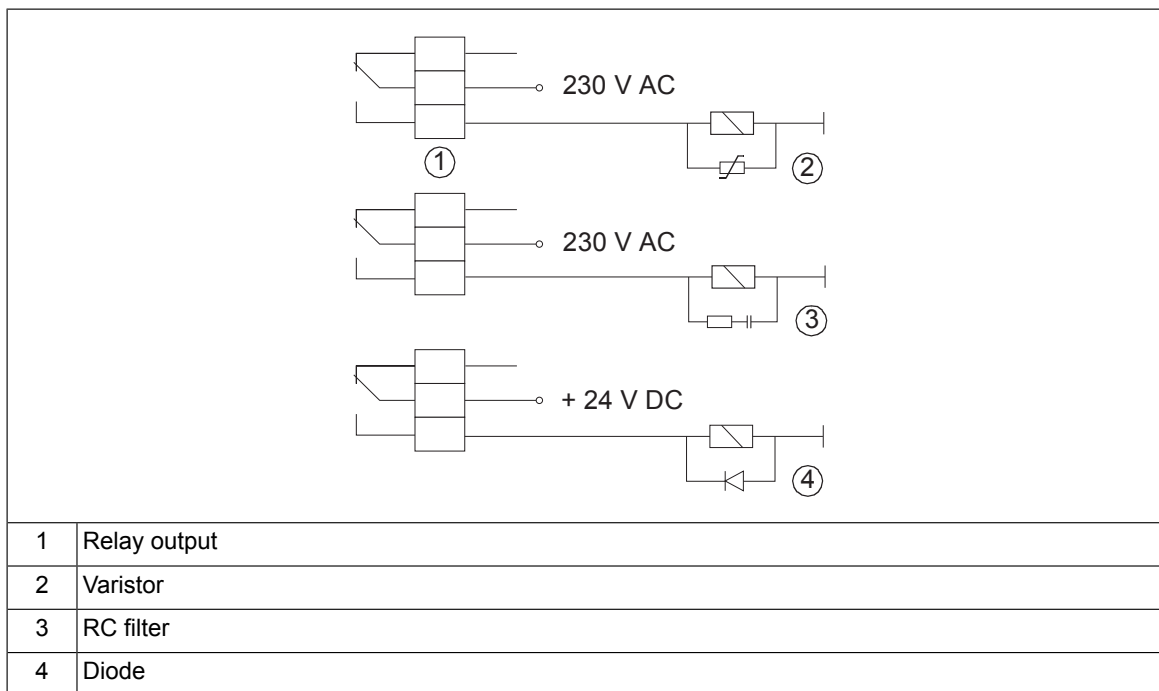

6

Electrical installation – IEC

Contents of this chapter

This chapter describes:

- how to measure the insulation
- how to do an earthing system compatibility check, and change the EMC filter or ground-to-phase varistor connection (if necessary)
- how to connect the power and control cabling, install optional modules and connect a PC.

Warnings



WARNING!

Obey the safety instructions of the drive. If you ignore them, injury or death, or damage to the equipment can occur.

If you are not a qualified electrical professional, do not do installation or maintenance work.

Required tools

To do the electrical installation, you need the following tools:

- wire stripper
 - screwdriver or wrench with a set of suitable bits
 - short flat head screwdriver for the I/O terminals
 - multimeter and voltage detector
 - personal protective equipment
-

Measuring the insulation

Measuring the insulation is typically not required in North America.

■ Measuring the insulation of the drive system



WARNING!

Do not do any voltage withstand or insulation resistance tests on any part of the drive as testing can damage the drive. Every drive has been tested for insulation between the main circuit and the chassis at the factory. Also, there are voltage-limiting circuits inside the drive which cut down the testing voltage automatically.

■ Measuring the insulation of the input cable

Before you connect the input power cable to the drive, measure its insulation according to local regulations.

■ Measuring the insulation of the motor and motor cable



WARNING!

Obey the safety instructions of the drive. If you ignore them, injury or death, or damage to the equipment can occur.

If you are not a qualified electrical professional, do not do installation or maintenance work.

1. Stop the drive and do the steps in section [Electrical safety precautions \(page 14\)](#) before you start the work.
2. Make sure that the motor cable is disconnected from the drive output terminals.
3. Measure the insulation resistance between each phase conductor and the protective earth conductor. Use a measuring voltage of 1000 V DC. The insulation resistance of an ABB motor must exceed 100 Mohm (reference value at 25 °C [77 °F]). For the insulation resistance of other motors, consult the manufacturer's instructions.

Note: Moisture inside the motor casing reduces the insulation resistance. If moisture is suspected, dry the motor and repeat the measurement.

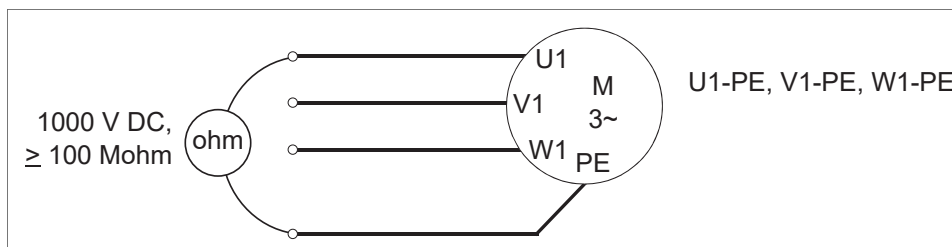

■ Measuring the insulation of brake resistor and resistor cable



WARNING!

Obey the safety instructions of the drive. If you ignore them, injury or death, or damage to the equipment can occur.

If you are not a qualified electrical professional, do not do installation or maintenance work.

1. Stop the drive and do the steps in section [Electrical safety precautions \(page 14\)](#) before you start the work.
2. Make sure that the resistor cable is connected to the resistor and disconnected from the drive output terminals.
3. At the drive end, connect the R+ and R- conductors of the resistor cable together. Measure the insulation resistance between the conductors and the PE conductor with a measuring voltage of 1000 V DC. The insulation resistance must be higher than 1 Mohm.

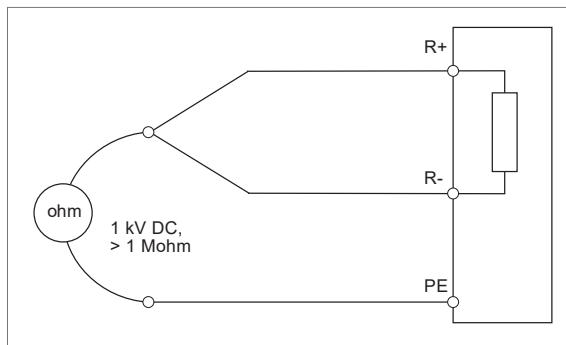

Earthing system compatibility check – IEC

This section is valid for the IEC drive types. For the UL(NEC) drive types, see [Earthing system compatibility check – North America \(page 71\)](#).

■ EMC filter compatibility

The drive has an internal EMC filter as standard. You can install the drive to a symmetrically grounded TN-S system. If you install the drive to another system, you may need to disconnect the EMC filter. See [When to disconnect EMC filter or ground-to-phase varistor \(page 53\)](#).

Note: If you disconnect the EMC filter, the electromagnetic compatibility of the drive decreases.

■ Ground-to-phase varistor compatibility

A drive with the ground-to-phase varistor connected can be installed to a symmetrically grounded TN-S system. If you install the drive to another system, you may need to disconnect the varistor. See [When to disconnect EMC filter or ground-to-phase varistor](#).

■ When to disconnect EMC filter or ground-to-phase varistor

The table below shows different earthing systems, and when you need to disconnect the EMC filter (metal EMC screw) or ground-to-phase varistor (metal VAR screw).



WARNING!

Remove the metal EMC screw in systems other than the symmetrically grounded TN-S systems. If you do not, it can cause danger or damage to the drive.



WARNING!

Remove the metal VAR screw in IT systems. If you do not, it can cause danger or damage to the drive.

Screw label	Screw material	Earthing systems and the need to remove EMC screw or VAR screw		
		Symmetrically grounded TN-S systems, i.e., center grounded-wye (A)	Corner-grounded delta (B1), midpoint-grounded delta (B2) and TT (D) systems	IT systems (ungrounded or high-resistance grounded) (C)
EMC	Metal	Do not remove	Remove	Remove
VAR	Frames R1, R3, R4: Metal	Do not remove	Do not remove	Remove
	Frame R2: Plastic	Do not remove	Do not remove	Do not remove

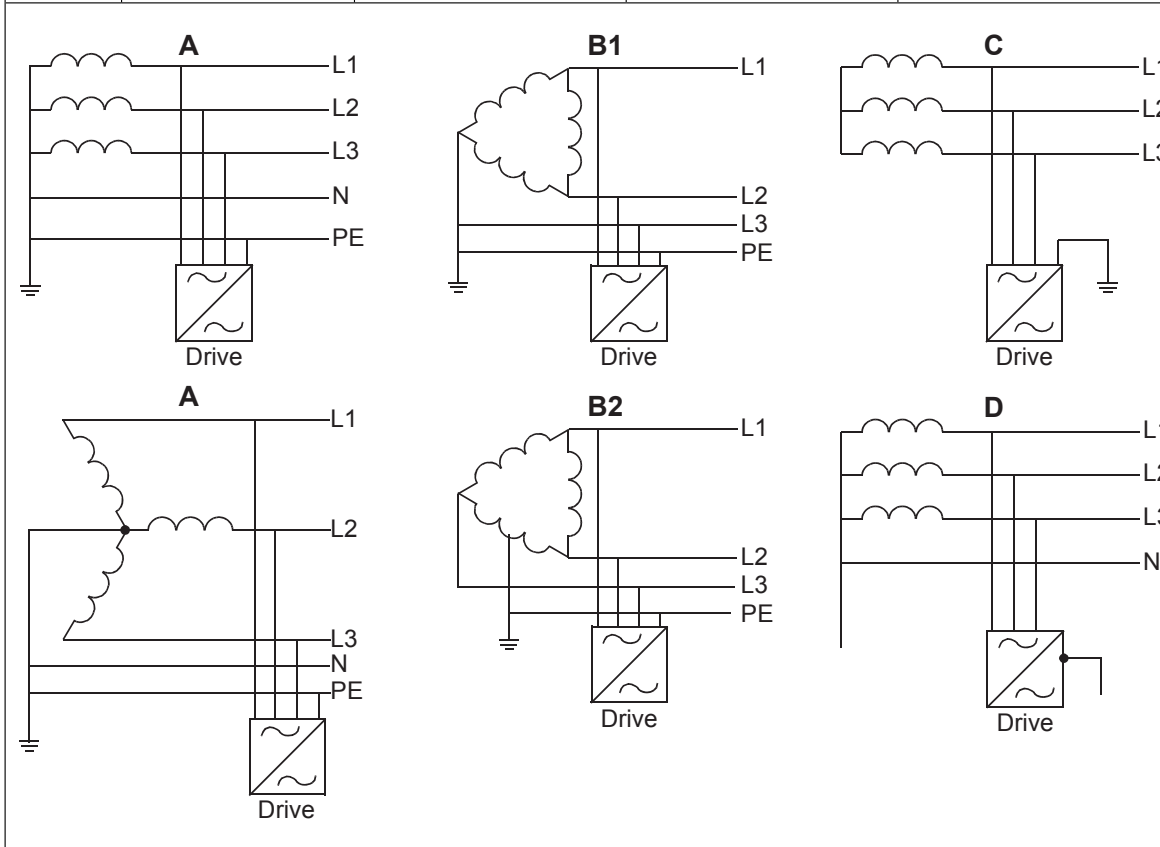

■ **Disconnecting the EMC filter or ground-to-phase varistor**

Before you proceed, see [When to disconnect EMC filter or ground-to-phase varistor \(page 53\)](#). Obey the guidelines.

1. Stop the drive and disconnect it from the power line.
2. Wait 5 minutes to let the intermediate circuit capacitors discharge.
3. To disconnect the EMC filter, remove the metal EMC screw.
4. To disconnect the varistor, remove the metal VAR screw.

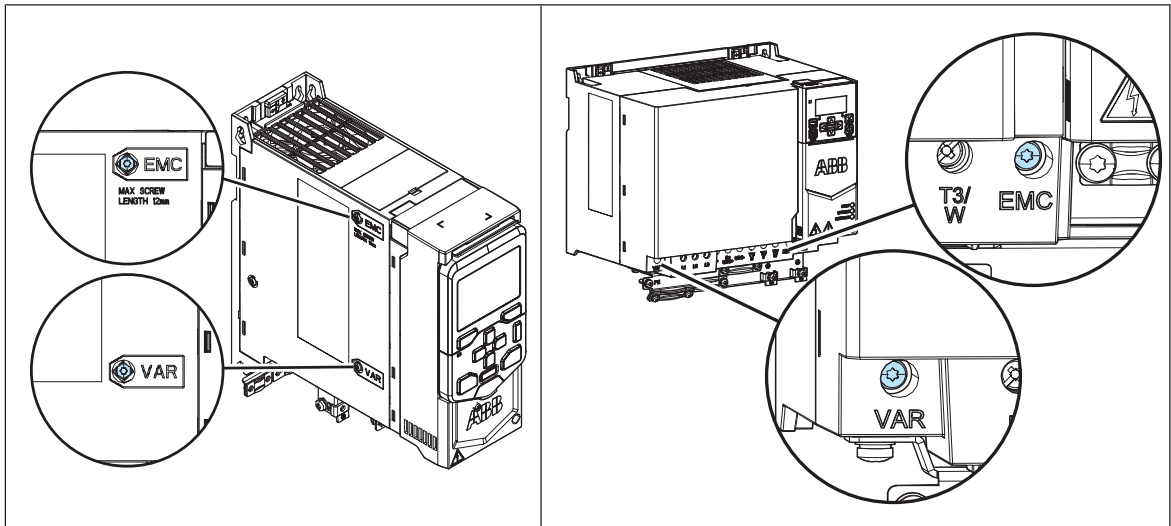

■ Identifying the earthing system of the electrical power network



WARNING!

Only a qualified electrical professional may do the work instructed in this section. Depending on the installation site, the work may even be categorized as live working. Proceed only if you are an electrical professional certified for the work. Obey the local regulations. If you ignore them, injury or death can occur.

To identify the earthing system, find out the supply transformer connection. If that is not possible, measure these voltages at the distribution board, and use the table below to define the earthing system type.

1. input voltage line to line (U_{L-L})
2. input voltage line 1 to ground (U_{L1-G})
3. input voltage line 2 to ground (U_{L2-G})
4. input voltage line 3 to ground (U_{L3-G}).

The table below shows the line-to-ground voltages in relation to the line-to-line voltage for each earthing system.

U_{L-L}	U_{L1-G}	U_{L2-G}	U_{L3-G}	Electrical power system type
X	$0.58 \cdot X$	$0.58 \cdot X$	$0.58 \cdot X$	Symmetrically grounded TN system (TN-S system)
X	$1.0 \cdot X$	$1.0 \cdot X$	0	Corner-grounded delta system (nonsymmetrical)
X	$0.866 \cdot X$	$0.5 \cdot X$	$0.5 \cdot X$	Midpoint-grounded delta system (nonsymmetrical)
X	Varying level versus time	Varying level versus time	Varying level versus time	IT systems (ungrounded or high-resistance-grounded [>30 ohms]) nonsymmetrical
X	Varying level versus time	Varying level versus time	Varying level versus time	TT system (the protective earth connection for the consumer is provided by a local earth electrode, and there is another independently installed at the generator)



Connecting the power cables – IEC (shielded cables)

Use a symmetrical shielded power cable (VFD cable) as the motor cable.

■ Connection diagram

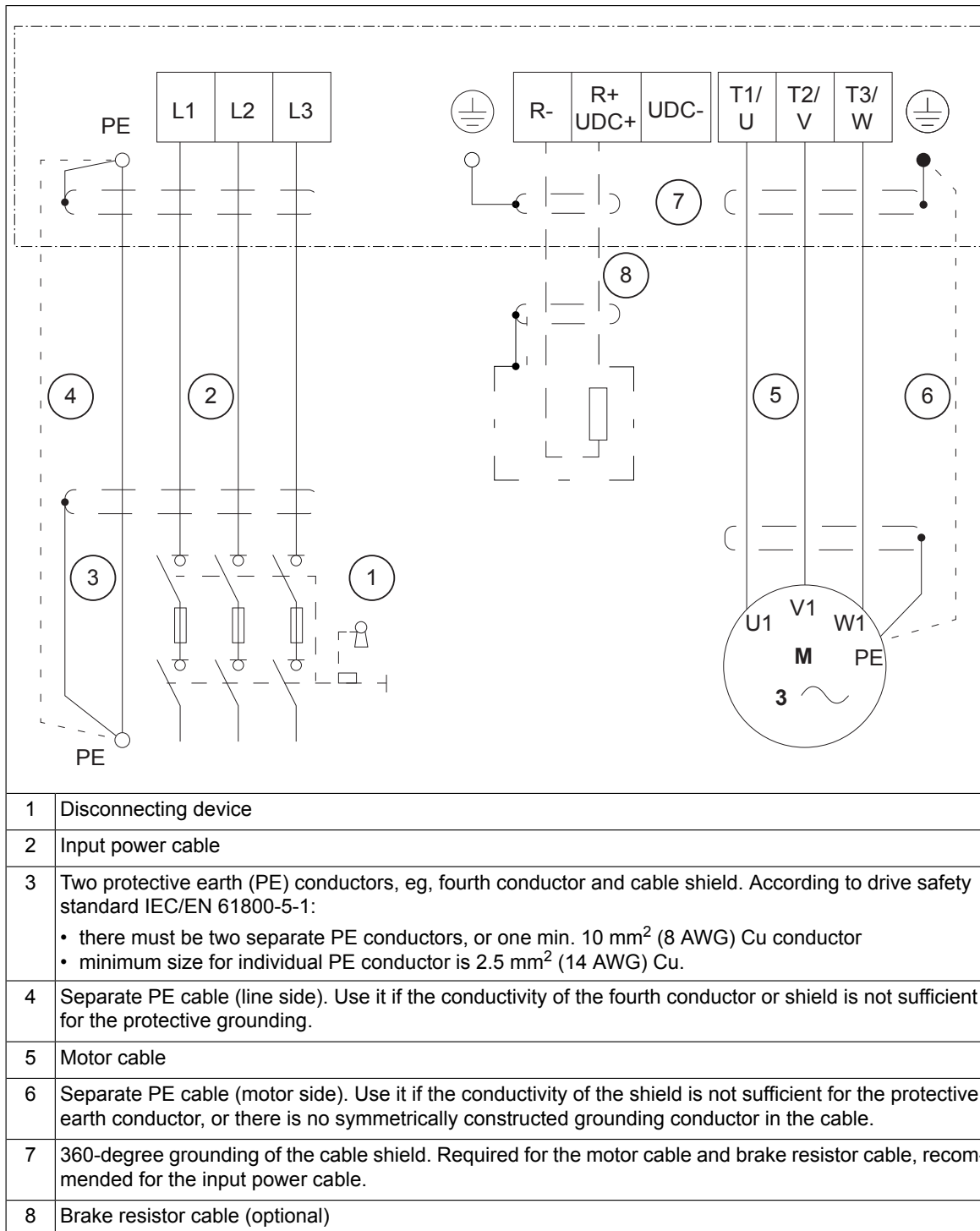

■ Connection procedure



WARNING!

Obey the safety instructions of the drive. If you ignore them, injury or death, or damage to the equipment can occur.

If you are not a qualified electrical professional, do not do installation or maintenance work.

1. Stop the drive and do the steps in section *Electrical safety precautions (page 14)* before you start the work.
2. Open the locking screw of the front cover and lift the front cover up.

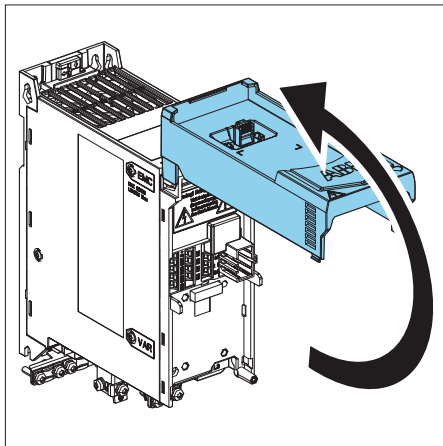

3. Strip the motor cable.
4. Ground the motor cable shield under the grounding clamp (360-degree grounding).

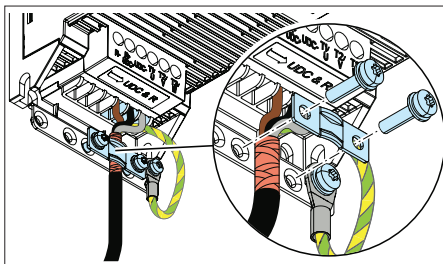

5. Twist the motor cable shield into a bundle, mark it with yellow-green insulation tape, fit a cable lug, and connect it to the grounding terminal.
6. Connect the phase conductors of the motor cable to the T1/U, T2/V and T3/W motor terminals.
7. If you use a brake resistor, connect the brake resistor cable to the R- and UDC+ terminals. Use shielded cable and ground the shield under the grounding clamp (360-degree grounding).
8. Strip the input power cable.
9. If the input power cable has a shield, ground the shield under the clamp (360-degree grounding). Twist the shield also into a bundle, mark it with yellow-green insulation tape, fit a cable lug, and connect it to the grounding terminal.



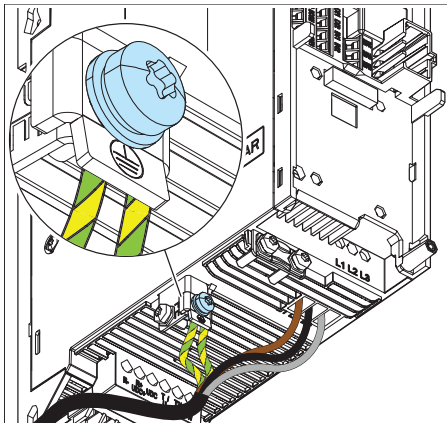

10. Connect the PE conductors of the input power cable to the grounding terminal. Tighten to torque 1.2 N·m (10.6 lbf·in).
11. Connect the phase conductors of the input power cable to the L1, L2 and L3 input terminals. Tighten to torque 0.5 N·m (5 lbf·in).
12. Mechanically attach all of the cables on the outside of the drive.

Connecting the control cables

Before you connect the control cables, make sure that all option modules are installed.

■ Default I/O connection diagrams (ABB standard macro)

The connection diagrams below are valid for the standard drive variant, ie, drive equipped with the RIIO-01 I/O & EIA-485 module. ABB standard macro (parameter 96.04) is in use with the default parameter settings.



Connection	Term. 1)	Description	2)
Analog inputs and outputs			
	SCR	Signal cable shield (screen)	
	AI1	Output frequency: 0...10 V	
	AGND	Analog input circuit common	
	+10V	Reference voltage 10 V DC	
	AI2	Not configured	
	AGND	Analog input circuit common	
	AO1	Output frequency: 0...20 mA	
	AO2	Motor current: 0...20 mA	
	AGND	Analog output circuit common	

Connection	Term. 1)	Description	2)	
Digital inputs and auxiliary voltage output				
	+24V	Aux. voltage output +24 V DC, max. 250 mA ³⁾	×	
	DGND	Aux. voltage output common	×	
	DCOM	Digital input common for all	×	
	DI1	Stop (0) / Start (1)	×	
	DI2	Forward (0) / Reverse (1)	×	
	DI3	Constant output frequency selection⁴⁾		
	DI4	Constant output frequency selection		
	DI5	Ramp set 1 (0) / Ramp set 2 (1)⁵⁾		
	DI6	Not configured		
Relay outputs				
	+24V	Aux. voltage output +24 V DC, max. 250 mA ³⁾		
	DGND	Aux. voltage output common		
	DCOM	Digital input common for all		
	RO1C	Common	Ready run 250 V AC / 30 V DC, 2 A	×
	RO1A	Norm. closed		×
	RO1B	Norm. open		×
	RO2C	Common	Running 250 V AC / 30 V DC, 2 A	
	RO2A	Norm. closed		
	RO2B	Norm. open		
	RO3C	Common	Fault (-1) 250 V AC / 30 V DC, 2 A	
	RO3A	Norm. closed		
	RO3B	Norm. open		
	Embedded EIA-485			
		B+	Embedded fieldbus (EIA-485)	
		A-		
DGND				
	TERM	Termination switch. ON = on. 1 = off.		
Safe torque off				
	SGND	Safe torque off. Factory connection. Both circuits must be closed for the drive to start.	×	
	IN1		×	
	IN2		×	
	OUT1		×	
Auxiliary voltage input/output				
	+24V	Aux. voltage output +24 V DC, max. 250 mA ³⁾		
	DGND	Aux. voltage output common		
	DCOM	Digital input common for all		

1) Terminal size: 0.14...1.5 mm² (26...16 AWG) Tightening torque: 0.5 N·m (0.4 lbf·ft)

2) × = base unit, empty = RIIO-01 module

3) The sum output current from 24 V terminals of base unit and RIIO-01 module must not exceed 250 mA.

4) Drive output frequency:

DI3	DI4	Operation/Parameter
0	0	Set output frequency through AI1
1	0	28.26 Constant frequency 1
0	1	28.27 Constant frequency 2
1	1	28.28 Constant frequency 3

5) See parameters 28.72, 28.73, 28.74 and 28.75.

■ Default fieldbus connection diagram

The connection diagrams are valid for the base unit equipped with an optional fieldbus adapter module. ABB standard macro (parameter 96.04) is in use with its default parameter settings. No fieldbus related settings have been done yet.

Connection	Term. 1)	Description	2)	
Auxiliary voltage output and digital inputs				
	+24V	Aux. voltage output +24 V DC, max. 250 mA	×	
	DGND	Aux. voltage output common	×	
	DCOM	Digital input common for all	×	
	DI1	Stop (0) / Start (1)	×	
	DI2	Forward (0) / Reverse (1)	×	
Relay outputs				
	+24V	Aux. voltage output +24 V DC, max. 250 mA	×	
	DGND	Aux. voltage output common	×	
	DCOM	Digital input common for all	×	
	RO1C	Common	Ready run, 250 V AC / 30 V DC, 2 A	×
	RO1A	Norm. closed		×
	RO1B	Norm. open		×
Safe torque off				
	SGND	Safe torque off. Factory connection. Both circuits must be closed for the drive to start.	×	
	IN1		×	
	IN2		×	
	OUT1		×	

Connection	Term. 1)	Description	2)
Fieldbus connection			
See the fieldbus adapter manual.	DSUB9	+K457 FCAN-01 CANopen	
	DSUB9	+K454 FPBA-01 Profibus DP	
	RJ45×2	+K469 FECA-01 EtherCAT	
	RJ45×2	+K475 FENA-21 Ethernet/IP, Profinet, Modbus TCP	
	RJ45×2	+K470 FEPL-02 Ethernet Powerlink	
	Term.block	+K451 FDNA-01 DeviceNet	
	8P8C×2	+K462 FCNA-01 ControlNet	
	RJ45×2	+K490 FEIP-21 Two-port Modbus/IP adapter	
	RJ45×2	+K491 FMBT-21 Two-port Modbus/TCP adapter	
	RJ45×2	+K492 FPNO-21 Two-port Profinet IO adapter	

1) Terminal size: 0.14...1.5 mm² (26...16 AWG) Tightening torque: 0.5 N·m (0.4 lbf·ft)

2) × = base unit, empty = fieldbus module

■ Control cable connection procedure

Do the connections according to the control macro (parameter 96.04) in use.

Keep the signal wire pairs twisted as near to the terminals as possible to prevent inductive coupling.



WARNING!

Obey the safety instructions of the drive. If you ignore them, injury or death, or damage to the equipment can occur.

If you are not a qualified electrical professional, do not do installation or maintenance work.

1. Stop the drive and do the steps in *Electrical safety precautions (page 14)* before you start the work.
2. Strip a part of the outer shield of the control cable for grounding.
3. Use a cable tie to ground the outer shield to the grounding tab. For 360-degree grounding, use metallic cable ties.
4. Strip the control cable conductors.
5. Connect the conductors to the correct control terminals. Torque the terminals to 0.5 N·m (4.4 lbf·ft).
6. Connect the shields and grounding wires to the SCR terminal. Torque the terminals to 0.5 N·m (4.4 lbf·ft).
7. Mechanically attach the control cables on the outside of the drive.



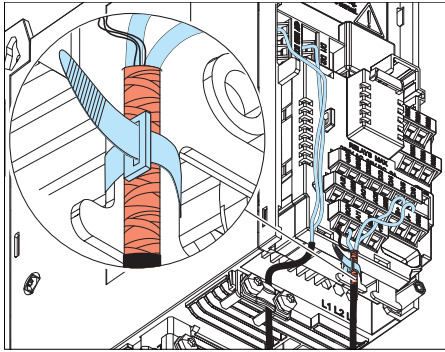

■ **Additional information on the control connections**

Connecting EIA-485 fieldbus cable to the drive

Connect the cable to the EIA-485 terminal on the RIIO-01 I/O & EIA-485 module, which is attached to the drive. The connection diagram is shown below.

The EIA-485 network uses shielded, twisted-pair cable for data signaling with characteristic impedance between 100 and 130 ohm. The distributed capacitance between conductors is less than 100 pF per meter (30 pF per foot). Distributed capacitance between conductors and shield is less than 200 pF per meter (60 pF per foot). Foil or braided shields are acceptable.

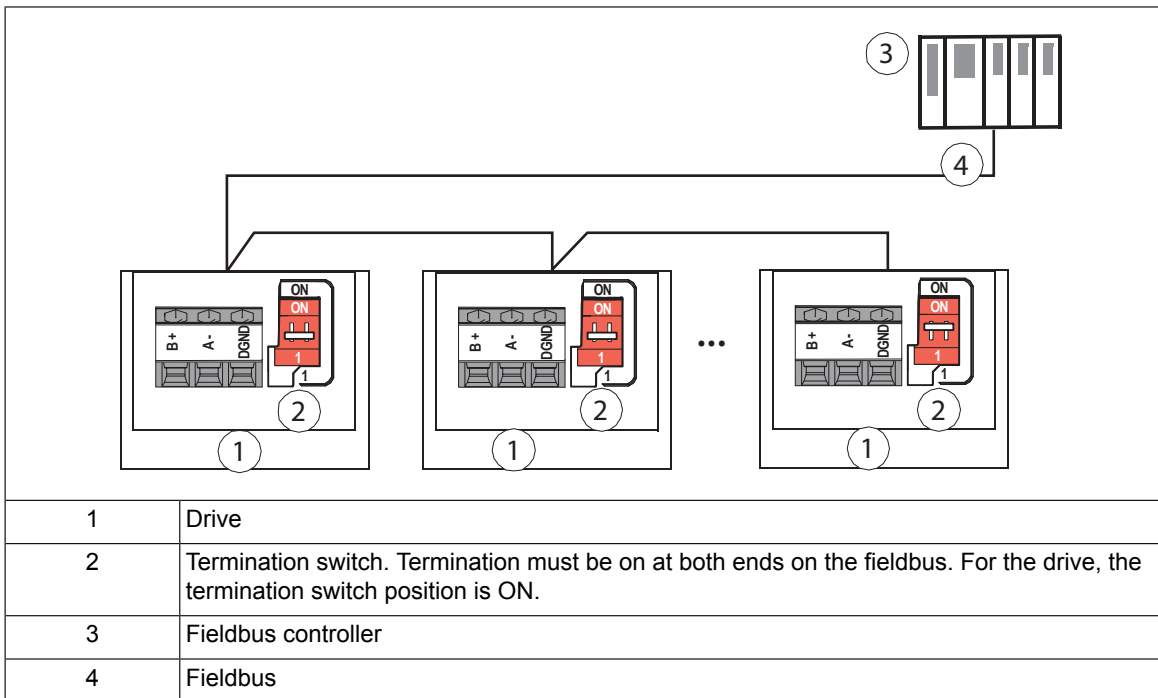

Connection examples of two-wire and three-wire sensors

The figures give examples of connections for a two-wire or three-wire sensor/transmitter that is supplied by the auxiliary voltage output of the drive.

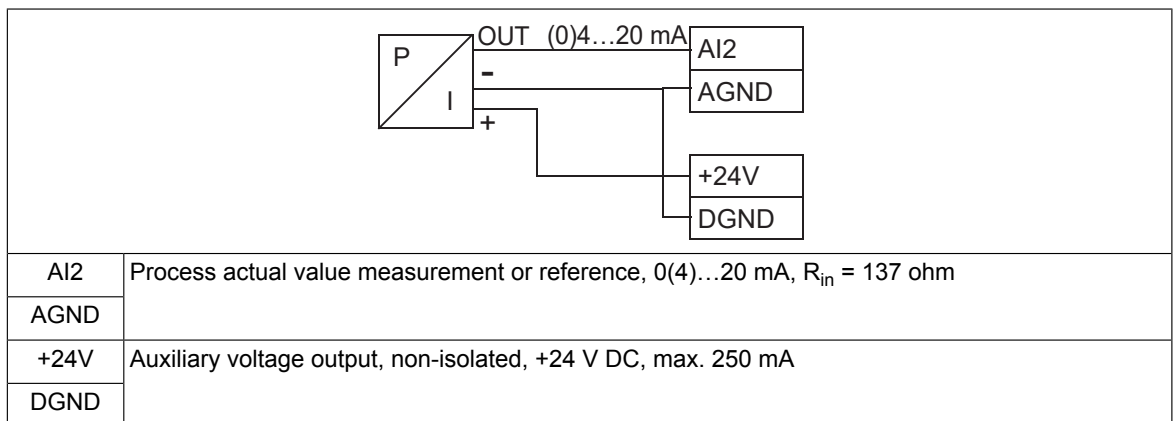
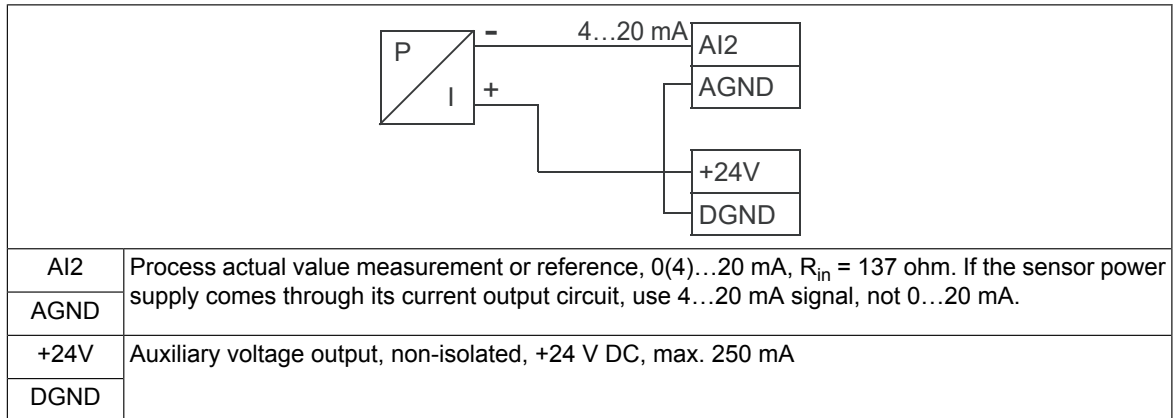

AI and AO (or AI, DI and +10 V) as PTC motor temperature sensor interface



WARNING!

IEC 60664 and IEC 61800-5-1 require double or reinforced insulation between live parts and accessible parts when:

- the accessible parts are not conductive, or
- the accessible parts are conductive, but not connected to the protective earth.

Obey this requirement when you plan the connection of the motor temperature sensor to the drive.

If the motor temperature sensor has a reinforced insulation vs. the motor windings, you can connect it directly to the drive IO interface. This section shows two connection alternatives for the direct I/O connection. If the sensor has no reinforced insulation, you must use another type of connection to fulfill the safety requirements. See [Implementing a motor temperature sensor connection \(page 48\)](#).

See the firmware manual for information on the related Motor thermal protection function, and the required parameter settings.

PTC connection 1

1...3 PTC sensors can be connected in series to an analog input and an analog output. The analog output feeds a constant excitation current of 1.6 mA through the sensor. The sensor resistance increases as the motor temperature rises, as does the voltage over the sensor. The temperature measurement function calculates the resistance of the sensor and generates an indication if overtemperature is detected. Leave the sensor end of the cable shield unconnected.

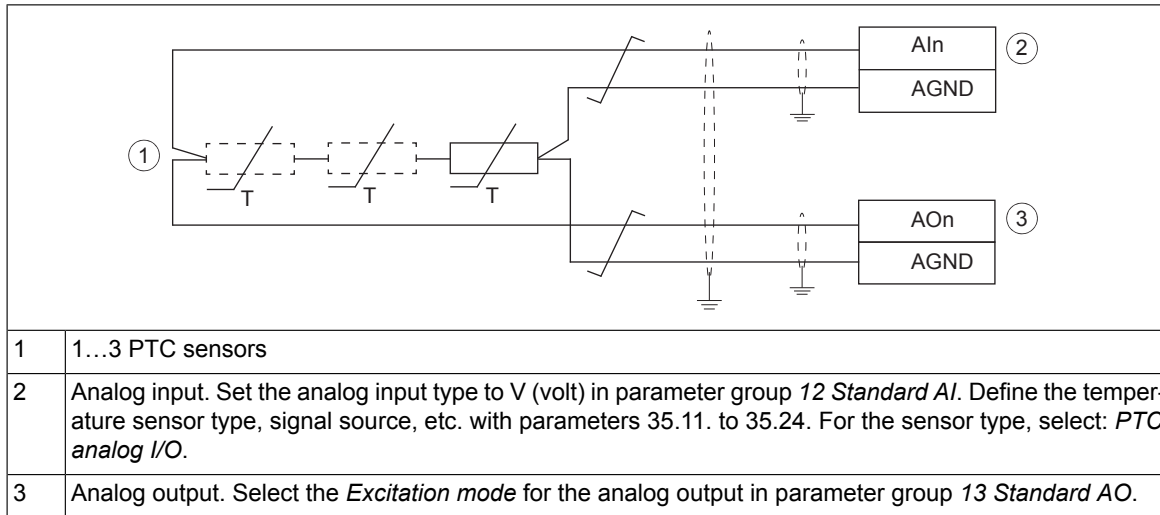

PTC connection 2

If no analog output is available for the PTC connection, it is possible to use a voltage divider connection. 1...3 PTC sensors are connected in series with 10 V reference and digital and analog inputs. The voltage over the digital input internal resistance varies depending on the PTC resistance. The temperature measurement function reads the digital input voltage via the analog input and calculates the PTC resistance.

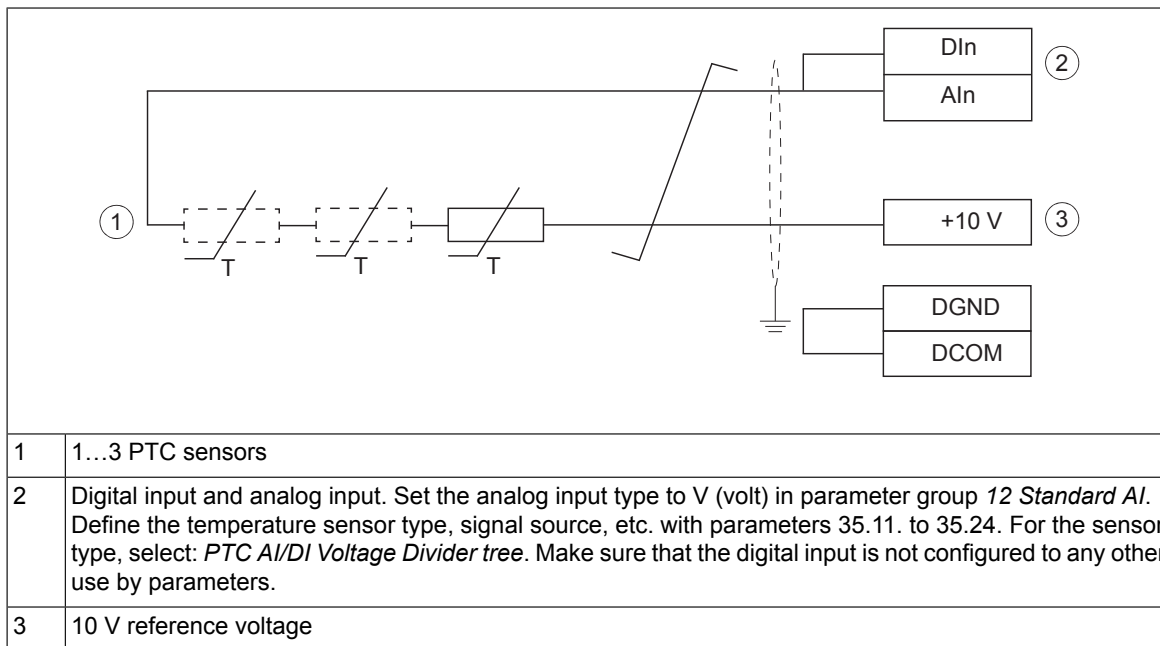

AI1 and AI2 as Pt100, Pt1000, Ni1000, KTY83 and KTY84 sensor inputs



WARNING!

IEC 60664 and IEC 61800-5-1 require double or reinforced insulation between live parts and accessible parts when:

- the accessible parts are not conductive, or
- the accessible parts are conductive, but not connected to the protective earth.

Obey this requirement when you plan the connection of the motor temperature sensor to the drive.

If the motor temperature sensor has a reinforced insulation vs. the motor windings, you can connect it directly to the drive IO interface. This section shows the connection. If the sensor has no reinforced insulation, you must use another type of connection to fulfill the safety requirements. See [Implementing a motor temperature sensor connection \(page 48\)](#).

You can connect temperature measurement sensors (one, two or three Pt100 sensors; one, two or three Pt1000 sensors; or one Ni1000, KTY83 or KTY84) between an analog input and output as shown below. Leave the sensor end of the cable shield unconnected.

See the firmware manual for information on the related Motor thermal protection function.

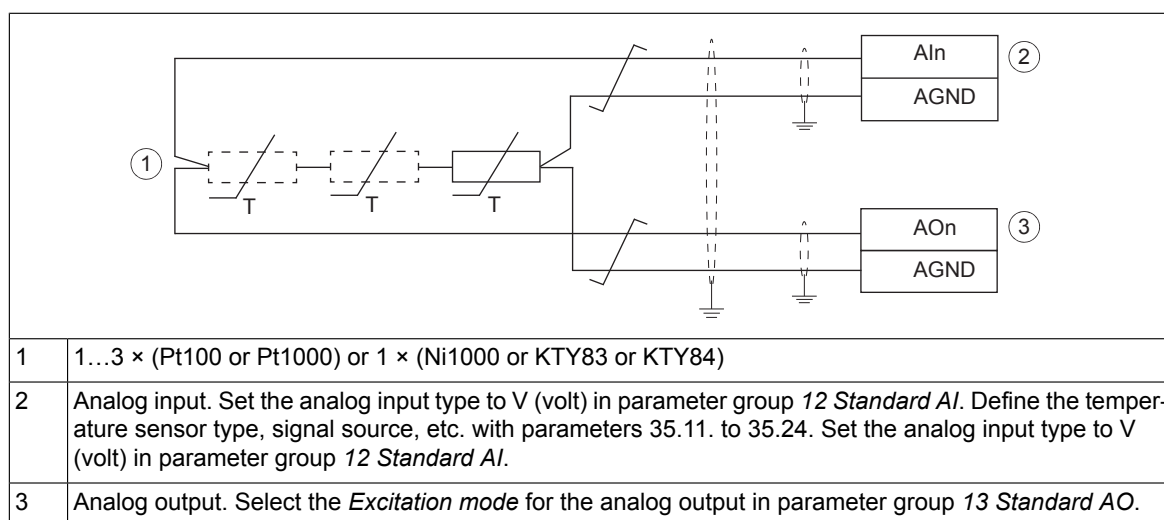

Auxiliary voltage connection

The drive has an auxiliary 24 V DC ($\pm 10\%$) auxiliary power supply terminals both on the base unit and on the RIIO-01 module. You can use it:

- to supply auxiliary power from the drive to external control circuits or option modules
- to supply external auxiliary power to the drive in order to keep the control and cooling in operation also during a drive input power break.

See the technical data for the specifications for the auxiliary power supply terminals (input/output).

If you want to supply power to external control circuits or option modules:

1. Connect the load either to the auxiliary power output on the base unit, or on RIIO-01 module (+24V and DGND terminals).
2. Make sure that you do not exceed the load capacity of the output, or the sum load capacity of both outputs.

If you want to connect an external auxiliary power supply to the drive:

1. Install a BAPO-01 power extension module to the drive. See [Installing options \(page 66\)](#).
2. Connect an external power supply to the +24V and DGND terminals of the base unit.

For more information on the BAPO-01 module, see [BAPO-01 auxiliary power extension module \(page 165\)](#).

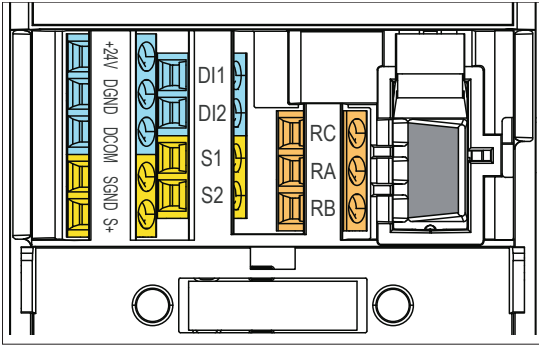

Connecting a PC

To connect a PC to the drive, there are two alternatives:

- If you have an ACS-AP-... assistant control panel attached to the drive, connect the PC through it. Use a USB type A – USB type Mini-B cable between the PC and the panel. The maximum permitted length of the cable is 3 m (9.8 ft).
- If you have the RDUM-01 blank panel, or CDPI-02 panel bus adapter attached, connect the PC through it. Use a BCBL-01 USB to RJ45 converter.

Installing options

The drive has two option module slots:

- Front option: Communication module slot under the front cover.
- Side option: Multifunction extension module slot on the side of the drive.

Refer also to the fieldbus module manual for the installation instructions. For other option modules, see:

- [BAPO-01 auxiliary power extension module \(page 165\)](#)
- [BIO-01 I/O extension module \(page 169\)](#)
- [BREL-01 relay output extension module \(page 173\)](#).

■ Installing a front option



WARNING!

Obey the safety instructions of the drive. If you ignore them, injury or death, or damage to the equipment can occur.

If you are not a qualified electrical professional, do not do installation or maintenance work.

1. Stop the drive and do the steps in section [Electrical safety precautions \(page 14\)](#) before you start the work.
2. Loosen the locking screw of the front cover and lift the front cover up.
3. If the option module has a locking tab, pull it up.
4. Carefully align the option module with the option module slot in the front of the drive.
5. Fully push the option module into position.
6. If applicable, push the locking tab down until it locks.
7. Tighten the locking screw to fully attach and electrically ground the front option.
8. Connect the applicable control cables.

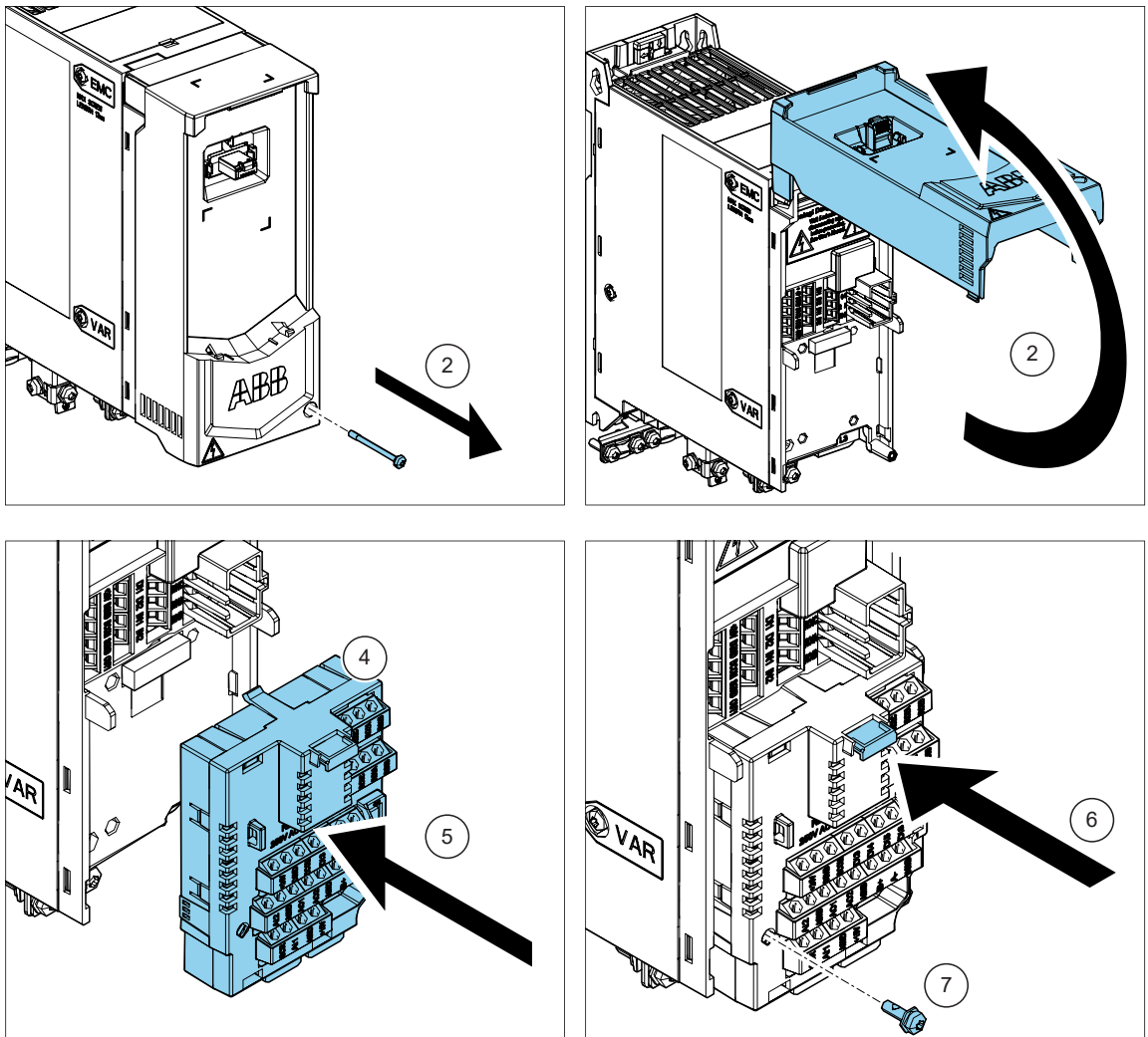

Note: If you have the BIO-01 option module, you can add one additional fieldbus module on top of it.

■ Installing a side option



WARNING!

Obey the safety instructions of the drive. If you ignore them, injury or death, or damage to the equipment can occur.

If you are not a qualified electrical professional, do not do installation or maintenance work.

1. Stop the drive and do the steps in section *Electrical safety precautions (page 14)* before you start the work.
2. Remove the two screws from the front-most grounding clamp at the bottom of the drive.
3. Carefully align the side option with the connectors on the right side of the drive.
4. Fully push the option module into position.
5. Tighten the locking screw of the option module.

6. Attach the grounding bar to the bottom of the side option and to the front ground tab on the drive.
7. Connect the applicable control cables according to control cable connection instructions.

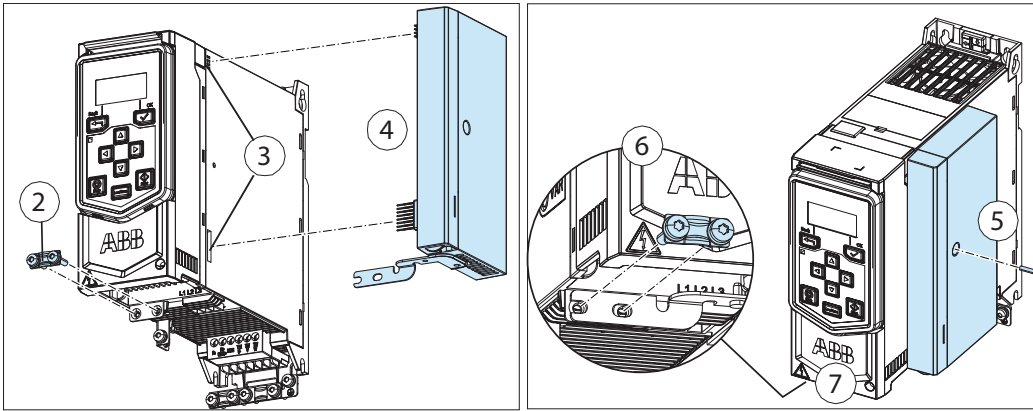

7

Electrical installation – North America

Contents of this chapter

This chapter describes:

- how to measure the insulation
- how to do an earthing system compatibility check, and change the EMC filter or ground-to-phase varistor connection (if necessary)
- how to connect the power and control cabling, install optional modules and connect a PC.

Warnings



WARNING!

Obey the safety instructions of the drive. If you ignore them, injury or death, or damage to the equipment can occur.

If you are not a qualified electrical professional, do not do installation or maintenance work.

Required tools

To do the electrical installation, you need the following tools:

- wire stripper
 - screwdriver or wrench with a set of suitable bits
 - short flat head screwdriver for the I/O terminals
 - multimeter and voltage detector
 - personal protective equipment
-

Measuring the insulation

Measuring the insulation is typically not required in North America.

■ Measuring the insulation of the drive system



WARNING!

Do not do any voltage withstand or insulation resistance tests on any part of the drive as testing can damage the drive. Every drive has been tested for insulation between the main circuit and the chassis at the factory. Also, there are voltage-limiting circuits inside the drive which cut down the testing voltage automatically.

■ Measuring the insulation of the input cable

Before you connect the input power cable to the drive, measure its insulation according to local regulations.

■ Measuring the insulation of the motor and motor cable



WARNING!

Obey the safety instructions of the drive. If you ignore them, injury or death, or damage to the equipment can occur.

If you are not a qualified electrical professional, do not do installation or maintenance work.

1. Stop the drive and do the steps in section [Electrical safety precautions \(page 14\)](#) before you start the work.
2. Make sure that the motor cable is disconnected from the drive output terminals.
3. Measure the insulation resistance between each phase conductor and the protective earth conductor. Use a measuring voltage of 1000 V DC. The insulation resistance of an ABB motor must exceed 100 Mohm (reference value at 25 °C [77 °F]). For the insulation resistance of other motors, consult the manufacturer's instructions.

Note: Moisture inside the motor casing reduces the insulation resistance. If moisture is suspected, dry the motor and repeat the measurement.

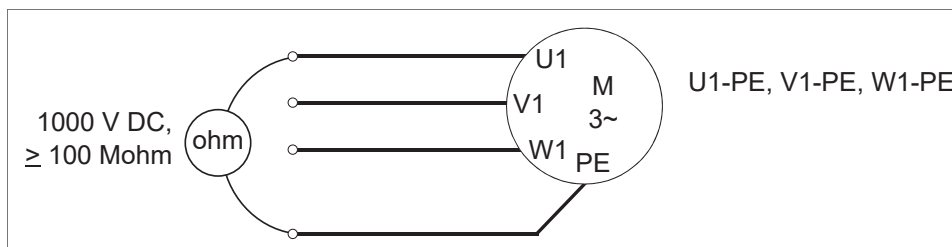

■ Measuring the insulation of brake resistor and resistor cable



WARNING!

Obey the safety instructions of the drive. If you ignore them, injury or death, or damage to the equipment can occur.

If you are not a qualified electrical professional, do not do installation or maintenance work.

1. Stop the drive and do the steps in section [Electrical safety precautions \(page 14\)](#) before you start the work.
2. Make sure that the resistor cable is connected to the resistor and disconnected from the drive output terminals.
3. At the drive end, connect the R+ and R- conductors of the resistor cable together. Measure the insulation resistance between the conductors and the PE conductor with a measuring voltage of 1000 V DC. The insulation resistance must be higher than 1 Mohm.

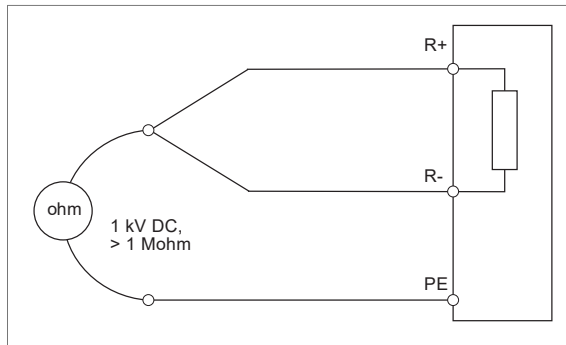

Earthing system compatibility check – North America

This section is valid for the UL(NEC) drive types. For the IEC drives types, see [Earthing system compatibility check – IEC \(page 53\)](#).

■ EMC filter

The drive has an internal EMC filter as standard. However, for the UL(NEC) drive types, the filter is disconnected as default. The filter is typically not needed in North American installations.

If you are concerned with EMC issues, and install the drive to a symmetrically grounded TN-S system, you can connect the internal EMC filter. See [Disconnecting ground-to-phase varistor, or connecting EMC filter](#).

Note: When the internal EMC filter is disconnected, the electromagnetic compatibility of the drive is reduced.

■ Ground-to-phase varistor

The drive is equipped with an internal ground-to-phase varistor as standard. For frame sizes R1, R3 and R4, the varistor is connected as default. For frame size R2, the varistor is disconnected as default.

A drive with the ground-to-phase varistor connected can be installed to a symmetrically grounded TN-S system. If you install the drive to another system, you may need to disconnect the varistor. See [When to disconnect ground-to-phase varistor, or connect EMC filter](#).

■ When to disconnect ground-to-phase varistor, or connect EMC filter

The table below shows different earthing systems, and when to disconnect ground-to-phase varistor, or connect EMC filter, ie, maintain or remove the factory default EMC screw or VAR screw.



WARNING!

Failure to remove the metal VAR screw, when indicated in the table, can cause danger or drive failure.



WARNING!

Do not install the metal EMC screw in systems other than the symmetrically grounded TN-S system. It can cause danger, or damage to the drive.

Screw label	Factory default screw material	Earthing systems and factory default EMC or VAR screw		
		Symmetrically grounded TN-S systems, i.e., center grounded-wye (A)	Corner-grounded delta (B1), midpoint-grounded delta (B2) and TT (D) systems	IT systems (ungrounded or high-resistance grounded) (C)
EMC	Plastic	Can install the metal screw. ¹⁾	Maintain the plastic screw.	Maintain the plastic screw.
VAR	Frames R1, R3, R4: metal	Maintain the metal screw.	Maintain the metal screw.	Remove the metal screw.
	Frame R2: plastic	Maintain the plastic screw.	Maintain the plastic screw.	Maintain the plastic screw.

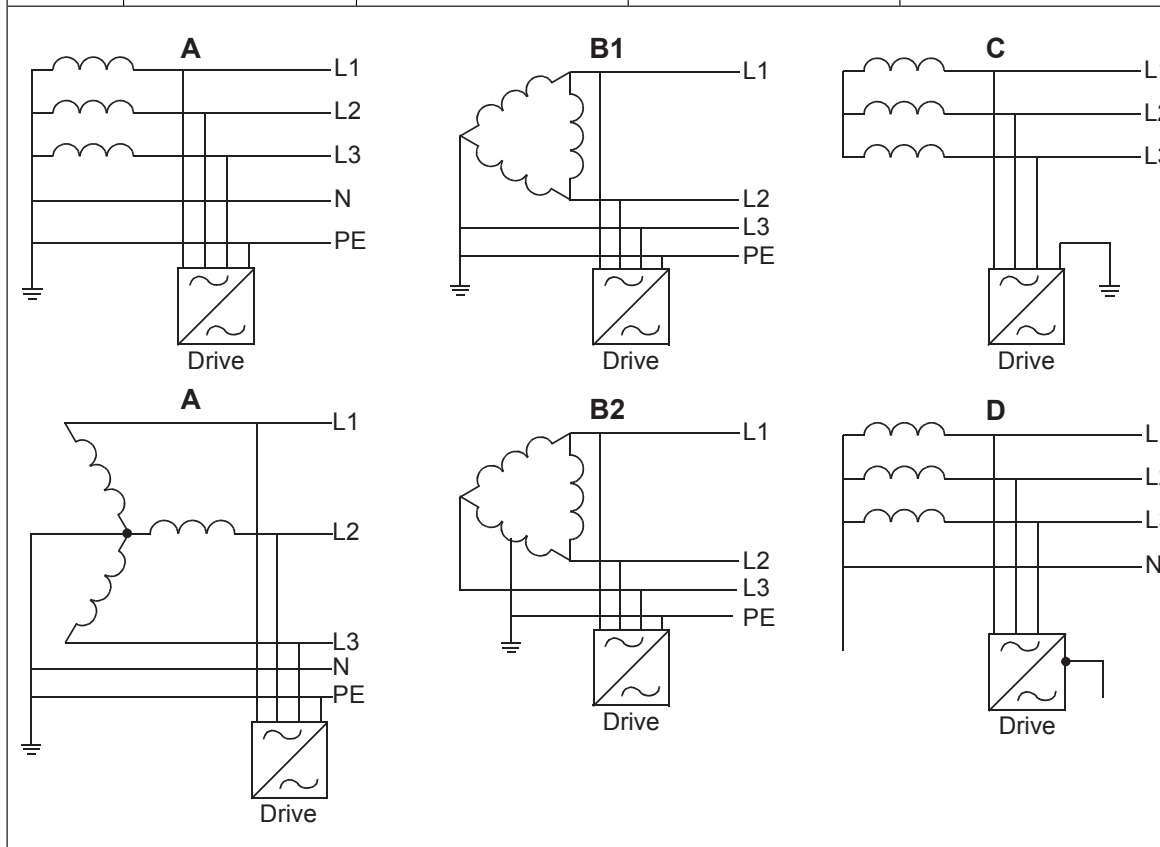

¹⁾ If you are concerned with EMC issues, you can install the metal screw and connect the EMC filter. The metal screw is included in the drive delivery.

■ Disconnecting the ground-to-phase varistor, or connecting the EMC filter

Before you proceed, see *When to disconnect ground-to-phase varistor, or connect EMC filter (page 71)*. Obey the guidelines.

1. Stop the drive and disconnect it from the power line.
2. Wait 5 minutes to let the intermediate circuit capacitors discharge.
3. To disconnect the varistor, remove the metal VAR screw.
4. To connect the EMC filter, remove the plastic EMC screw, and replace it with the metal screw included in the drive delivery.

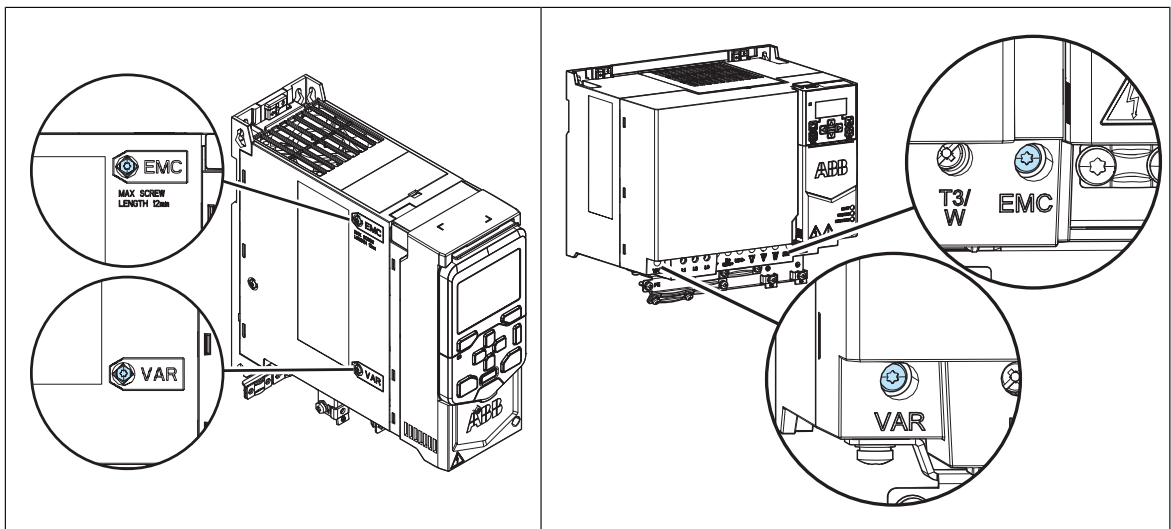

■ Identifying the earthing system of the electrical power network



WARNING!

Only a qualified electrical professional may do the work instructed in this section. Depending on the installation site, the work may even be categorized as live working. Proceed only if you are an electrical professional certified for the work. Obey the local regulations. If you ignore them, injury or death can occur.

To identify the earthing system, find out the supply transformer connection. If that is not possible, measure these voltages at the distribution board, and use the table below to define the earthing system type.

1. input voltage line to line (U_{L-L})
2. input voltage line 1 to ground (U_{L1-G})
3. input voltage line 2 to ground (U_{L2-G})
4. input voltage line 3 to ground (U_{L3-G}).

The table below shows the line-to-ground voltages in relation to the line-to-line voltage for each earthing system.

U_{L-L}	U_{L1-G}	U_{L2-G}	U_{L3-G}	Electrical power system type
X	$0.58 \cdot X$	$0.58 \cdot X$	$0.58 \cdot X$	Symmetrically grounded TN system (TN-S system)
X	$1.0 \cdot X$	$1.0 \cdot X$	0	Corner-grounded delta system (nonsymmetrical)
X	$0.866 \cdot X$	$0.5 \cdot X$	$0.5 \cdot X$	Midpoint-grounded delta system (nonsymmetrical)
X	Varying level versus time	Varying level versus time	Varying level versus time	IT systems (ungrounded or high-resistance-grounded [>30 ohms]) nonsymmetrical
X	Varying level versus time	Varying level versus time	Varying level versus time	TT system (the protective earth connection for the consumer is provided by a local earth electrode, and there is another independently installed at the generator)

Connecting the power cables – North America (wiring in conduits)

Use insulated wires suitable for the installation in electric conduits. See the National Electric Code and Local ordinances.

Note: ABB prefers the use of a symmetrical shielded motor cable (VFD cable).



■ Connection diagram

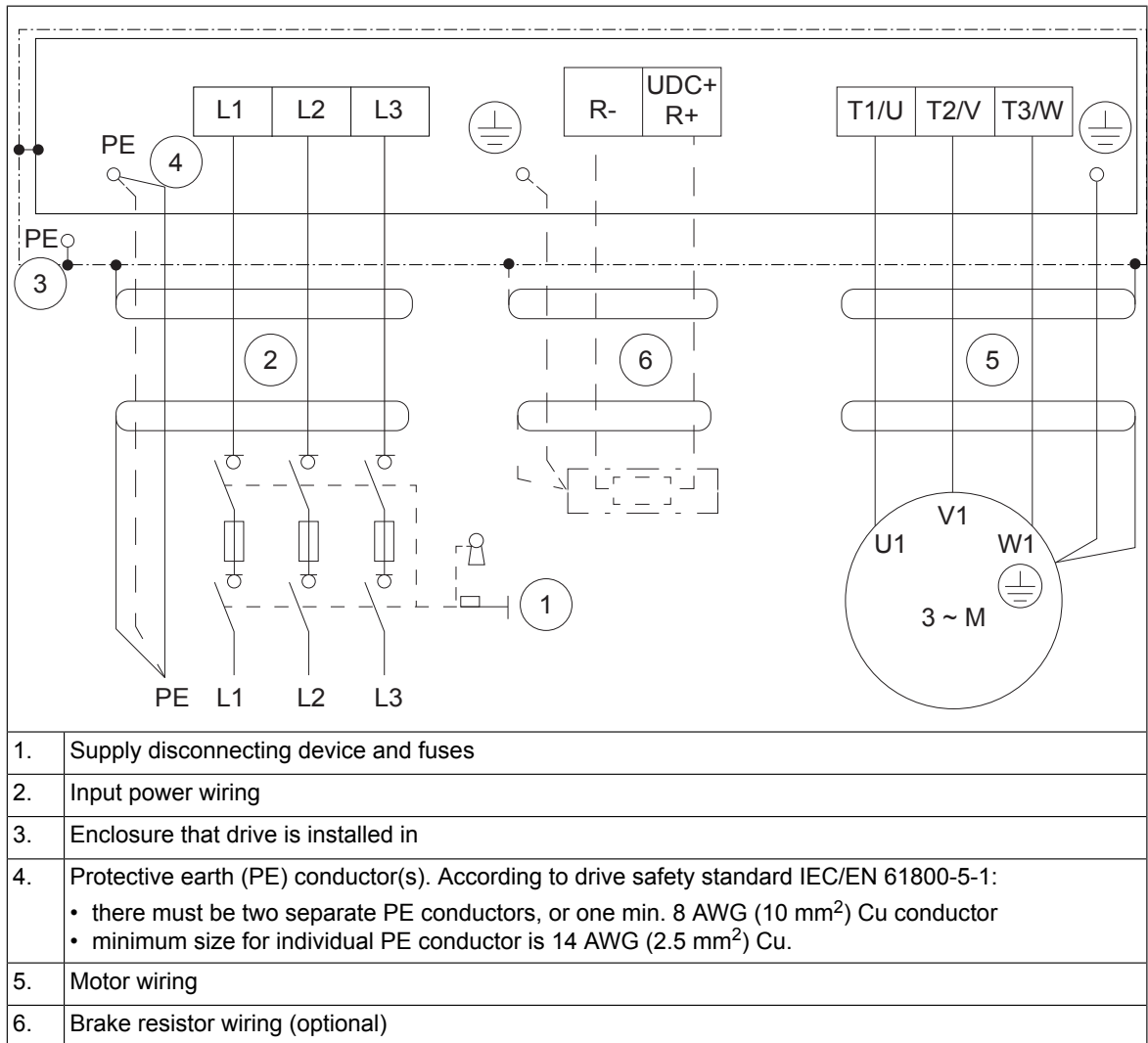

■ Connection procedure



WARNING!

Obey the safety instructions of the drive. If you ignore them, injury or death, or damage to the equipment can occur.

If you are not a qualified electrical professional, do not do installation or maintenance work.

1. Stop the drive and do the steps in section *Electrical safety precautions (page 14)* before you start the work.
2. Install the conduits, and attach them to the cable entry plate of the enclosure that the drive is installed in.
3. Make sure of a proper grounding of the conduit at the cable entry.
4. Strip the conductor ends and pull the conductors through the conduits.
5. Open the locking screw of the front cover and lift the front cover up.

6. Connect the conductors to the drive. Tighten the phase conductors to 5 lbf-in (0.5 N·m), and PE conductors to 10.6 lbf-in (1.2 N·m).
7. Connect the other ends of the conductors. Make sure of a proper grounding of the conduit at the cable entry.

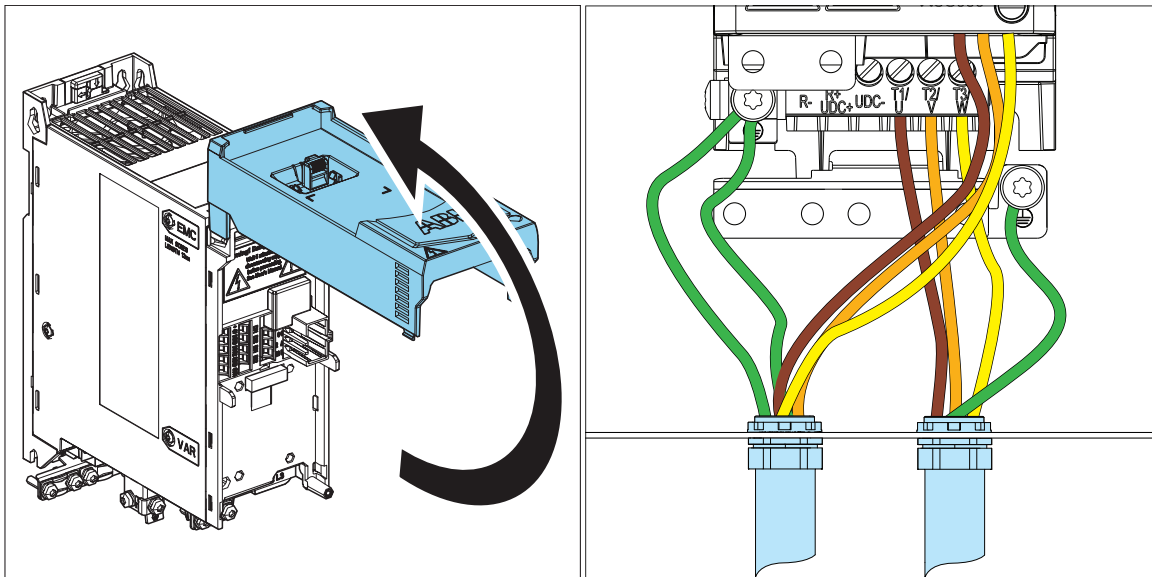

Connecting the control cables

Before you connect the control cables, make sure that all option modules are installed.

■ Default I/O connection diagrams (ABB standard macro)

The connection diagrams below are valid for the standard drive variant, ie, drive equipped with the RIIO-01 I/O & EIA-485 module. ABB standard macro (parameter 96.04) is in use with the default parameter settings.

Connection	Term. 1)	Description	2)
Analog inputs and outputs			
	SCR	Signal cable shield (screen)	
	AI1	Output frequency: 0...10 V	
	AGND	Analog input circuit common	
	+10 V	Reference voltage 10 V DC	
	AI2	Not configured	
	AGND	Analog input circuit common	
	AO1	Output frequency: 0...20 mA	
	AO2	Motor current: 0...20 mA	
AGND	Analog output circuit common		

Connection	Term. 1)	Description	2)	
Digital inputs and auxiliary voltage output				
	+24V	Aux. voltage output +24 V DC, max. 250 mA ³⁾	×	
	DGND	Aux. voltage output common	×	
	DCOM	Digital input common for all	×	
	DI1	Stop (0) / Start (1)	×	
	DI2	Forward (0) / Reverse (1)	×	
	DI3	Constant output frequency selection⁴⁾		
	DI4	Constant output frequency selection		
	DI5	Ramp set 1 (0) / Ramp set 2 (1)⁵⁾		
	DI6	Not configured		
Relay outputs				
	+24V	Aux. voltage output +24 V DC, max. 250 mA ³⁾		
	DGND	Aux. voltage output common		
	DCOM	Digital input common for all		
	RO1C	Common	Ready run 250 V AC / 30 V DC, 2 A	×
	RO1A	Norm. closed		×
	RO1B	Norm. open		×
	RO2C	Common	Running 250 V AC / 30 V DC, 2 A	
	RO2A	Norm. closed		
	RO2B	Norm. open		
	RO3C	Common	Fault (-1) 250 V AC / 30 V DC, 2 A	
	RO3A	Norm. closed		
	RO3B	Norm. open		
	Embedded EIA-485			
		B+	Embedded fieldbus (EIA-485)	
		A-		
DGND				
	TERM	Termination switch. ON = on. 1 = off.		
Safe torque off				
	SGND	Safe torque off. Factory connection. Both circuits must be closed for the drive to start.	×	
	IN1		×	
	IN2		×	
	OUT1		×	
Auxiliary voltage input/output				
	+24V	Aux. voltage output +24 V DC, max. 250 mA ³⁾		
	DGND	Aux. voltage output common		
	DCOM	Digital input common for all		

1) Terminal size: 0.14...1.5 mm² (26...16 AWG) Tightening torque: 0.5 N·m (0.4 lbf·ft)

2) × = base unit, empty = RIIO-01 module

3) The sum output current from 24 V terminals of base unit and RIIO-01 module must not exceed 250 mA.

4) Drive output frequency:

DI3	DI4	Operation/Parameter
0	0	Set output frequency through AI1
1	0	28.26 Constant frequency 1
0	1	28.27 Constant frequency 2
1	1	28.28 Constant frequency 3

5) See parameters 28.72, 28.73, 28.74 and 28.75.

■ Default fieldbus connection diagram

The connection diagrams are valid for the base unit equipped with an optional fieldbus adapter module. ABB standard macro (parameter 96.04) is in use with its default parameter settings. No fieldbus related settings have been done yet.

Connection	Term. 1)	Description	2)	
Auxiliary voltage output and digital inputs				
	+24V	Aux. voltage output +24 V DC, max. 250 mA	×	
	DGND	Aux. voltage output common	×	
	DCOM	Digital input common for all	×	
	DI1	Stop (0) / Start (1)	×	
	DI2	Forward (0) / Reverse (1)	×	
Relay outputs				
	+24V	Aux. voltage output +24 V DC, max. 250 mA	×	
	DGND	Aux. voltage output common	×	
	DCOM	Digital input common for all	×	
	RO1C	Common	Ready run, 250 V AC / 30 V DC, 2 A	×
	RO1A	Norm. closed		×
	RO1B	Norm. open		×
Safe torque off				
	SGND	Safe torque off. Factory connection. Both circuits must be closed for the drive to start.	×	
	IN1		×	
	IN2		×	
	OUT1		×	

Connection	Term. 1)	Description	2)
Fieldbus connection			
See the fieldbus adapter manual.	DSUB9	+K457 FCAN-01 CANopen	
	DSUB9	+K454 FPBA-01 Profibus DP	
	RJ45×2	+K469 FECA-01 EtherCAT	
	RJ45×2	+K475 FENA-21 Ethernet/IP, Profinet, Modbus TCP	
	RJ45×2	+K470 FEPL-02 Ethernet Powerlink	
	Term.block	+K451 FDNA-01 DeviceNet	
	8P8C×2	+K462 FCNA-01 ControlNet	
	RJ45×2	+K490 FEIP-21 Two-port Modbus/IP adapter	
	RJ45×2	+K491 FMBT-21 Two-port Modbus/TCP adapter	
	RJ45×2	+K492 FPNO-21 Two-port Profinet IO adapter	

1) Terminal size: 0.14...1.5 mm² (26...16 AWG) Tightening torque: 0.5 N·m (0.4 lbf·ft)

2) × = base unit, empty = fieldbus module

■ Control cable connection procedure

Do the connections according to the control macro (parameter 96.04) in use.

Keep the signal wire pairs twisted as near to the terminals as possible to prevent inductive coupling.



WARNING!

Obey the safety instructions of the drive. If you ignore them, injury or death, or damage to the equipment can occur.

If you are not a qualified electrical professional, do not do installation or maintenance work.

1. Stop the drive and do the steps in *Electrical safety precautions (page 14)* before you start the work.
2. Strip a part of the outer shield of the control cable for grounding.
3. Use a cable tie to ground the outer shield to the grounding tab. For 360-degree grounding, use metallic cable ties.
4. Strip the control cable conductors.
5. Connect the conductors to the correct control terminals. Torque the terminals to 0.5 N·m (4.4 lbf·ft).
6. Connect the shields and grounding wires to the SCR terminal. Torque the terminals to 0.5 N·m (4.4 lbf·ft).
7. Mechanically attach the control cables on the outside of the drive.



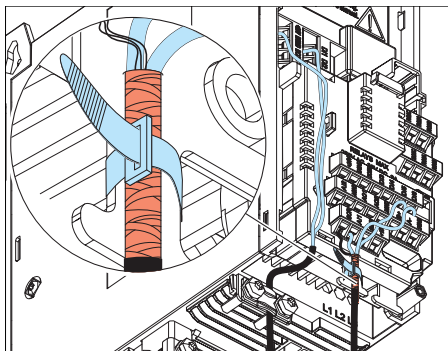

■ **Additional information on the control connections**

Connecting EIA-485 fieldbus cable to the drive

Connect the cable to the EIA-485 terminal on the RIIO-01 I/O & EIA-485 module, which is attached to the drive. The connection diagram is shown below.

The EIA-485 network uses shielded, twisted-pair cable for data signaling with characteristic impedance between 100 and 130 ohm. The distributed capacitance between conductors is less than 100 pF per meter (30 pF per foot). Distributed capacitance between conductors and shield is less than 200 pF per meter (60 pF per foot). Foil or braided shields are acceptable.

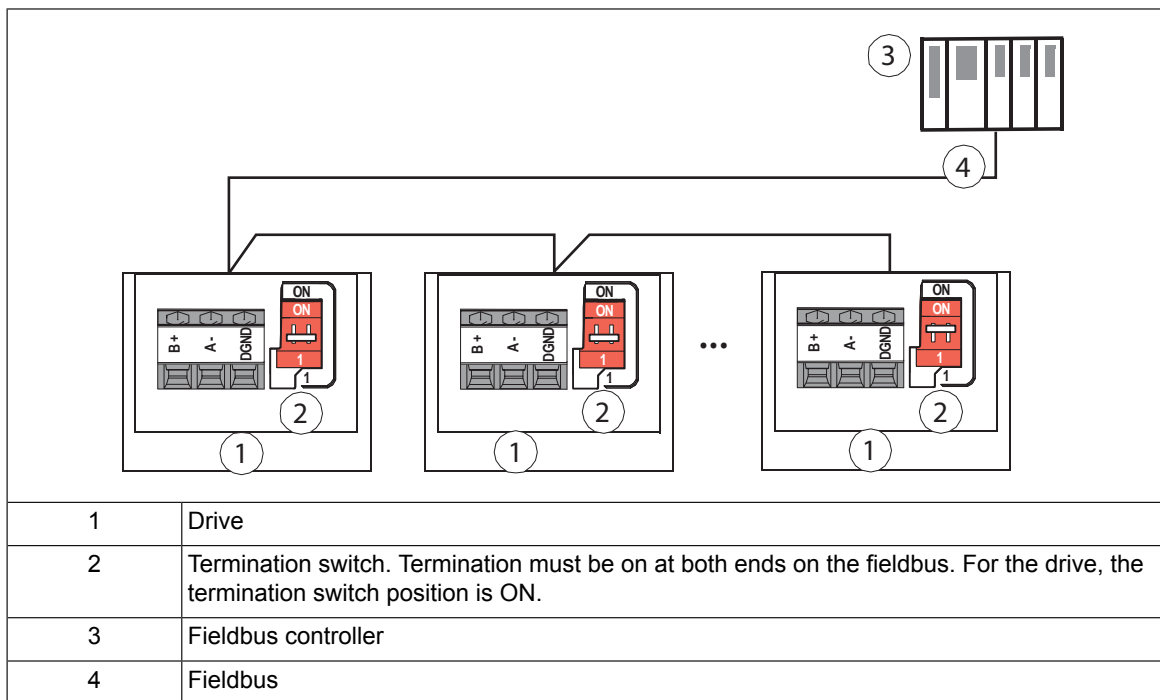

Connection examples of two-wire and three-wire sensors

The figures give examples of connections for a two-wire or three-wire sensor/transmitter that is supplied by the auxiliary voltage output of the drive.

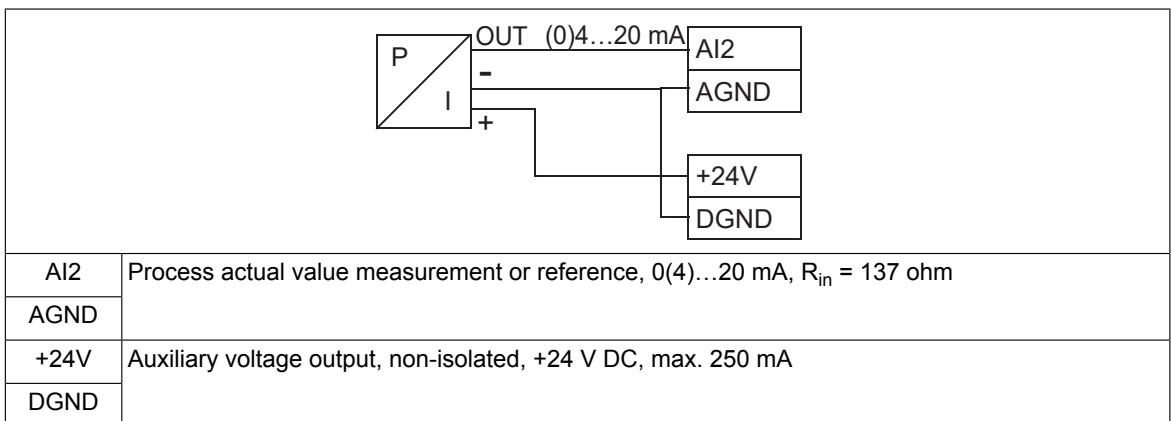
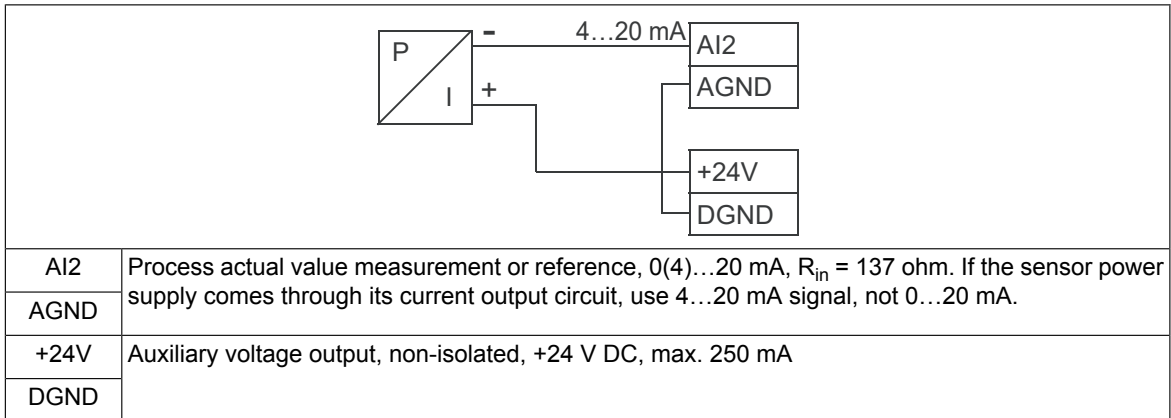

AI and AO (or AI, DI and +10 V) as PTC motor temperature sensor interface



WARNING!

IEC 60664 and IEC 61800-5-1 require double or reinforced insulation between live parts and accessible parts when:

- the accessible parts are not conductive, or
- the accessible parts are conductive, but not connected to the protective earth.

Obey this requirement when you plan the connection of the motor temperature sensor to the drive.

If the motor temperature sensor has a reinforced insulation vs. the motor windings, you can connect it directly to the drive IO interface. This section shows two connection alternatives for the direct I/O connection. If the sensor has no reinforced insulation, you must use another type of connection to fulfill the safety requirements. See [Implementing a motor temperature sensor connection \(page 48\)](#).

See the firmware manual for information on the related Motor thermal protection function, and the required parameter settings.

PTC connection 1

1...3 PTC sensors can be connected in series to an analog input and an analog output. The analog output feeds a constant excitation current of 1.6 mA through the sensor. The sensor resistance increases as the motor temperature rises, as does the voltage over the sensor. The temperature measurement function calculates the resistance of the sensor and generates an indication if overtemperature is detected. Leave the sensor end of the cable shield unconnected.

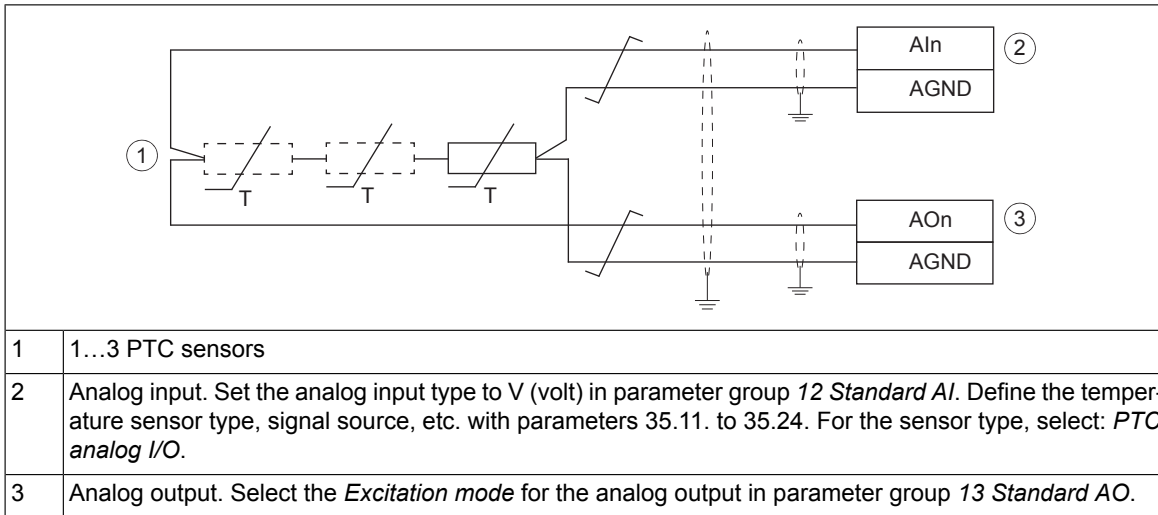

PTC connection 2

If no analog output is available for the PTC connection, it is possible to use a voltage divider connection. 1...3 PTC sensors are connected in series with 10 V reference and digital and analog inputs. The voltage over the digital input internal resistance varies depending on the PTC resistance. The temperature measurement function reads the digital input voltage via the analog input and calculates the PTC resistance.

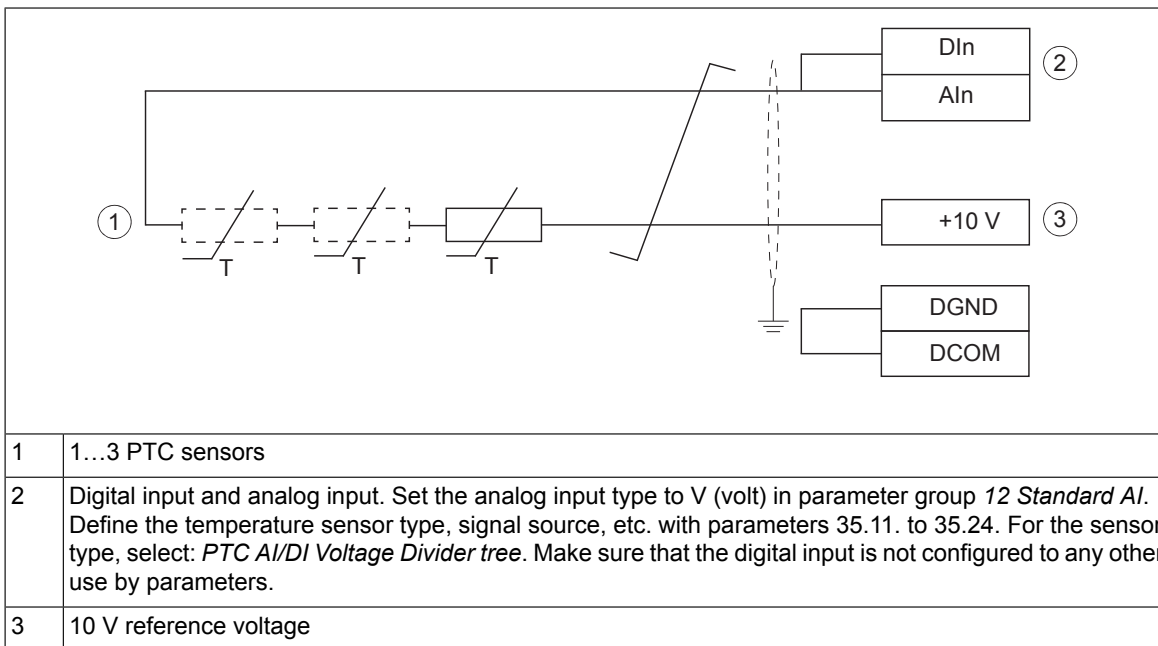

AI1 and AI2 as Pt100, Pt1000, Ni1000, KTY83 and KTY84 sensor inputs



WARNING!

IEC 60664 and IEC 61800-5-1 require double or reinforced insulation between live parts and accessible parts when:

- the accessible parts are not conductive, or
- the accessible parts are conductive, but not connected to the protective earth.

Obey this requirement when you plan the connection of the motor temperature sensor to the drive.

If the motor temperature sensor has a reinforced insulation vs. the motor windings, you can connect it directly to the drive IO interface. This section shows the connection. If the sensor has no reinforced insulation, you must use another type of connection to fulfill the safety requirements. See [Implementing a motor temperature sensor connection \(page 48\)](#).

You can connect temperature measurement sensors (one, two or three Pt100 sensors; one, two or three Pt1000 sensors; or one Ni1000, KTY83 or KTY84) between an analog input and output as shown below. Leave the sensor end of the cable shield unconnected.

See the firmware manual for information on the related Motor thermal protection function.

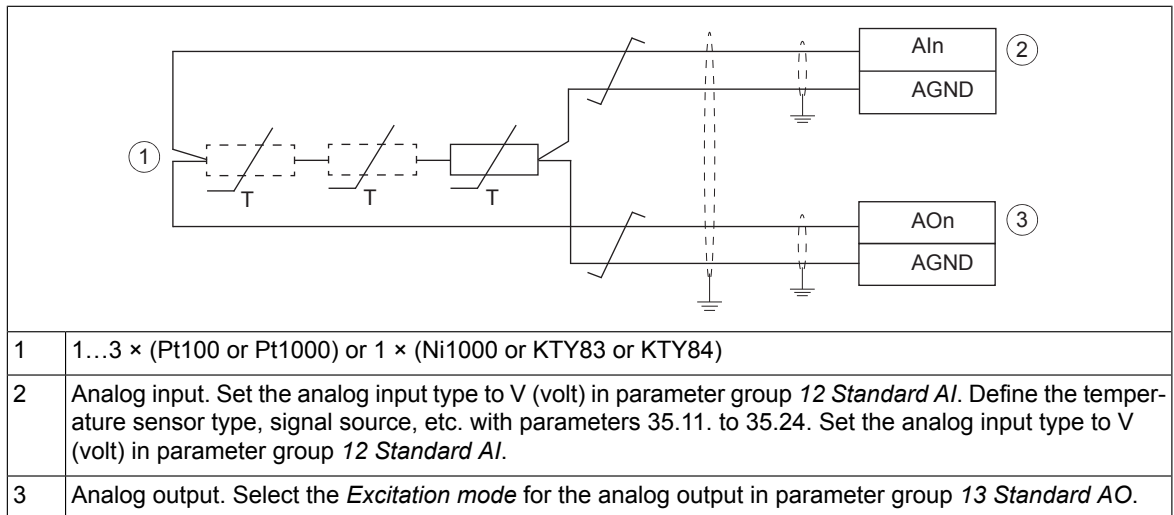

Auxiliary voltage connection

The drive has an auxiliary 24 V DC ($\pm 10\%$) auxiliary power supply terminals both on the base unit and on the RIIO-01 module. You can use it:

- to supply auxiliary power from the drive to external control circuits or option modules
- to supply external auxiliary power to the drive in order to keep the control and cooling in operation also during a drive input power break.

See the technical data for the specifications for the auxiliary power supply terminals (input/output).

If you want to supply power to external control circuits or option modules:

1. Connect the load either to the auxiliary power output on the base unit, or on RIIO-01 module (+24V and DGND terminals).
2. Make sure that you do not exceed the load capacity of the output, or the sum load capacity of both outputs.

If you want to connect an external auxiliary power supply to the drive:

1. Install a BAPO-01 power extension module to the drive. See [Installing options \(page 66\)](#).
2. Connect an external power supply to the +24V and DGND terminals of the base unit.

For more information on the BAPO-01 module, see [BAPO-01 auxiliary power extension module \(page 165\)](#).

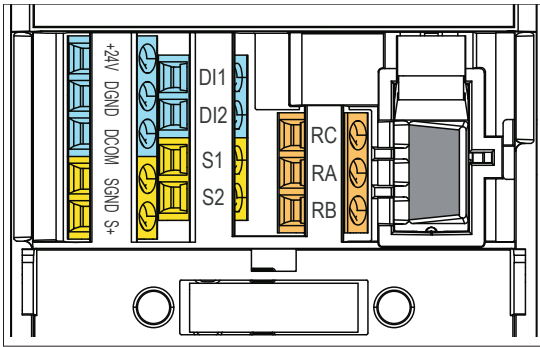

Connecting a PC

To connect a PC to the drive, there are two alternatives:

- If you have an ACS-AP-... assistant control panel attached to the drive, connect the PC through it. Use a USB type A – USB type Mini-B cable between the PC and the panel. The maximum permitted length of the cable is 3 m (9.8 ft).
- If you have the RDUM-01 blank panel, or CDPI-02 panel bus adapter attached, connect the PC through it. Use a BCBL-01 USB to RJ45 converter.

Installing options

The drive has two option module slots:

- Front option: Communication module slot under the front cover.
- Side option: Multifunction extension module slot on the side of the drive.

Refer also to the fieldbus module manual for the installation instructions. For other option modules, see:

- [BAPO-01 auxiliary power extension module \(page 165\)](#)
- [BIO-01 I/O extension module \(page 169\)](#)
- [BREL-01 relay output extension module \(page 173\)](#).

■ Installing a front option



WARNING!

Obey the safety instructions of the drive. If you ignore them, injury or death, or damage to the equipment can occur.

If you are not a qualified electrical professional, do not do installation or maintenance work.

1. Stop the drive and do the steps in section [Electrical safety precautions \(page 14\)](#) before you start the work.
2. Loosen the locking screw of the front cover and lift the front cover up.
3. If the option module has a locking tab, pull it up.
4. Carefully align the option module with the option module slot in the front of the drive.
5. Fully push the option module into position.
6. If applicable, push the locking tab down until it locks.
7. Tighten the locking screw to fully attach and electrically ground the front option.
8. Connect the applicable control cables.

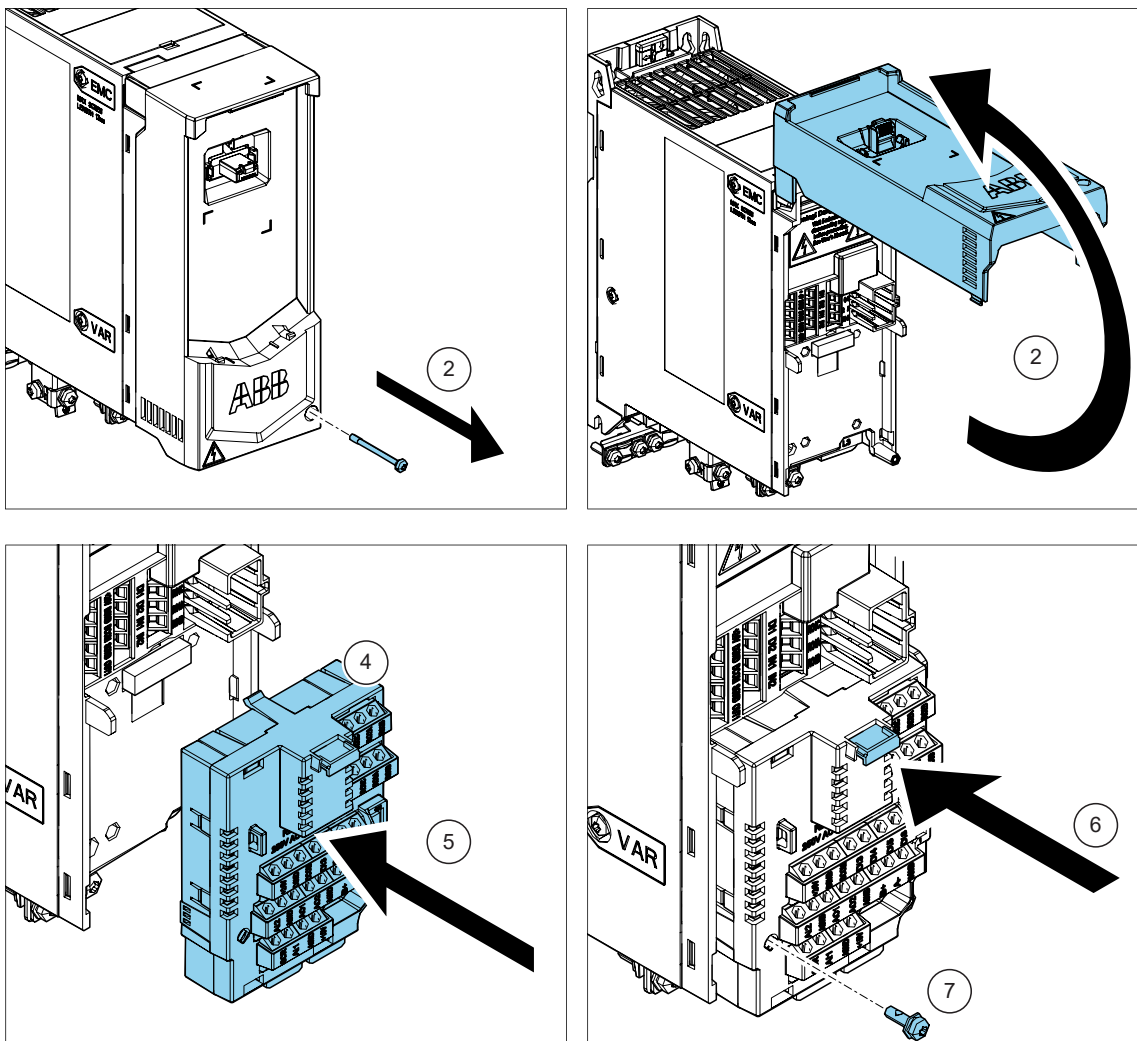

Note: If you have the BIO-01 option module, you can add one additional fieldbus module on top of it.

■ Installing a side option



WARNING!

Obey the safety instructions of the drive. If you ignore them, injury or death, or damage to the equipment can occur.

If you are not a qualified electrical professional, do not do installation or maintenance work.

1. Stop the drive and do the steps in section *Electrical safety precautions (page 14)* before you start the work.
2. Remove the two screws from the front-most grounding clamp at the bottom of the drive.
3. Carefully align the side option with the connectors on the right side of the drive.
4. Fully push the option module into position.
5. Tighten the locking screw of the option module.

6. Attach the grounding bar to the bottom of the side option and to the front ground tab on the drive.
7. Connect the applicable control cables according to control cable connection instructions.

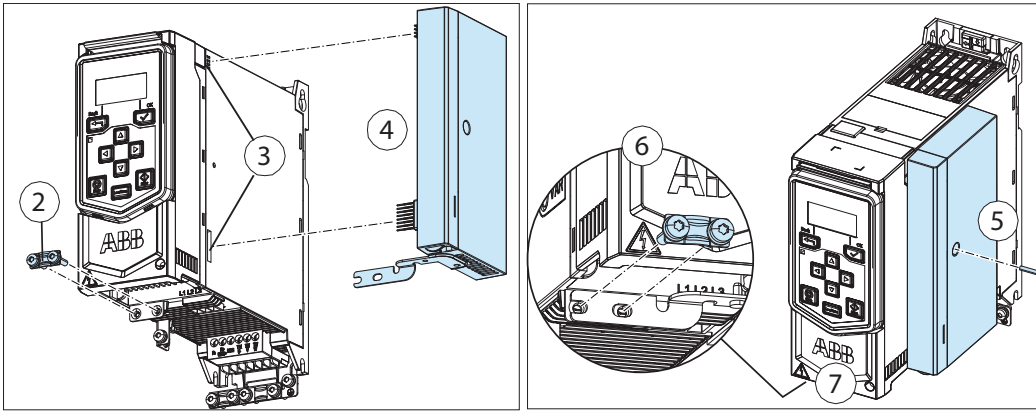

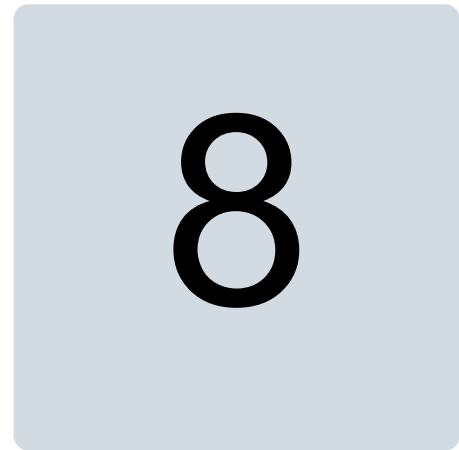

Installation checklist of the drive

Contents of this chapter

This chapter contains a checklist of the mechanical and electrical installation of the drive.

Checklist

Examine the mechanical and electrical installation of the drive before start-up. Go through the checklist together with another person.



WARNING!

Obey the safety instructions of the drive. If you ignore them, injury or death, or damage to the equipment can occur.

If you are not a qualified electrical professional, do not do installation or maintenance work.



WARNING!

Stop the drive and do the steps in section *Electrical safety precautions (page 14)* before you start the work.

Make sure that ...	<input checked="" type="checkbox"/>
The ambient operating conditions meet the drive ambient conditions specification, and enclosure rating (IP code or UL enclosure type).	<input type="checkbox"/>
The supply voltage matches the nominal input voltage of the drive. See the type designation label.	<input type="checkbox"/>
The drive is attached securely on an even, vertical and non-flammable wall.	<input type="checkbox"/>
The cooling air flows freely in and out of the drive.	<input type="checkbox"/>
<u>If the drive is connected to a network other than a symmetrically grounded TN-S system:</u> You have done all the required modifications (for example, you may need to disconnect the EMC filter or ground-to-phase varistor). See the electrical installation instructions.	<input type="checkbox"/>

88 Installation checklist of the drive

Make sure that ...	<input checked="" type="checkbox"/>
Appropriate AC fuses and main disconnect are installed.	<input type="checkbox"/>
There is an adequately sized protective earth (ground) conductor(s) between the drive and the switchboard, the conductor is connected to correct terminal, and the terminal is tightened to the correct torque. Proper grounding has also been measured according to the regulations.	<input type="checkbox"/>
The input power cable is connected to the correct terminals, the phase order is correct, and the terminals are tightened to the correct torque.	<input type="checkbox"/>
There is an adequately sized protective earth (ground) conductor between the motor and the drive, and the conductor is connected to the correct terminal, and the terminal is tightened to the correct torque. Proper grounding has also been measured according to the regulations.	<input type="checkbox"/>
The motor cable is connected to the correct terminals, the phase order is correct, and the terminals are tightened to the correct torque.	<input type="checkbox"/>
The motor cable is routed away from other cables.	<input type="checkbox"/>
No power factor compensation capacitors are connected to the motor cable.	<input type="checkbox"/>
<u>If an external brake resistor is connected to the drive:</u> There is an adequately sized protective earth (ground) conductor between the brake resistor and the drive, and the conductor is connected to the correct terminal, and the terminals are tightened to the correct torque. Proper grounding has also been measured according to the regulations.	<input type="checkbox"/>
<u>If an external brake resistor is connected to the drive:</u> The brake resistor is connected to the correct terminals, and the terminals are tightened to the correct torque.	<input type="checkbox"/>
<u>If an external brake resistor is connected to the drive:</u> The brake resistor cable is routed away from other cables.	<input type="checkbox"/>
The control cables are connected to the correct terminals, and the terminals are tightened to the correct torque.	<input type="checkbox"/>
<u>If a drive bypass connection will be used:</u> The direct-on-line contactor of the motor and the drive output contactor are either mechanically and/or electrically interlocked, that is, they cannot be closed at the same time. A thermal overload device must be used for protection when bypassing the drive. Refer to local codes and regulations.	<input type="checkbox"/>
There are no tools, foreign objects or dust from drilling inside the drive.	<input type="checkbox"/>
The area in front of the drive is clean: the drive cooling fan cannot draw any dust or dirt inside.	<input type="checkbox"/>
Drive covers and cover of the motor connection box are in place.	<input type="checkbox"/>
<u>If the drive is stored for longer than one year:</u> The electrolytic DC capacitors in the DC link of the drive are reformed. Refer to <i>Converter module capacitor reforming instructions</i> (3BFE64059629 [English]).	<input type="checkbox"/>
The motor and the driven equipment are ready for power-up.	<input type="checkbox"/>



Maintenance

Contents of this chapter

The chapter contains the preventive maintenance instructions.

Maintenance intervals

The table below shows the maintenance tasks which can be done by the end user. The complete maintenance schedule is available on the Internet (www.abb.com/drivesservices). For more information, consult your local ABB Service representative (www.abb.com/searchchannels).

Recommended action	Annually
Connections and environment	
Quality of the supply voltage	P
Spare parts	
Spare parts	I
Reform DC circuit capacitors (spare modules).	P
Inspections	
Tightness of the cable and busbar terminals.	I
Ambient conditions (dustiness, moisture and temperature)	I
Clean the heatsink.	P

Maintenance task/object	Years from start-up						
	3	6	9	12	15	18	21
Cooling fans							
Main cooling fan (frames R1...R4).		R		R		R	
Batteries							
Control panel battery			R			R	

Symbols

- I Inspection** (visual inspection and maintenance action if needed)
- P Performance** of on/off-site work (commissioning, tests, measurements or other work)
- R Replacement**

Maintenance and component replacement intervals are based on the assumption that the equipment is operated within the specified ratings and ambient conditions. ABB recommends annual drive inspections to ensure the highest reliability and optimum performance.

Note: Long term operation near the specified maximum ratings or ambient conditions may require shorter maintenance intervals for certain components. Consult your local ABB Service representative for additional maintenance recommendations.

Cleaning the heatsink

The drive module heatsink fins pick up dust from the cooling air. The drive runs into overtemperature warnings and faults if the heatsink is not clean. When necessary, clean the heatsink as follows.



WARNING!

Obey the safety instructions of the drive. If you ignore them, injury or death, or damage to the equipment can occur.

If you are not a qualified electrical professional, do not do installation or maintenance work.



WARNING!

Use a vacuum cleaner with antistatic hose and nozzle, and wear a grounding wristband. Using a normal vacuum cleaner creates static discharges which can damage circuit boards.

1. Stop the drive and do the steps in section *Electrical safety precautions (page 14)* before you start the work.
2. Remove the drive module from the cabinet.
3. Remove the module cooling fan(s). See the separate instructions.
4. Blow dry, clean and oil-free compressed air from bottom to top and simultaneously use a vacuum cleaner at the air outlet to trap the dust. If there is a risk of dust entering adjoining equipment, do the cleaning in another room.
5. Reinstall the cooling fan.

Replacing the cooling fans

Parameter *05.04 Fan on-time counter* shows the running time of the cooling fan. After you replace the fan, reset the fan counter. Refer to the firmware manual.

You can get replacement fans from ABB. Use only ABB specified spare parts.

■ To replace the cooling fan for frame sizes R1, R2 and R3



WARNING!

Obey the safety instructions of the drive. If you ignore them, injury or death, or damage to the equipment can occur.

If you are not a qualified electrical professional, do not do installation or maintenance work.

1. Before you start the work, do the steps in [Electrical safety precautions \(page 14\)](#).
2. Use a suitable flat screwdriver to open the fan cover.
3. Carefully lift the fan cover out of the drive. Note that the fan cover holds the cooling fan.

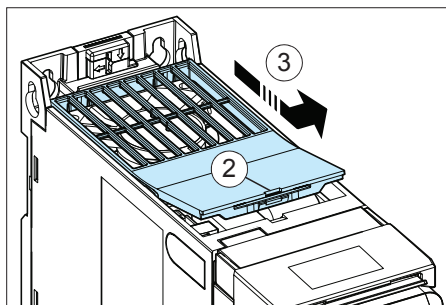

4. Remove the fan power cable from the cable slot in the drive.
5. Disconnect the fan power cable.

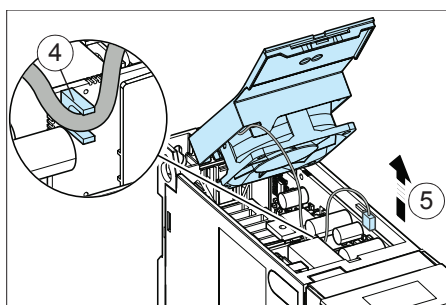

6. Free the fan clips and remove the fan from the fan cover.

7. Install the new fan into the fan cover. Make sure that the air flow is in the correct direction. The air flows in from the bottom of the drive and out from the top of the drive.

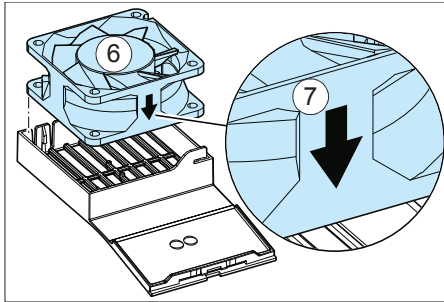

8. Connect the fan power cable.
9. Put the fan power cable into the cable slot in the drive.

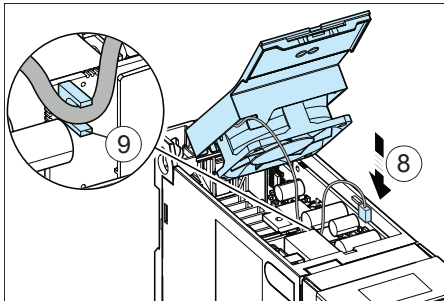

10. Carefully put the fan cover into position in the drive. Make sure that the fan power cable is routed correctly.
11. Push the cover to lock into position.

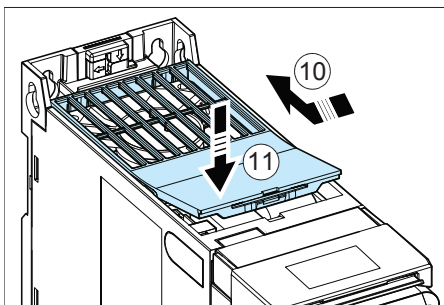

■ To replace the cooling fan for frame R4



WARNING!

Obey the safety instructions of the drive. If you ignore them, injury or death, or damage to the equipment can occur.

If you are not a qualified electrical professional, do not do installation or maintenance work.

1. Before you start the work, do the steps in *Electrical safety precautions (page 14)*.
2. Use a suitable flat screwdriver to open the fan cover.

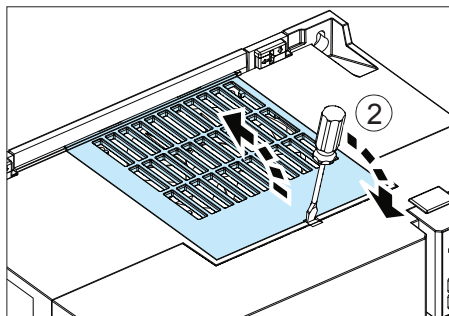

3. Lift out the fan cover and set it aside.

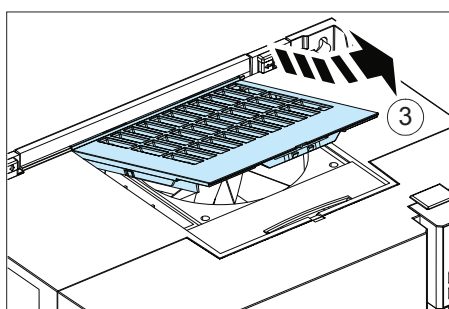

4. Lift and pull the fan from its base.
5. Unplug the fan power cable from the extension cable connector.

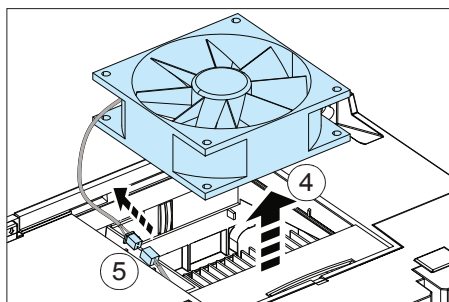

6. Replace the old fan carefully. Pay attention to the correct installation direction of the fan by following the arrow markings on the fan, they must point up and to the left. When installed correctly, the fan creates suction within the drive and blows it outwards.
7. Attach the fan power cable to the connector.

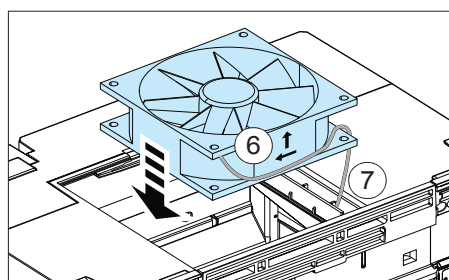

8. Place the fan cover back on the frame.
-

9. Push the cover to lock into position.

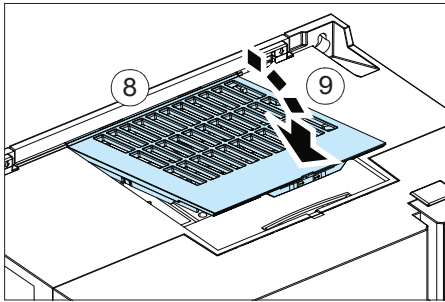

Capacitors

The DC link of the drive contains several electrolytic capacitors. Operating time, load, and surrounding air temperature have an effect on the life of the capacitors. Capacitor life can be extended by decreasing the surrounding air temperature.

Capacitor failure is usually followed by damage to the unit and an input cable fuse failure, or a fault trip. If you think that any capacitors in the drive have failed, contact ABB.

■ Reforming the capacitors

The capacitors must be reformed if the drive has not been powered (either in storage or unused) for a year or more. The manufacturing date is on the type designation label. For information on reforming the capacitors, see *Converter module capacitor reforming instructions* (3BFE64059629 [English]) in the ABB Library (<https://library.abb.com/en>).

10

Technical data

Contents of this chapter

The chapter contains the technical specifications of the drive, such as ratings, sizes and technical requirements as well as provisions for fulfilling the requirements for CE, UL and other approval marks.

Electrical ratings

■ IEC ratings

IEC type ACS480-04-...	Input current		Output ratings							Frame
	No choke	With choke	Max. current	Nominal use		Light-duty use		Heavy-duty use		
	I_1	I_1	I_{max}	I_N	P_N	I_{Ld}	P_{Ld}	I_{Hd}	P_{Hd}	
	A	A	A	A	kW	A	kW	A	kW	
3-phase $U_N = 400$ V, 50 Hz										
02A7-4	4.2	2.6	3.2	2.6	0.75	2.5	0.75	1.8	0.55	R1
03A4-4	5.3	3.3	4.7	3.3	1.1	3.1	1.1	2.6	0.75	R1
04A1-4	6.4	4.0	5.9	4.0	1.5	3.8	1.5	3.3	1.1	R1
05A7-4	9.0	5.6	7.2	5.6	2.2	5.3	2.2	4.0	1.5	R1
07A3-4	11.5	7.2	10.1	7.2	3.0	6.8	3.0	5.6	2.2	R1
09A5-4	15.0	9.4	13.0	9.4	4.0	8.9	4.0	7.2	3.0	R1
12A7-4	20.2	12.6	16.9	12.6	5.5	12.0	5.5	9.4	4.0	R2
018A-4	27.2	17.0	22.7	17.0	7.5	16.2	7.5	12.6	5.5	R3
026A-4	40.0	25.0	30.6	25.0	11.0	23.8	11.0	17.0	7.5	R3
033A-4	45.0	32.0	45.0	32.0	15.0	30.5	15.0	25.0	11.0	R4
039A-4	50.0	38.0	57.6	38.0	18.5	36.0	18.5	32.0	15.0	R4
046A-4	56.0	45.0	68.4	45.0	22.0	42.8	22.0	38.0	18.5	R4
050A-4	60.0	50.0	81.0	50.0	22.0	48.0	22.0	45.0	22.0	R4

See *Notes and definitions (page 98)*.

■ **UL (NEC) ratings**

UL (NEC) type ACS480-04-...	Input current		Output ratings							Frame
	No choke	with choke	Max. current	Nominal use		Light-duty use		Heavy-duty use		
	I_1	I_1	I_{max}	I_N	P_N	I_{Ld}	P_{Ld}	I_{Hd}	P_{Hd}	
	A	A	A	A	hp	A	hp	A	hp	
3-phase $U_N = 480$ V, 60 Hz										
02A1-4	3.4	2.1	2.9	2.1	1.0	2.1	1.0	1.6	0.75	R1
03A0-4	4.8	3.0	3.8	3.0	1.5	3.0	1.5	2.1	1.0	R1
03A5-4	5.6	3.5	5.4	3.5	2.0	3.5	2.0	3.0	1.5	R1
04A8-4	7.7	4.8	6.1	4.8	3.0	4.8	2.0	3.4	2.0	R1
06A0-4	9.6	6.0	7.2	6.0	3.0	6.0	3.0	4.0	2.0	R1
07A6-4	12.2	7.6	8.6	7.6	5.0	7.6	5.0	4.8	3.0	R1
011A-4	17.6	11.0	13.7	11.0	7.5	11.0	7.5	7.6	5.0	R2
014A-4	22.4	14.0	19.8	14.0	10.0	14.0	10.0	11.0	7.5	R3
021A-4	33.6	21.0	25.2	21.0	15.0	21.0	15.0	14.0	10.0	R3
027A-4	37.9	27.0	37.8	27.0	20.0	27.0	20.0	12.0	15.0	R4
034A-4	44.7	34.0	48.6	34.0	25.0	34.0	25.0	27.0	20.0	R4
042A-4	50.4	42.0	72.0	42.0	30.0	42.0	30.0	40.0	30.0	R4

See [Notes and definitions \(page 98\)](#).

■ Notes and definitions

The ratings are valid at a surrounding air temperature of 50 °C (122 °F), with the default drive switching frequency of 4 kHz (parameter 97.01), and with an installation altitude below 1000 m (3281 ft).

U_N	Nominal input voltage of the drive. For input voltage range U1, see section Electrical power network specification (page 112) .
I_1	Nominal input current. Continuous rms input current (for dimensioning cables and fuses).
I_{max}	Maximum output current. Available for two seconds every 10 minutes when output frequency is below 9 Hz. Otherwise maximum current is $1.5 \times I_{Hd}$. Maximum current setting (parameter 30.17) can also limit the value.
I_N	Nominal output current. Maximum continuous rms output current allowed (no overload).
P_N	Typical motor power in nominal use (no overloading). The kilowatt ratings apply to most IEC 4-pole (400 V, 50 Hz) motors. The horsepower ratings apply to most NEMA 4-pole motors (460 V, 60 Hz).
I_{Ld}	Continuous rms output current. Allows 10% overload for 1 minute every 10 minutes.
P_{Ld}	Typical motor power in light-duty use (10% overload). The kilowatt ratings apply to most IEC 4-pole (400 V, 50 Hz) motors. The horsepower ratings apply to most NEMA 4-pole motors (460 V, 60 Hz).
I_{Hd}	Continuous rms output current. Allows 50% overload for 1 minute every 10 minutes.
P_{Hd}	Typical motor power in heavy-duty use (50% overload). The kilowatt ratings apply to most IEC 4-pole (400 V, 50 Hz) motors. The horsepower ratings apply to most NEMA 4-pole motors (460 V, 60 Hz).

■ Sizing

ABB recommends the DriveSize PC tool for selecting the drive, motor and gear combination (<http://new.abb.com/drives/software-tools/drivesize>). You can also use the ratings tables.

Output derating

The load capacity (I_N , I_{Ld} , I_{Hd} ; note that I_{max} is not derated) decreases in certain situations. In such situations, where full motor power is required, oversize the drive so that the total derated output current provides sufficient current for the motor to reach the full power.

If several situations are present at a time, the effects of derating are cumulative.

Note:

- The motor can also have a derating on it.
- The DriveSize dimensioning PC tool available from ABB (<http://new.abb.com/drives/software-tools/drivesize>) is also suitable for derating.

Example 1, IEC: How to calculate the derated current

The drive type is ACS480-04-018A-4, which has drive output current of 17 A. Calculate the derated drive output current (I_N) at 4 kHz switching frequency, at 1500 m altitude and at 55 °C surrounding air temperature.

Switching frequency derating: From the table, no derating is needed at 4 kHz.

Altitude derating: The derating factor for 1500 m is

$$1 - \frac{1500 \text{ m} - 1000 \text{ m}}{10000 \text{ m}} = 0.95$$

The derated drive output current becomes

$$I_N = 17 \text{ A} \cdot 0.95 = 16.15 \text{ A}$$

Surrounding air temperature derating: From the table, the derating factor for 55 °C surrounding air temperature is

$$1 - \frac{55 \text{ C} - 50 \text{ C}}{100 \text{ C}} = 0.95$$

The derated drive output current becomes

$$I_N = 16.15 \text{ A} \cdot 0.95 = 15.34 \text{ A}$$

Example 1, UL (NEC): How to calculate the derated current

Drive type is ACS480-04-014A-4, which has drive output current of 14 A. Calculate the derated drive output current (I_N) at 4 kHz switching frequency, at 6000 ft (1829 m) altitude and at 131 °F (55 °C) surrounding air temperature.

Switching frequency derating: From the table, no derating is needed at 4 kHz.

Altitude derating: The derating factor for 6000 ft is

$$1 - \frac{6000 \text{ ft} - 3281 \text{ ft}}{32810 \text{ ft}} = 0.917$$

The derated drive output current becomes

$$I_N = 14 \text{ A} \cdot 0.917 = 12.84 \text{ A}$$

Surrounding air temperature derating: The derating factor for 131 °F surrounding air temperature is

$$1 - \frac{131 \text{ F} - 122 \text{ F}}{180 \text{ F}} = 0.95$$

The derated drive output current becomes

$$I_N = 12.84 \cdot 0.95 \text{ A} = 12.2 \text{ A}$$

Example 2, IEC: How to calculate the required drive

If your application requires a nominal motor current of 6.0 A at 8 kHz switching frequency, the supply voltage is 400 V and the drive is situated at 1800 m altitude and at 35 °C surrounding air temperature, calculate the required drive size.

Altitude derating: The derating factor for 1800 m is

$$1 - \frac{1800 \text{ m} - 1000 \text{ m}}{10000 \text{ m}} = 0.92$$

Surrounding air temperature derating: No derating needed for 35 °C surrounding air temperature.

To determine if the derated current of a drive is enough for the application, multiply the nominal drive output current (I_N) by all the applicable derating factors. For example, drive type ACS480-04-12A7-4 has a nominal output current of 12.6 A. From the table, the switching frequency derating for this drive type is 0.68 at 8 kHz. Calculate the derated drive output current:

$$I_N = 12.6 \cdot 0.68 \cdot 0.92 = 7.88 \text{ A}$$

Example 2, UL (NEC): How to calculate the required drive

If your application requires a maximum of 12.0 A of motor current with a 10% overload for one minute every ten minutes (I_{Ld}) at 8 kHz switching frequency, the supply voltage is 480 V and the drive is situated at 5500 ft (1676 m) altitude and at 95 °F (35 °C) surrounding air temperature, calculate the required drive size.

Altitude derating: The derating factor for 5500 ft (1676 m) is

$$1 - \frac{5500 \text{ ft} - 3281 \text{ ft}}{32810 \text{ ft}} = 0.932$$

Surrounding air temperature derating: No derating needed for 95 °F surrounding air temperature.

To determine if the derated current of a drive is enough for the application, multiply the drive output current for light-duty use (I_{Ld}) by all the applicable derating factors. For example, drive type ACS480-04-21A-4 has an output current of 21 A at 480 V. From the table, the switching frequency derating for this drive type is 0.67 at 8 kHz. Calculate the derated drive output current:

$$I_{Ld} = 21 \cdot 0.67 \cdot 0.932 = 13.11 \text{ A}$$

■ Surrounding air temperature derating

Frame	Temperature range	Derating
All	Up to +50°C Up to +122°F	No derating
R1...R3	+50...+60°C +122...140°F	Output current decreases by 1% for every additional 1 °C (1.8 F).
R4	+50...+60°C +122...140°F	Output current decreases by 1% for every additional 1 °C (1.8 F) on: <ul style="list-style-type: none"> • ACS480-04-033A-4 • ACS480-04-046A-4 Output current decreases by 2% for every additional 1 °C on: <ul style="list-style-type: none"> • ACS480-04-039A-4 • ACS480-04-050A-4 • ACS480-04-055A-2

■ Switching frequency derating

The output current is calculated by multiplying the current given in the rating table by the derating factor given in the table.

If you change the minimum switching frequency with parameter 97.02 *Minimum switching frequency*, derate according to the table. Changing parameter 97.01 *Switching frequency reference* does not require derating.

Frame R4: If the application is cyclic and the surrounding air temperature is constant over +40°C, keep the minimum switching frequency in its default value (parameter 97.02 = 1.5 kHz). Higher switching frequencies decrease the product life time and/or limits the performance in the temperature range +40...60°C.

IEC type ACS480-04-...	Derating factor		
	≤ 4 kHz	8 kHz	12 kHz
3-phase $U_N = 400 \text{ V}$			
02A7-4	1.0	0.65	0.48
03A4-4	1.0	0.65	0.48

IEC type ACS480-04-...	Derating factor		
	≤ 4 kHz	8 kHz	12 kHz
04A1-4	1.0	0.65	0.48
05A7-4	1.0	0.65	0.48
07A3-4	1.0	0.65	0.48
09A5-4	1.0	0.65	0.48
12A7-4	1.0	0.68	0.51
018A-4	1.0	0.68	0.51
026A-4	1.0	0.67	0.51
033A-4	1.0	0.65	0.49
039A-4	1.0	0.65	0.49
046A-4	1.0	0.66	0.49
050A-4	1.0	0.66	0.49

UL (NEC) type ACS480-04-...	Derating factor		
	≤ 4 kHz	8 kHz	12 kHz
3-phase $U_N = 480$ V			
02A1-4	1.0	0.65	0.48
03A0-4	1.0	0.65	0.48
03A5-4	1.0	0.65	0.48
04A8-4	1.0	0.65	0.48
06A0-4	1.0	0.65	0.48
07A6-4	1.0	0.65	0.48
011A-4	1.0	0.68	0.51
014A-4	1.0	0.68	0.51
021A-4	1.0	0.67	0.51
027A-4	1.0	0.65	0.49
034A-4	1.0	0.65	0.49
042A-4	1.0	0.66	0.49

■ Altitude derating

400/480 V units: In altitudes 1000...4000 m (3281...13123 ft) above sea level, the derating is 1% for every 100 m (328 ft). In addition:

- A maximum altitude of 4000 m (13123 ft) is permitted for these earthing systems: neutral-grounded TN and TT systems and non-corner grounded IT systems. A maximum altitude of 2000 m (6562 ft) is permitted for these earthing systems: corner-grounded TN, TT and IT systems.
- Above 2000 m (6562 ft), the maximum permitted voltage for the relay output RO1 decreases. At 4000 m (13123 ft), it is 30 V.
- Above 2000 m (6562 ft), the maximum permitted potential difference between the adjacent relays of the BREL-01 relay extension module (option +L511) decreases. At 4000 m (13123 ft), it is 30 V.

To calculate the output current, multiply the current in the rating table with the derating factor k , which for x meters ($1000 \text{ m} \leq x \leq 4000 \text{ m}$) or feet ($3281 \text{ ft} \leq x \leq 13123 \text{ ft}$) is:

$$k = 1 - \frac{x - 1000 \text{ m}}{10000 \text{ m}}$$

$$k = 1 - \frac{x - 3281 \text{ ft}}{32810 \text{ ft}}$$

Fuses

The tables list the fuses for protection against short circuits in the input power cable or drive. Either fuse type can be used if it operates rapidly enough. The operating time depends on the supply network impedance, and the cross-sectional area and length of the supply cable.

Do not use fuses with a higher current rating than that given in the table. You can use fuses from other manufacturers, if they meet the ratings, and if the melting curve of the fuse does not exceed the melting curve of the fuse mentioned in the table.

■ gG fuses (IEC)

Make sure that the operating time of the fuse is less than 0.5 seconds. Obey the local regulations.

IEC type ACS480-04-...	Drive input current	Min. short-circuit current ¹⁾	Fuses				
			Nom. current	I ² t	Voltage rating	ABB type	IEC 60269 size
	A	A	A	A ² s	V		
3-phase $U_N = 400 \text{ V}$							
02A7-4	4.2	48	6	110	500	OFAF000H6	000
03A4-4	5.3	48	6	110	500	OFAF000H6	000
04A1-4	6.4	80	10	360	500	OFAF000H10	000
05A7-4	9.0	80	10	360	500	OFAF000H10	000
07A3-4	11.5	128	16	740	500	OFAF000H16	000
09A5-4	15.0	128	16	740	500	OFAF000H16	000
12A7-4	20.2	200	25	2500	500	OFAF000H25	000
018A-4	27.2	256	32	4500	500	OFAF000H32	000
026A-4	40.0	400	50	15500	500	OFAF000H50	000
033A-4	45.0	504	63	20000	500	OFAF000H63	000
039A-4	50.0	640	80	36000	500	OFAF000H80	000
046A-4	56.0	800	100	65000	500	OFAF000H100	000
050A-4	60.0	800	100	65000	500	OFAF000H100	000

¹⁾ Minimum allowed short-circuit current of the electrical power network

■ gR fuses (IEC)

IEC type ACS480-04-...	Drive input current	Min. short-circuit current ¹⁾	Fuses				
			Nominal current	I ² t	Voltage rating	Bussmann type	IEC 60269 size
	A	A	A	A ² s	V		
3-phase $U_N = 400 \text{ V}$							
02A7-4	4.2	48	25	125	690	170M2694	00

IEC type ACS480-04-...	Drive in- put cur- rent	Min. short- circuit cur- rent ¹⁾	Fuses				
			Nominal current	I^2t	Voltage rating	Bussmann type	IEC 60269 size
			A	A ² s	V		
03A4-4	5.3	48	25	125	690	170M2694	00
04A1-4	6.4	80	32	275	690	170M2695	00
05A7-4	9.0	80	32	275	690	170M2695	00
07A3-4	11.5	128	40	490	690	170M2696	00
09A5-4	15.0	128	40	490	690	170M2696	00
12A7-4	20.2	200	50	1000	690	170M2697	00
018A-4	27.2	256	63	1800	690	170M2698	00
026A-4	40.0	400	80	3600	690	170M2699	00
033A-4	45.0	504	100	6650	690	170M2700	00
039A-4	50.0	640	125	12000	690	170M2701	00
046A-4	56.0	800	160	22500	690	170M2702	00
050A-4	60.0	800	160	22500	690	170M2702	00

¹⁾ Minimum allowed short-circuit current of the electrical power network

■ T fuses (UL(NEC))

UL (NEC) type ACS480-04-...	Drive in- put cur- rent	Min. short- circuit cur- rent ¹⁾	Fuses				
			Nominal current	Voltage rating	Bussmann/ Edison type	UL class	Max. group fuse ²⁾
			A	V			A
3-phase $U_N = 480$ V							
02A1-4	4.2	48	6	600	JJS/TJS6	T	25
03A0-4	5.3	48	6	600	JJS/TJS6	T	25
03A5-4	6.4	80	10	600	JJS/TJS10	T	25
04A8-4	9.0	80	10	600	JJS/TJS10	T	25
06A0-4	11.5	128	20	600	JJS/TJS20	T	25
07A6-4	15.0	128	20	600	JJS/TJS20	T	25
011A-4	20.2	200	25	600	JJS/TJS25	T	30
014A-4	27.2	256	35	600	JJS/TJS35	T	40
021A-4	40.0	400	40	600	JJS/TJS40	T	40
027A-4	45.0	504	60	600	JJS/TJS60	T	100
034A-4	50.0	640	80	600	JJS/TJS80	T	100
042A-4	60.0	800	100	600	JJS/TJS100	T	100

¹⁾ Minimum allowed short-circuit current of the electrical power network

²⁾ Branch circuit short-circuit protection for group installation by fuses: Suitable for motor group installation on a circuit that is capable of delivering no more than 65000 rms symmetrical amperes, 480 V maximum, when protected by class T fuses. The same fuse size is specified for several consecutive drive types. This is possible since the physical structure of the drive types is identical.

Alternate short-circuit protection

■ Miniature circuit breakers (IEC)

Note: Miniature circuit breakers with or without fuses have not been evaluated for use as short circuit protection in North America (UL) environments.

The protective characteristics of the circuit breakers depend on the type, construction and settings of the breakers. There are also limitations pertaining to the short-circuit capacity of the supply network. Your local ABB representative can help you in selecting the breaker type when the supply network characteristics are known.



WARNING!

Due to the inherent operating principle and construction of circuit breakers, independent of the manufacturer, hot ionized gases can escape from the breaker enclosure in case of a short-circuit. To ensure safe use, pay special attention to the installation and placement of the breakers. Obey the manufacturer's instructions.

You can use the circuit breakers specified by ABB. You can also use other circuit breakers with the drive if they provide the same electrical characteristics. ABB does not assume any liability whatsoever for the correct function and protection of the circuit breakers not specified by ABB. Furthermore, if the specifications given by ABB are not obeyed, the drive can experience problems the warranty does not cover.

IEC type ACS480-04-...	Frame	ABB miniature circuit breaker	Network SC ¹⁾
		Type	kA
3-phase $U_N = 400\text{ V}$			
02A7-4	R1	S 203P-B 6	5
03A4-4	R1	S 203P-B 6	5
04A1-4	R1	S 203P-B 8	5
05A7-4	R1	S 203P-B 10	5
07A3-4	R1	S 203P-B 16	5
09A5-4	R1	S 203P-B 16	5
12A7-4	R2	S 203P-B 25	5
018A-4	R3	S 203P-B 32	5
026A-4	R3	S 203P-B 50	5
033A-4	R4	S 203P-B 63	5
039A-4	R4	S 803S-B 80	5
046A-4	R4	S 803-B 100	5
050A-4	R4	S 803-B 100	5

¹⁾ Maximum allowed rated conditional short-circuit current (IEC 61800-5-1) of the electrical power network.

■ Manual self-protected combination motor controller – Type E USA (UL (NEC))

You can use the ABB Type E manual motor protectors (MMP) MS132 & S1-M3-25, MS165-xx and MS5100-100 as an alternate to the recommended fuses as a means of branch circuit protection. This is in accordance with the National Electrical Code (NEC). When the correct ABB Type E manual motor protector is selected from the table and used for branch circuit protection, the drive is suitable for use in a circuit capable of delivering no more than 65 kA RMS symmetrical amperes at the maximum rated voltage of the drive. See the table below for the appropriate MMP types and minimum enclosure volume of IP20 / UL open type drive mounted in an enclosure.

Note: The UL Listing of drive and MMP combinations applies only to drives that are mounted in appropriately sized metal enclosures that are capable of containing any drive component failure. Wall-mounted drives with UL type 1 kits (optional) are not covered by the UL combination listing of drives with MMPs.



WARNING! Use fuses for the short-circuit protection of a wall-mounted drive with the UL type 1 kit (optional). Serious injury, fire, or damage to equipment can result from the use of MMPs instead of fuses.

UL (NEC) type ACS480-04-...	Frame	MMP type 1) 2) 3)	Minimum enclosure volume 4)	
			dm ³	cu in
3-phase $U_N = 480$ V				
02A1-4	R1	MS132-6.3 & S1-M3-25 5)	24.3	1482
03A0-4	R1	MS132-6.3 & S1-M3-25 5)	24.3	1482
03A5-4	R1	MS132-10 & S1-M3-25 5)	24.3	1482
04A8-4	R1	MS132-10 & S1-M3-25 5)	24.3	1482
06A0-4	R1	MS165-16	24.3	1482
07A6-4	R1	MS165-16	24.3	1482
011A-4	R2	MS165-20	24.3	1482
014A-4	R3	MS165-32	24.3	1482
021A-4	R3	MS165-42	24.3	1482
027A-4	R4	MS165-54	75.0	4577
034A-4	R4	MS165-65	75.0	4577
042A-4	R4	MS5100-100 / MS165-80	75.0	4577

1) All manual motor protectors listed are Type E self-protected up to 65 kA. See the ABB publication 2CDC131085M0201 – Manual Motor Starters – North American Applications for complete technical data on the ABB Type E manual motor protectors. In order for these manual motor protectors to be used for branch circuit protection, they must be UL listed Type E manual motor protectors, otherwise they can be used only as an At Motor Disconnect. "At Motor Disconnect" is a disconnect just ahead of the motor on the load side of the panel.

2) 480Y/277 V delta systems only: Short-circuit protective devices with slash voltage ratings (e.g. 480Y/277 V AC) can be applied only in solidly grounded networks where the voltage from line-to-ground does not exceed the lower of the two ratings (e.g. 277 V AC), and the voltage from line-to-line does not exceed the higher of the two ratings (e.g. 480 V AC). The lower rating represents the device's interrupting capability per pole.

3) Manual motor protectors may require adjusting the trip limit from the factory setting at or above the drive input Amps to avoid nuisance tripping. If the manual motor protector is set to the maximum current trip level and nuisance tripping is

occurring, select the next size MMP. (MS132-10 is the highest size in the MS132 frame size to meet Type E at 65 kA; the next size up is MS165-16.)

- 4) For all drives, the enclosure must be sized to accommodate the specific thermal considerations of the application as well as provide free space for cooling. Refer to the technical data. For UL only: The minimum enclosure volume is specified in the UL listing when applied with the ABB Type E MMP shown in the table. Fuses must be used for wall-mounted drives installed with a UL Type 1 kit.
- 5) Requires the use of the S1-M3-25 line side feeder terminal with the manual motor protector to meet Type E self-protection class.

Dimensions and weights

Frame	Dimensions and weights (IP20 / UL type open)															
	H1		H2		H3		W		D		M1		M2		Weight	
	mm	in	mm	in	mm	in	mm	in	mm	in	mm	in	mm	in	kg	lb
R1	205	8.1	223	8.8	170	6.7	73	2.9	208	8.2	50	1.97	191	7.52	1.7	3.6
R2	205	8.1	223	8.8	170	6.7	97	3.9	208	8.2	75	2.95	191	7.52	2.2	4.9
R3	205	8.1	220	8.7	170	6.7	172	6.8	208	8.2	148	5.83	191	7.52	2.5	5.6
R4	205	8.1	240	9.5	170	6.7	262	10.3	213	8.2	234	9.21	191	7.52	5.6	12.4

Frame	Dimensions and weights (UL type 1 kit installed)															
	H1		H2		H3		W		D		M1		M2		Weight ¹⁾	
	mm	in	mm	in	mm	in	mm	in	mm	in	mm	in	mm	in	kg	lb
R1	205	8.1	293	11.6	247	9.8	73	2.9	208	8.2	50	1.97	191	7.52	0.4	1.0
R2	205	8.1	293	11.6	247	9.8	111	4.4	208	8.2	75	2.95	191	7.52	0.5	1.1
R3	205	8.1	329	13.0	261	10.3	186	7.4	208	8.2	148	5.83	191	7.52	0.7	1.6
R4	205	8.1	391	15.4	312	12.3	284	11.2	213	8.4	234	9.21	191	7.52	1.3	2.7

¹⁾ Additional weight of the UL type 1 kit.

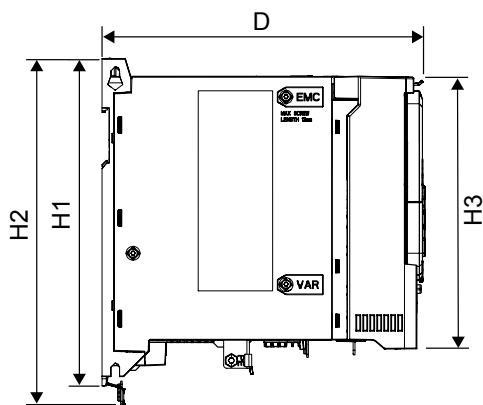

Symbols

- H1** Height back
- H2** Height back
- H3** Height front
- W** Width of the base unit
- D** Depth
- M1** Mounting hole distance 1
- M2** Mounting hole distance 2

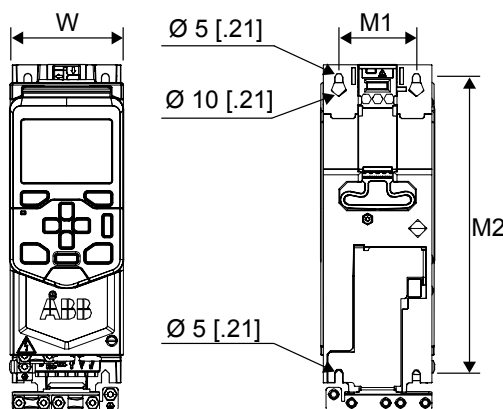

Free space requirements

Frame	Free space requirement					
	Above		Below		On the sides ¹⁾	
	mm	in	mm	in	mm	in
All	50	2	75	3	0	0

¹⁾ If you plan to install a side-mounted option module to the drive, take the extra width needed on the right into account.

Losses, cooling data and noise

The air flow direction is from bottom to top.

The tables below specify the heat dissipation in the main circuit at nominal load and in the control circuit with minimum load (I/O and panel not in use) and maximum load (all digital inputs in the on state and the panel, fieldbus and fan in use). The total heat dissipation is the sum of the heat dissipation in the main and control circuits.

108 Technical data

IEC type ACS480-04-...	Heat dissipation				Air flow		Noise
	Main circuit at rated current	Control circuit min.	Control circuit max.	Main and control circuit max.	m ³ /h	ft ³ /min	
	W	W	W	W			dB(A)
3-phase $U_N = 400$ V							
02A7-4	35	9	20	55	57	33	63
03A4-4	42	9	20	62	57	33	63
04A1-4	50	9	20	70	57	33	63
05A7-4	68	9	20	88	57	33	63
07A3-4	88	9	20	108	57	33	63
09A5-4	115	9	20	135	57	33	63
12A7-4	158	9	20	178	63	37	59
018A-4	208	11	22	230	128	75	66
026A-4	322	11	22	344	128	75	66
033A-4	435	18	30	465	150	88	69
039A-4	537	18	30	566	150	88	69
046A-4	638	18	30	668	150	88	69
050A-4	638	18	30	668	150	88	69

UL (NEC) type ACS480-04-...	Heat dissipation								Air flow		Noise
	Main circuit at rated current		Control circuit min.		Control circuit max.		Main and control circuit max.		m ³ /h	ft ³ /min	
	W	BTU/h	W	BTU/h	W	BTU/h	W	BTU/h			dB(A)
3-phase $U_N = 480$ V											
02A1-4	35	121	9	29	20	69	55	189	57	33	63
03A0-4	42	145	9	29	20	69	62	213	57	33	63
03A5-4	50	172	9	29	20	69	70	240	57	33	63
04A8-4	68	233	9	29	20	69	88	302	57	33	63
06A0-4	88	299	9	29	20	69	108	368	57	33	63
07A6-4	115	392	9	29	20	69	135	461	57	33	63
011A-4	158	540	9	29	20	69	178	609	63	37	59
014A-4	208	709	11	36	22	75	230	784	128	75	66
021A-4	322	1098	11	36	22	75	344	1174	128	75	66
027A-4	435	1486	18	62	30	102	465	1587	150	88	69
034A-4	537	1832	18	62	30	102	566	1934	150	88	69
042A-4	638	2179	18	62	30	102	668	2281	150	88	69

Terminal data for the power cables

IEC type ACS480-04-...	U1, V1, W1, T1/U, T2V, T3/W, R-, R+/ UDC+			PE
	Min (solid/stranded)	Max (solid/stranded)	Torque	Torque
	mm ²	mm ²	N·m	N·m
3-phase $U_N = 400$ V				
02A7-4	0.2/0.2	6/6	0.5...0.6	1.2
03A4-4	0.2/0.2	6/6	0.5...0.6	1.2
04A1-4	0.2/0.2	6/6	0.5...0.6	1.2
05A7-4	0.2/0.2	6/6	0.5...0.6	1.2
07A3-4	0.2/0.2	6/6	0.5...0.6	1.2
09A5-4	0.2/0.2	6/6	0.5...0.6	1.2
12A7-4	0.2/0.2	6/6	0.5...0.6	1.2
018A-4	0.5/0.5	16/16	1.2...1.5	1.2
026A-4	0.5/0.5	16/16	1.2...1.5	1.2
033A-4	0.5/0.5	25/35	2.5...3.7	2.9
039A-4	0.5/0.5	25/35	2.5...3.7	2.9
046A-4	0.5/0.5	25/35	2.5...3.7	2.9
050A-4	0.5/0.5	25/35	2.5...3.7	2.9

UL (NEC) type ACS480-04-...	U1, V1, W1, T1/U, T2V, T3/W, R-, R+/ UDC+			PE
	Min (solid/stranded)	Max (solid/stranded)	Torque	Torque
	AWG	AWG	lbf·in	lbf·in
3-phase $U_N = 480$ V				
02A1-4	18	10	5	10.6
03A0-4	18	10	5	10.6
03A5-4	18	10	5	10.6
04A8-4	18	10	5	10.6
06A0-4	18	10	5	10.6
07A6-4	18	10	5	10.6
011A-4	18	10	5	10.6
014A-4	20	6	11...13	10.6
021A-4	20	6	11...13	10.6
027A-4	20	2	22...32	25.7
034A-4	20	2	22...32	25.7
042A-4	20	2	22...32	25.7

Typical power cable sizes

These are the typical power cable (and conductor) sizes at the nominal drive current.

IEC type ACS480-04-...	Cable conductor sizes (mm ²) ¹⁾	Frame
3-phase $U_N = 400$ V		
02A7-4	3×1.5 + 1.5	R1
03A4-4	3×1.5 + 1.5	R1
04A1-4	3×1.5 + 1.5	R1
05A7-4	3×1.5 + 1.5	R1
07A3-4	3×1.5 + 1.5	R1
09A5-4	3×2.5 + 2.5	R1
12A7-4	3×2.5 + 2.5	R2
018A-4	3×6 + 6	R3
026A-4	3×6 + 6	R3
033A-4	3×10 + 10	R4
039A-4	3×16 + 16	R4
046A-4	3×25 + 16	R4
050A-4	3×25 + 16	R4

¹⁾ Size of typical power cable (symmetrical, shielded, three-phase copper cable). Note that for the input power connection, you may have to use two separate PE conductors (IEC 61800-5-1).

UL (NEC) type ACS480-04-...	Wire size, Cu (AWG)	Frame
3-phase $U_N = 480$ V		
02A1-4	16	R1
03A0-4	16	R1
03A5-4	16	R1
04A8-4	16	R1
06A0-4	16	R1
07A6-4	14	R1
011A-4	14	R2
014A-4	10	R3
021A-4	10	R3
027A-4	8	R4
034A-4	6	R4
042A-4	4	R4

Terminal data for the control cables

This table shows the control cable terminal data of the standard drive variant, that is, the base unit with RIIO-01 I/O & EIA-485 module.

Wire size		Torque	
mm ²	AWG	N·m	lbf·in
0.14...1.5	26...16	0.5...0.6	4.4...5.3

External EMC filters

The table shows the external EMC filters and which EMC categories are met with the filters. The drive with internal EMC filter meets the C2 category. It is in use as standard in all IEC drive types. See also [EMC compatibility and motor cable length](#) and [EMC compliance \(IEC/EN 61800-3:2004 + A2012\)](#) (page 117).

IEC type ACS480-04-...	EMC filter type		Category		
	ABB type code	Schaffner order code	C1	C2	C3
3-phase $U_N = 400$ V					
02A7-4	RFI-32	FN 3268-16-44	x	x	x
03A4-4	RFI-32	FN 3268-16-44	x	x	x
04A1-4	RFI-32	FN 3268-16-44	x	x	x
05A7-4	RFI-32	FN 3268-16-44	x	x	x
07A3-4	RFI-32	FN 3268-16-44	x	x	x
09A5-4	RFI-32	FN 3268-16-44	x	x	x
12A7-4	RFI-32	FN 3268-16-44	x	x	x
018A-4	RFI-32	FN 3268-30-33	x	x	x
026A-4	RFI-33	FN 3268-30-33	x	x	x
033A-4	RFI-34	FN 3258-100-35	x	x	x
039A-4	RFI-34	FN 3258-100-35	x	x	x
046A-4	RFI-34	FN 3258-100-35	x	x	x
050A-4	RFI-34	FN 3258-100-35	x	x	x

UL (NEC) type ACS480-04-...	EMC filter type		Category		
	ABB type code	Schaffner order code	C1	C2	C3
3-phase $U_N = 480$ V					
02A1-4	RFI-32	FN 3268-16-44	x	x	x
03A0-4	RFI-32	FN 3268-16-44	x	x	x
03A5-4	RFI-32	FN 3268-16-44	x	x	x
04A8-4	RFI-32	FN 3268-16-44	x	x	x
06A0-4	RFI-32	FN 3268-16-44	x	x	x
07A6-4	RFI-32	FN 3268-16-44	x	x	x
011A-4	RFI-32	FN 3268-16-44	x	x	x
014A-4	RFI-32	FN 3268-30-33	x	x	x
021A-4	RFI-33	FN 3268-30-33	x	x	x
027A-4	RFI-34	FN 3258-100-35	x	x	x
034A-4	RFI-34	FN 3258-100-35	x	x	x
042A-4	RFI-34	FN 3258-100-35	x	x	x

If you use an external EMC filter, you must disconnect the internal EMC filter. Refer to the electrical installation instructions.

Electrical power network specification

Voltage (U1)	ACS480-04-xxxx-4 drives: Input voltage range 3-phase 380...480 V AC +10%...-15 %. This is indicated in the type designation label as typical input voltage levels 3-phase 400/480 V AC.		
Network type	Public low voltage networks. Symmetrically grounded TN-S system, IT (ungrounded), corner-grounded delta. Consult ABB before connecting to other systems (eg, TT, or midpoint grounded delta).		
Rated conditional short-circuit current (IEC 61800-5-1)	65 kA when protected by fuses given in the fuse tables. Note: If the short-circuit current is more than specified in the table below, it is necessary to use a mains choke.		
Short-circuit current protection (UL 61800-5-1, CSA C22.2 No. 274-13)	US and Canada: The drive is suitable for use on a circuit capable of delivering not more than 100 kA symmetrical amperes (rms) at 480 V maximum when protected by fuses given in the fuse table. Note: If the short-circuit current is more than specified in the table below, it is necessary to use a mains choke.		
Mains choke	Use a mains choke if the short-circuit capacity of the network at the drive terminals is more than in the table:		
	Frame / Voltage rating	R1, R2	R3, R4
	3-phase 380...480 V	>5.0 kA	>10 kA
	You can use one choke for several drives if the short-circuit capacity at the drive terminals is reduced to the value in the table.		
Frequency (f1)	47 to 63 Hz, maximum rate of change 2%/s		
Imbalance	Max. $\pm 3\%$ of nominal phase to phase input voltage		
Fundamental power factor (cos phi)	0.98 (at nominal load)		

Motor connection data

Motor type	Asynchronous AC induction motors, permanent magnet synchronous motors or ABB synchronous reluctance motors (SynRM motors)
Voltage (U2)	0 to U1, 3-phase symmetrical
Short-circuit protection (IEC 61800-5-1, UL 61800-5-1)	The motor output is short-circuit proof by IEC 61800-5-1 and UL 61800-5-1.
Frequency (f2)	0...500 Hz
Frequency resolution	0.01 Hz
Current	See the rating information.
Switching frequency	2, 4, 8, or 12 kHz

■ Motor cable length

Operational functionality and motor cable length

The drive is designed to operate with optimum performance with the following maximum motor cable lengths. The values are valid for 4 kHz switching frequency.

Frame	Maximum motor cable length	
	m	ft
Standard drive, without external options		
R1, R2	150	492
R3, R4	150	492
With external output chokes		
R1...R3	250	820
R4	200	656

Note: In multimotor systems, the calculated sum of all motor cable lengths must not exceed the maximum motor cable length given in the table.

EMC compatibility and motor cable length

To comply with the EMC limits in the European EMC Directive (standard IEC/EN 61800-3), do not exceed these maximum motor cable lengths. They are valid for 4 kHz switching frequency.

Frame	Maximum motor cable length, 4 kHz					
	C1 ¹⁾		C2		C3	
	m	ft	m	ft	m	ft
With internal EMC filter						
3-phase 380...480 V						
R1	-	-	10	30	30	100
R2	-	-	10	30	20	66
R3	-	-	10	30	30	100
R4	-	-	10	30	30	100
With optional external EMC filter						
3-phase 208...240 V/380...480 V						
R1	30	100	50	150	50	150
R2	30	100	50	150	50	150
R3	30	100	50	150	50	150
R4	30	100	30	100	50	150

¹⁾ Category C1 with conducted emissions only. Radiated emissions are not compatible when measured with the standard emission measurement setup and must be measured on cabinet and machine installations for each case.

Note:

- For 3-phase 380...400 V drives, the maximum motor cable lengths are according to C3 in the above table with an internal EMC filter.

Brake resistor connection data

Short-circuit protection (IEC 61800-5-1, IEC 60439-1, UL 61800-5-1)	The brake resistor output is conditionally short-circuit proof by IEC/EN 61800-5-1 and UL 61800-5-1. Rated conditional short-circuit current is as defined in IEC 60439-1.
--	---

Control connection data

The data is valid for the standard drive variant (base unit equipped with the I/O & EIA-485 module (RIIO-01)).

Analog inputs (AI1, AI2)	Voltage signal, single-ended	0...10 V DC (10% overrange, 11 V DC max.) $R_{in} = 221.6 \text{ kohm}$
	Current signal, single-ended	0...20 mA (10% overrange, 22 mA max.) $R_{in} = 137 \text{ ohm}$
	Inaccuracy	$\leq 1.0\%$, of full scale
	Overvoltage protection	up to 30 V DC
	Potentiometer reference value	10 V DC $\pm 1\%$, max. load current 10 mA
Analog output (AO1, AO2)	Current output mode	0...20 mA (10% overrange, 22 mA max.) into 500 ohm load (AO2 only supports output current)
	Voltage output mode	0...10 V DC (10% overrange, 11 V DC max.) into 200 kohm minimum load (resistive)
	Inaccuracy	$\leq 2\%$, of full scale
Auxiliary power output or input (+24V, DGND)	As output	+24 V DC $\pm 10\%$, max. 250 mA (from base unit and/or RIIO-01 module)
	As input (optional BAPO-01 module required)	+24 V DC $\pm 10\%$, max. 1000 mA (incl. internal fan load)
Digital inputs (DI1...DI6)	Voltage	12...24 V DC (int. or ext. supply) Max. 30 V DC.
	Type	PNP and NPN
	Input impedance	$R_{in} = 2 \text{ kohm}$
DI5 (digital or frequency input)	Voltage	12...24 V DC (int. or ext. supply) max. 30 V DC.
	Type	PNP and NPN
	Input impedance	$R_{in} = 2 \text{ kohm}$
	Max. frequency	10...16 kHz
Relay output (RO1, RO2, RO3)	Type	1 form C (NO + NC)
	Max. switching voltage	250 V AC / 30 V DC
	Max. switching current	2 A (non inductive)
STO interface	Refer to The Safe torque off function (page 147)	
EIA-485 embedded field-bus (A+, B-, DGND)	Connector pitch 5 mm, wire size 2.5 mm ² Physical layer: RS-485 Cable type: Shielded twisted pair cable with twisted pair for data and a wire or pair for signal ground, nominal impedance 100...165 ohm, for example Belden 9842 Transmission rate: 9.6...115.2 kbit/s Termination by switch	

Efficiency

Approximately 98% at nominal power level.

Protection classes

Degree of protection (IEC/EN 60529)	IP20. The drive must be installed in a cabinet to fulfill the requirements for shielding from contact.
Enclosure types (UL 61800-5-1)	UL Open Type. For indoor use only. UL type 1 kit is available as an option.
Overvoltage category (IEC 60664-1)	III
Protective classes (IEC/EN 61800-5-1)	I

Ambient conditions

Environmental limits for the drive are given below. The drive is to be used in a heated indoor controlled environment.

Requirement	Operation installed for stationary use	Storage in the protective package	Transportation in the protective package
Installation site altitude	400/480 V units: 0...4000 m above sea level (with derating above 1000 m) See <i>Output derating</i> (page 98).	-	-
Air temperature	-10...+60 °C (14...140 °F). Output is derated above 50 °C (122 °F). See <i>Output derating</i> (page 98). No frost allowed.	-40...+70 °C ±2% (-40...+158 °F ±2%)	-40...+70 °C ±2% (-40...+158 °F ±2%)
Relative humidity	5...95% No condensation allowed. Maximum allowed relative humidity is 60% in the presence of corrosive gases.	Max. 95%	Max. 95%
Contamination levels (IEC 60721-3-x)	IEC 60721-3-3: 2002	IEC 60721-3-1: 1997	IEC 60721-3-2: 1997
- Chemical gases	Class 3C2	Class 1C2	Class 2C2
- Solid particles	Class 3S2. No conductive dust allowed.	Class 1S3. (packing must support this, otherwise 1S2)	Class 2S2
Pollution degree (IEC/EN 61800-5-1)	Pollution degree 2	-	-
Sinusoidal vibration (IEC 60068-2-6, Test Fc 2007-12)	frequency 10...150 Hz; amplitude ±0.075 mm (0.003 in), 10...57,56 Hz; constant peak acceleration 10 m/s ² (33 ft/s ²), 57,56...150 Hz; sweep: 1 oct/min; 10 sweep cycles in each axis with STO active; uncertainty ±5.0%; normal mounting	-	-

Requirement	Operation installed for stationary use	Storage in the protective package	Transportation in the protective package
Shock/(IEC 60068-2-27, ISTA 1A)	Not allowed	According to ISTA 1A. Max. 100 m/s ² (330 ft/s ²), 11 ms.	According to ISTA 1A. Max. 100 m/s ² (330 ft/s ²), 11 ms.
Free fall	-	76 cm (30 in)	76 cm (30 in)

Materials

Drive enclosure	Hot-dip zinc coated steel sheet 1.5 mm (0.06 in). Extruded aluminum AlSi. PC/ABS 2 mm (0.08 in), PC+10%GF 2.5...3 mm (0.10...0.12 in) and PA66+25%GF 1.5 mm (0.06 in), all in color NCS 1502-Y (RAL 9002 / PMS 420 C)
Package	Corrugated cardboard

Disposal

The main parts of the drive can be recycled to preserve natural resources and energy. Product parts and materials should be dismantled and separated.

Generally all metals, such as steel, aluminum, copper and its alloys, and precious metals can be recycled as material. Plastics, rubber, cardboard and other packaging material can be used in energy recovery. Printed circuit boards and large electrolytic capacitors need selective treatment according to IEC 62635 guidelines. To aid recycling, plastic parts are marked with an appropriate identification code.









Contact your local ABB distributor for further information on environmental aspects and recycling instructions for professional recyclers. End of life treatment must follow international and local regulations.

Applicable standards

The drive complies with the following standards:

EN ISO 13849-1:2015	Safety of machinery – Safety related parts of the control systems – Part 1: general principles for design
EN ISO 13849-2:2012	Safety of machinery – Safety-related parts of the control systems – Part 2: Validation
EN 60204-1:2006 + A1:2009 + AC:2010	Safety of machinery. Electrical equipment of machines. Part 1: General requirements. Provisions for compliance: The final assembler of the machine is responsible for installing <ul style="list-style-type: none"> • an emergency-stop device • a supply disconnecting device
EN 62061:2005 + AC:2010 + A1:2013 + A2:2015	Safety of machinery – Functional safety of safety-related electrical, electronic and programmable electronic control systems
EN 61800-3:2004 + A1:2012 IEC 61800-3:2004 + A1:2011	Adjustable speed electrical power drive systems. Part 3: EMC requirements and specific test methods
IEC/EN 61800-5-1:2007	Adjustable speed electrical power drive systems – Part 5-1: Safety requirements – Electrical, thermal and energy
ANSI/UL 61800-5-1:2015	UL Standard for adjustable speed electrical power drive systems – Part 5-1: Safety requirements – Electrical, thermal and energy
CSA C22.2 No. 274-13	Adjustable speed drives

Markings

	<p>CE mark Product complies with the applicable European Union legislation. For fulfilling the EMC requirements, see the additional information concerning the drive EMC compliance (IEC/EN 61800-3).</p>
	<p>TÜV Safety Approved mark (functional safety) Product contains Safe Torque Off and possibly other (optional) safety functions which are certified by TÜV according to the relevant functional safety standards. Applicable to drives and inverters; not applicable to supply, brake or DC/DC converter units or modules.</p>
	<p>UL listed mark for USA and Canada Product has been tested and evaluated against the relevant North American standards by the Underwriters Laboratories.</p>
	<p>CSA certification mark for USA and Canada Product has been tested and evaluated against the relevant North American standards by the CSA Group.</p>
	<p>RCM mark Product complies with Australian and New Zealand requirements specific to EMC, telecommunications and electrical safety. For fulfilling the EMC requirements, see the additional information concerning the drive EMC compliance (IEC/EN 61800-3).</p>
	<p>EAC (Eurasian Conformity) mark Product complies with the technical regulations of the Eurasian Customs Union. EAC mark is required in Russia, Belarus and Kazakhstan.</p>
	<p>Electronic Information Products (EIP) green mark The product complies with the <i>People's Republic of China Electronic Industry Standard</i> (SJ/T 11364-2014). The product does not contain toxic and hazardous substances or elements above the maximum concentration values, and it is an environmentally-friendly product which can be recycled.</p>
	<p>WEEE mark At the end of life the product should enter the recycling system at an appropriate collection point and not placed in the normal waste stream.</p>

EMC compliance (IEC/EN 61800-3:2004 + A2012)

■ Definitions

EMC stands for Electromagnetic Compatibility. It is the ability of electrical/electronic equipment to operate without problems within an electromagnetic environment. Likewise, the equipment must not disturb or interfere with any other product or system within its locality.

First environment includes establishments connected to a low-voltage network which supplies buildings used for domestic purposes.

Second environment includes establishments connected to a network not supplying domestic premises.

Drive of category C1: drive of rated voltage less than 1000 V and intended for use in the first environment.

Drive of category C2: drive of rated voltage less than 1000 V and intended to be installed and started up only by a professional when used in the first environment. **Note:** A professional is a person or organization having necessary skills in installing and/or starting up power drive systems, including their EMC aspects.

Drive of category C3: drive of rated voltage less than 1000 V and intended for use in the second environment and not intended for use in the first environment.

Drive of category C4: drive of rated voltage equal to or above 1000 V, or rated current equal to or above 400 A, or intended for use in complex systems in the second environment.

■ Category C1

The drive complies with the conducted emission limits of the standard with the following provisions:

1. The optional EMC filter is selected according to section [External EMC filters \(page 111\)](#), and the filter is installed as specified in the EMC filter manual.
2. The motor and control cables are selected as specified in this manual. The EMC recommendations are obeyed.
3. The maximum motor cable length does not exceed the specified maximum value. See [EMC compatibility and motor cable length \(page 113\)](#).
4. The drive is installed according to the instructions (IEC) given in this manual.

This product can cause radio-frequency interference. In a residential or domestic environment, supplementary mitigation measures may be required in addition to the requirements listed above for the CE compliance.

■ Category C2

This is applicable to drive with an internal EMC C2 filter. The filter is included to all drive types as standard. However, for the UL(NEC) drive types it is not connected at the factory. The user must re-connect it for the category C2 compliance.

The drive complies with the standard with the following provisions:

1. The motor and control cables are selected as specified in this manual. The EMC recommendations are obeyed.
2. The maximum motor cable length does not exceed the specified maximum. See [EMC compatibility and motor cable length \(page 113\)](#).
3. The drive is installed according to the instructions (IEC) given in this manual.

This product can cause radio-frequency interference. In a residential or domestic environment, supplementary mitigation measures may be required in addition to the requirements listed above for the CE compliance.



WARNING!

Do not install a drive with the internal EMC filter connected to an earthing system that it is not suitable for (for example, an IT system). The supply network becomes connected to ground potential through the internal EMC filter capacitors, which can cause danger or damage to the drive.



WARNING!

To prevent radio-frequency interference, do not use a category C2 drive on a low-voltage public network that supplies domestic premises.

■ **Category C3**

Drive has an internal EMC C2 filter as standard. No EMC C3 filter for category C3 is available.

■ **Category C4**

If the provisions in category 2 or 3 are not met, the requirements of the standard can be met as follows:

1. It is ensured that no excessive emission is propagated to neighboring low-voltage networks. In some cases, the inherent suppression in transformers and cables is sufficient. If in doubt, the supply transformer with static screening between the primary and secondary windings can be used.

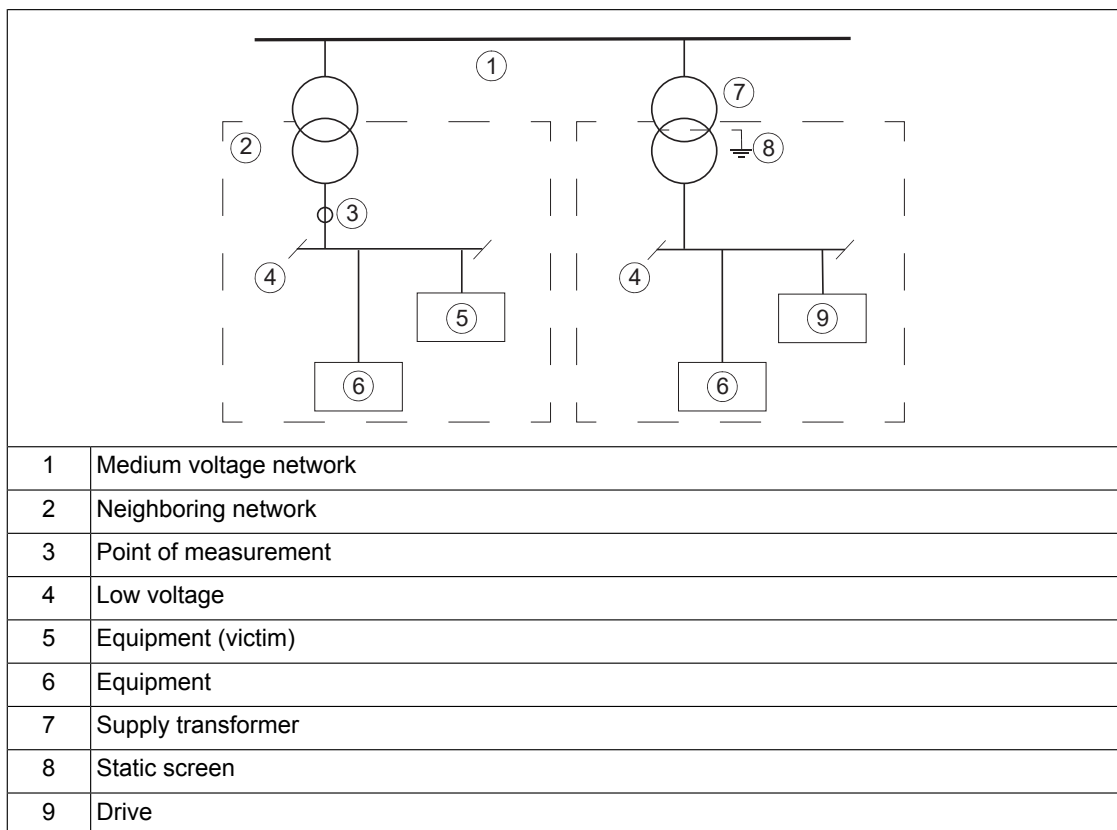

2. An EMC plan for preventing disturbances is drawn up for the installation. A template is available in *Technical guide No. 3 EMC compliant installation and configuration for a power drive system* (3AFE61348280 (English)).
3. The motor and control cables are selected as specified in this manual. For the best EMC performance, the EMC recommendations are obeyed.
4. The drive is installed according to the instructions given in this manual.



WARNING!

Do not install a drive with the internal EMC filter connected to an earthing system that it is not suitable for (for example, an IT system). The supply network becomes

connected to ground potential through the internal EMC filter capacitors, which can cause danger or damage to the drive.



WARNING!

To prevent radio-frequency interference, do not use a category C4 drive on a low-voltage public network that supplies domestic premises.

UL and CSA checklist



WARNING!

Operation of this drive requires detailed installation and operation instructions provided in the hardware and software manuals. The manuals are provided in electronic format in the drive package or on the Internet. Keep the manuals with the drive at all times. Hard copies of the manuals can be ordered through the manufacturer.

- Make sure that the drive type designation label includes the cULus Listed and/or CSA marking.
 - **CAUTION - Risk of electric shock.** After disconnecting the input power, always wait for 5 minutes to let the intermediate circuit capacitors discharge before you start working on the drive, motor or motor cable. Do the steps in section *Electrical safety precautions (page 14)*.
 - Use the drive in a heated, indoor controlled environment. The drive must be installed in clean air according to the enclosure classification. Cooling air must be clean, free from corrosive materials and electrically conductive dust.
 - Use the drive in Pollution degree 2 environment only.
 - The maximum surrounding air temperature is 50 °C (122 °F) at rated output current. The output current must be derated between 50...60 °C (122...140 °F).
 - The drive is suitable for use in a circuit capable of delivering not more than 100000 rms symmetrical amperes, 480 V maximum (480 V drive types), or 240 V maximum (240 V drive types), when protected by the UL fuses specified by ABB. The current rating is based on tests done according to the applicable UL standard. See *T fuses (UL(NEC)) (page 103)*.
 - The drive is suitable for use on a circuit capable of delivering not more than 65000 rms symmetrical amperes, 480Y/277 V maximum (480 V drive types), when protected by Type E combination motor controller specified by ABB. See *Manual self-protected combination motor controller – Type E USA (UL (NEC)) (page 105)*.
 - The cables located within the motor circuit must be copper cables rated for at least 75 °C (167 °F).
 - The input cable must be protected with UL-rated fuses, or the ABB Type E combination motor controllers listed in this manual. The fuses, or the combination motor controllers, provide branch circuit protection in accordance with the National Electrical Code (NEC) and Canadian Electrical Code. For installation in the United States, also obey any other applicable local codes. For installation in Canada, also obey any applicable provincial codes.
Note: Circuit breakers must not be used without fuses in the USA. Contact your local representative for suitable circuit breakers.
 - The opening of the branch-circuit protective device can be an indication that a fault current has been interrupted. To reduce the risk of fire or electric shock, current-carrying
-

parts and other components of the controller should be examined and replaced if damaged. If burnout of the current element of an overload relay occurs, the complete overload relay must be replaced.

- The integral solid state short circuit protection of the drive does not provide branch circuit protection.
- The drive provides motor overload protection. For adjustments, see the firmware manual.
- The drive overvoltage category is III.

Disclaimers

■ Generic disclaimer

The manufacturer shall have no obligation with respect to any product which (i) has been improperly repaired or altered; (ii) has been subjected to misuse, negligence or accident; (iii) has been used in a manner contrary to the manufacturer's instructions; or (iv) has failed as a result of ordinary wear and tear.

■ Cybersecurity disclaimer

This product is designed to be connected to and to communicate information and data via a network interface. It is Customer's sole responsibility to provide and continuously ensure a secure connection between the product and Customer network or any other network (as the case may be). Customer shall establish and maintain any appropriate measures (such as but not limited to the installation of firewalls, application of authentication measures, encryption of data, installation of anti-virus programs, etc) to protect the product, the network, its system and the interface against any kind of security breaches, unauthorized access, interference, intrusion, leakage and/or theft of data or information. ABB and its affiliates are not liable for damages and/or losses related to such security breaches, any unauthorized access, interference, intrusion, leakage and/or theft of data or information.





11

Dimension drawings

Contents of this chapter

The chapter contains the dimension drawings of the drive. The dimensions are in millimeters and inches.

Frame R1

- Frame R1 (front & side) - IP20 / UL type open

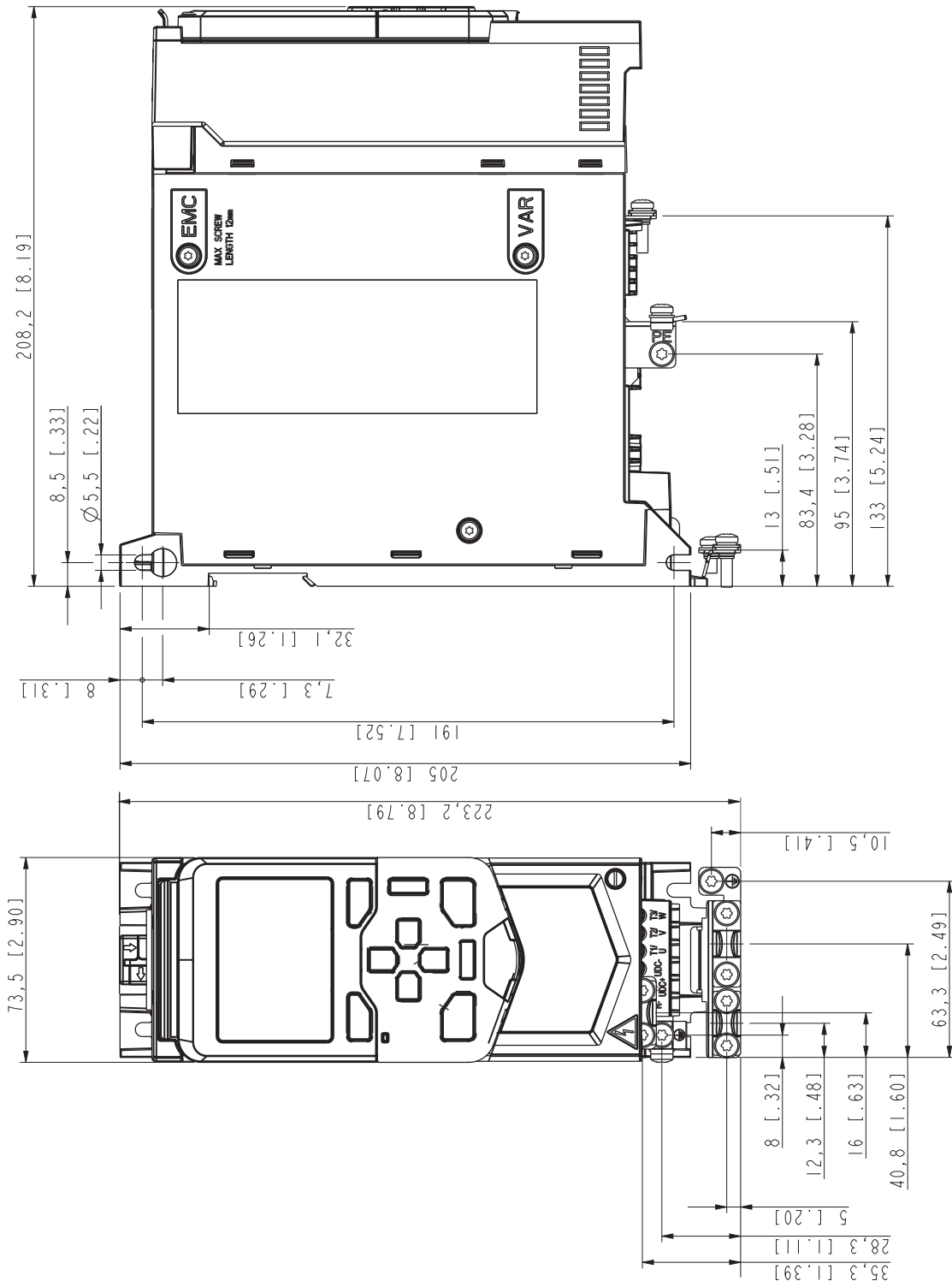

■ Frame R1 (bottom & rear) - IP20 / UL type open

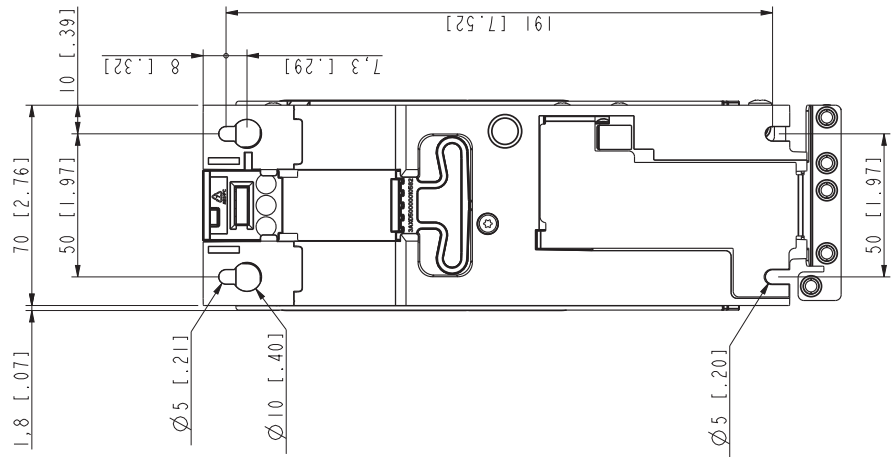
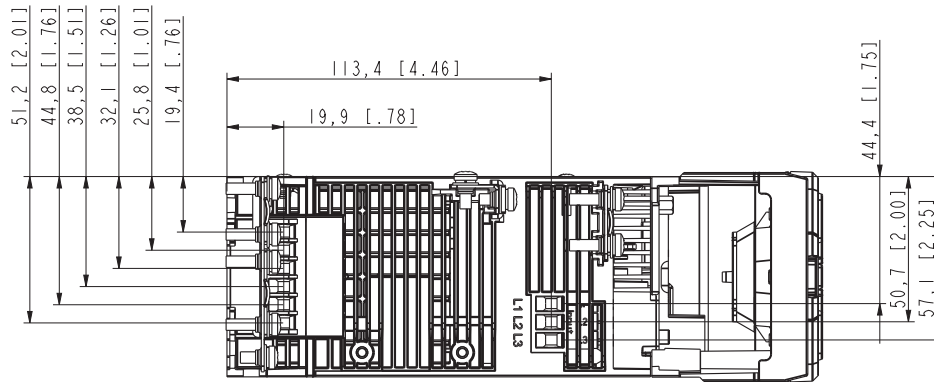

■ Frame R1 (front & side) - UL type 1 kit installed

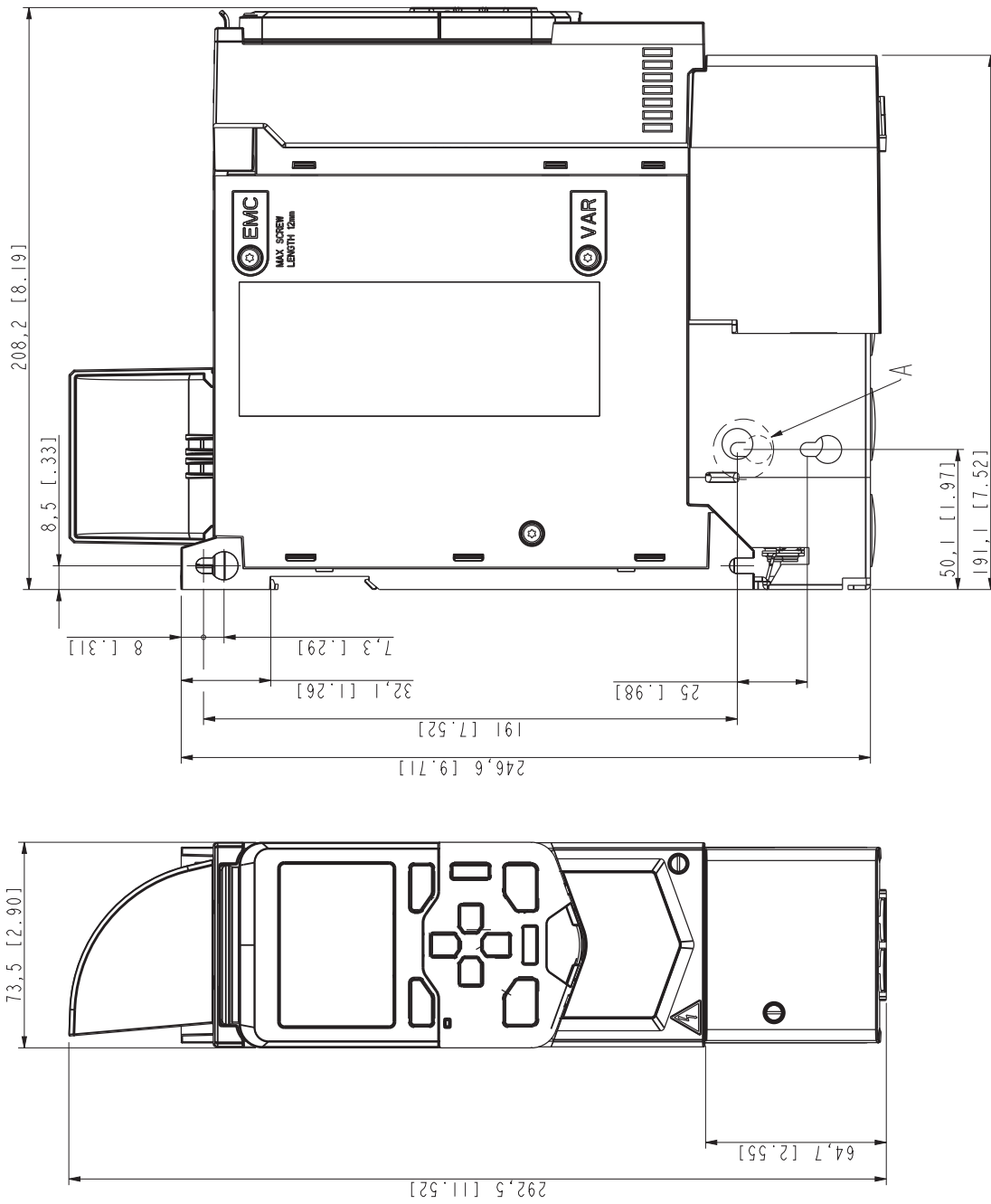

■ Frame R1 (bottom & rear) - UL type 1 kit installed

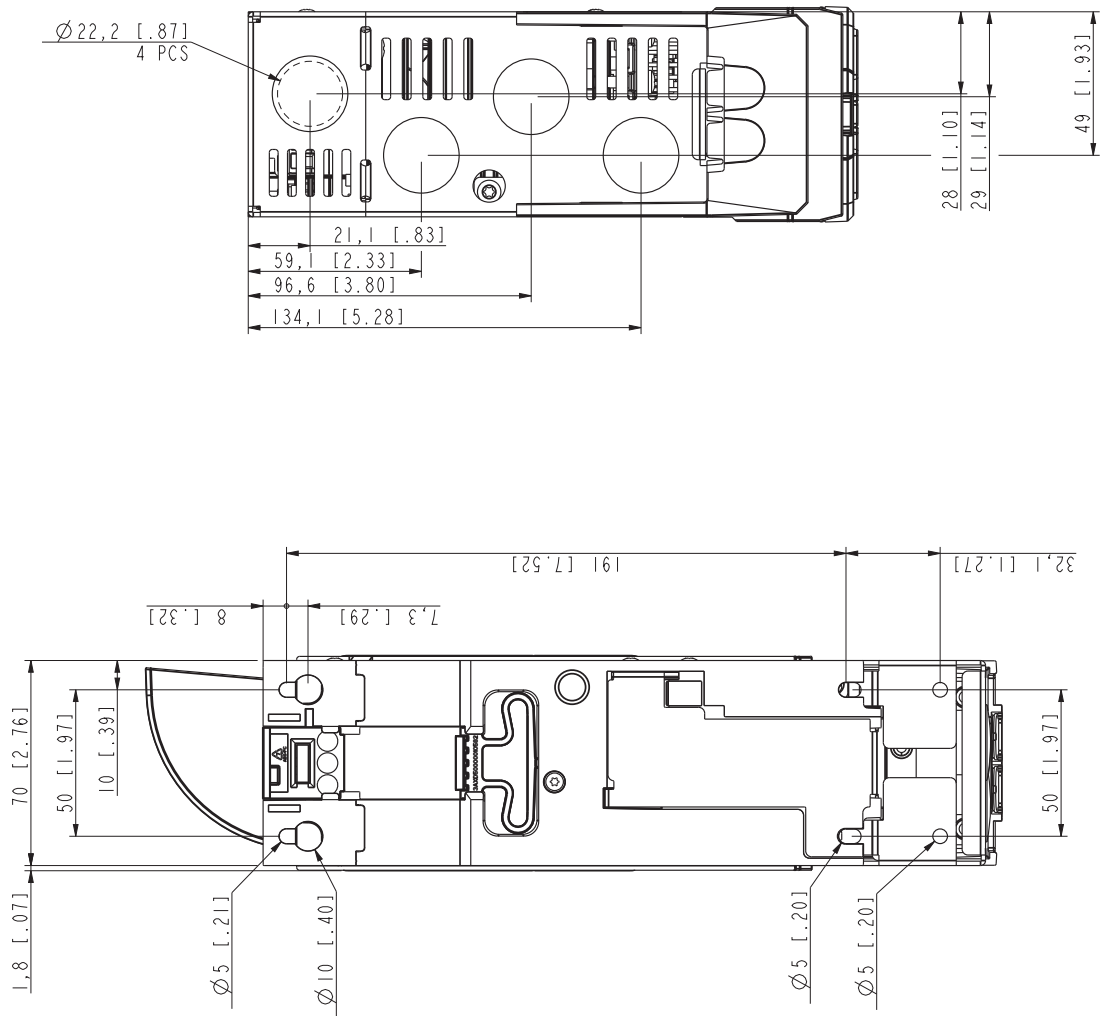

Frame R2

- Frame R2 (front & side) - IP20 / UL type open

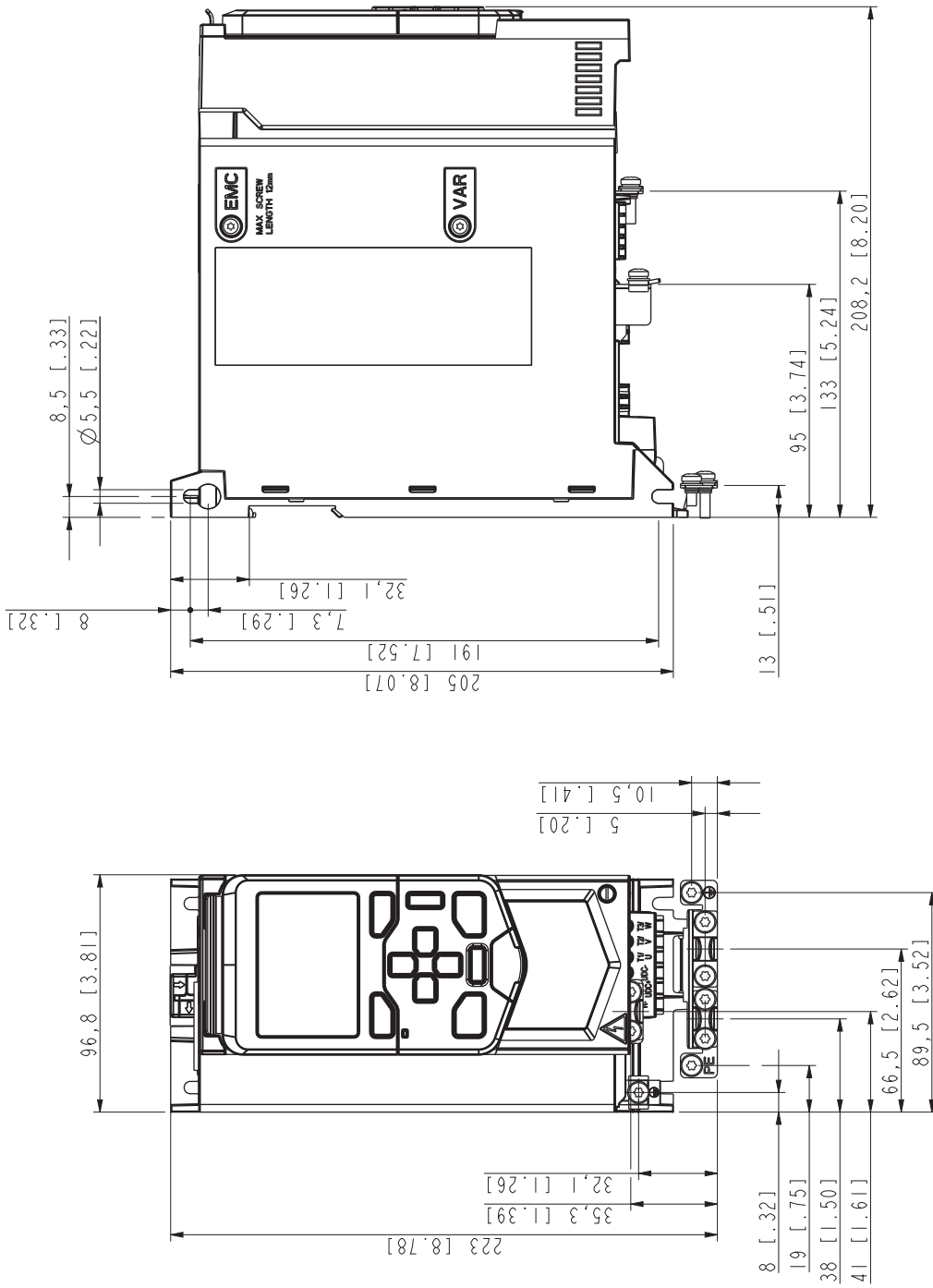

■ Frame R2 (front & side) - UL type 1 kit installed

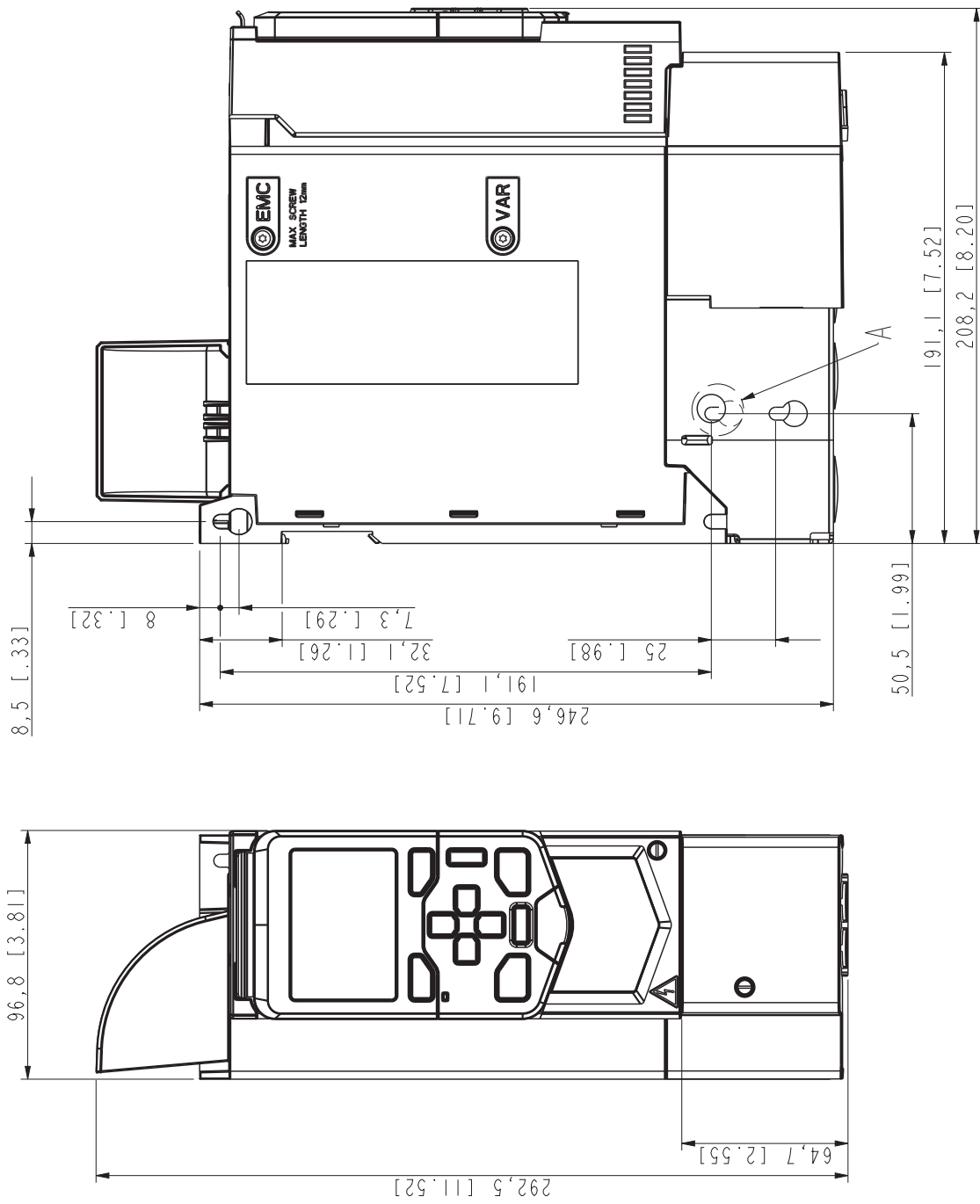

■ Frame R2 (bottom & rear) - UL type 1 kit installed

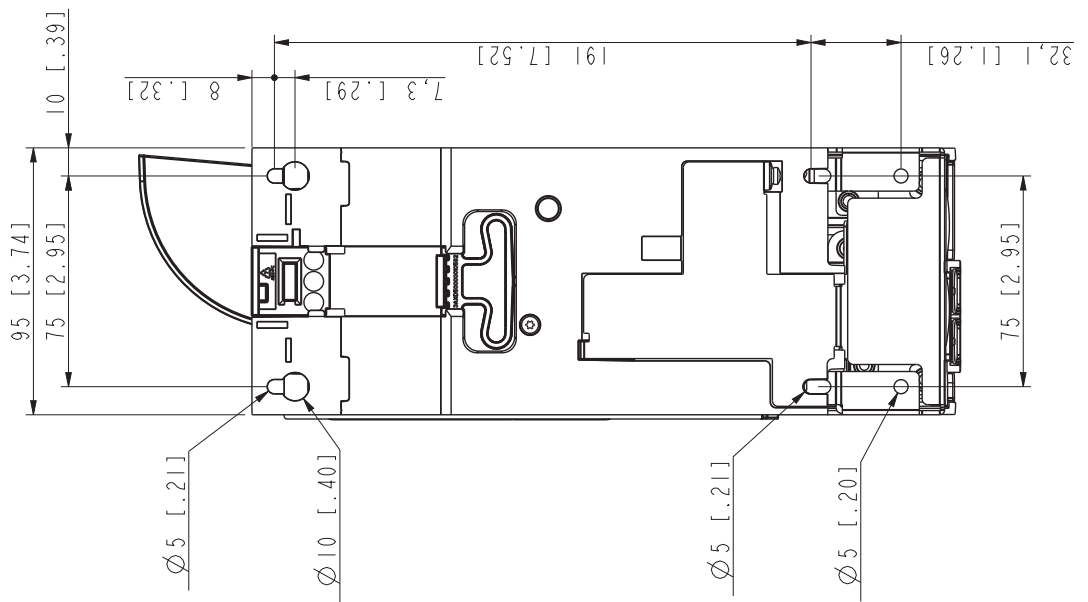
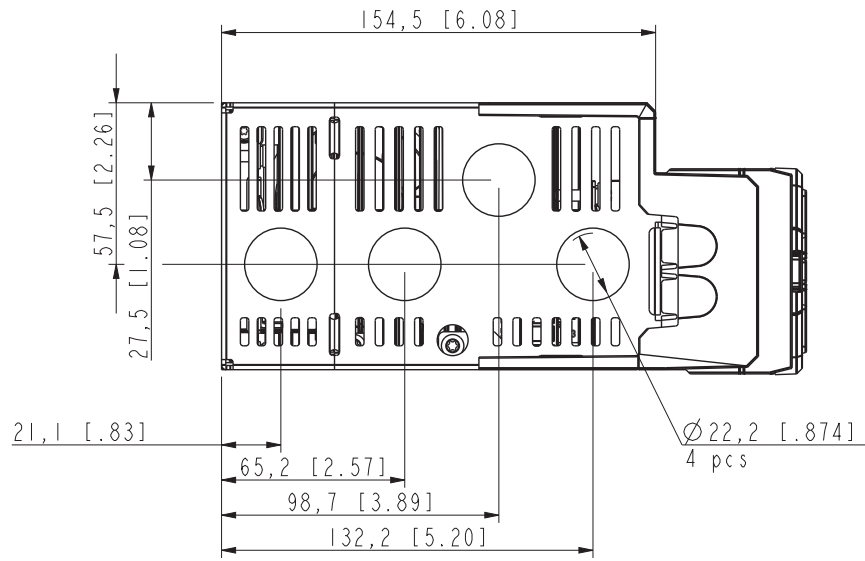

Frame R3

- Frame R3 (front & side) - IP20 / UL type open

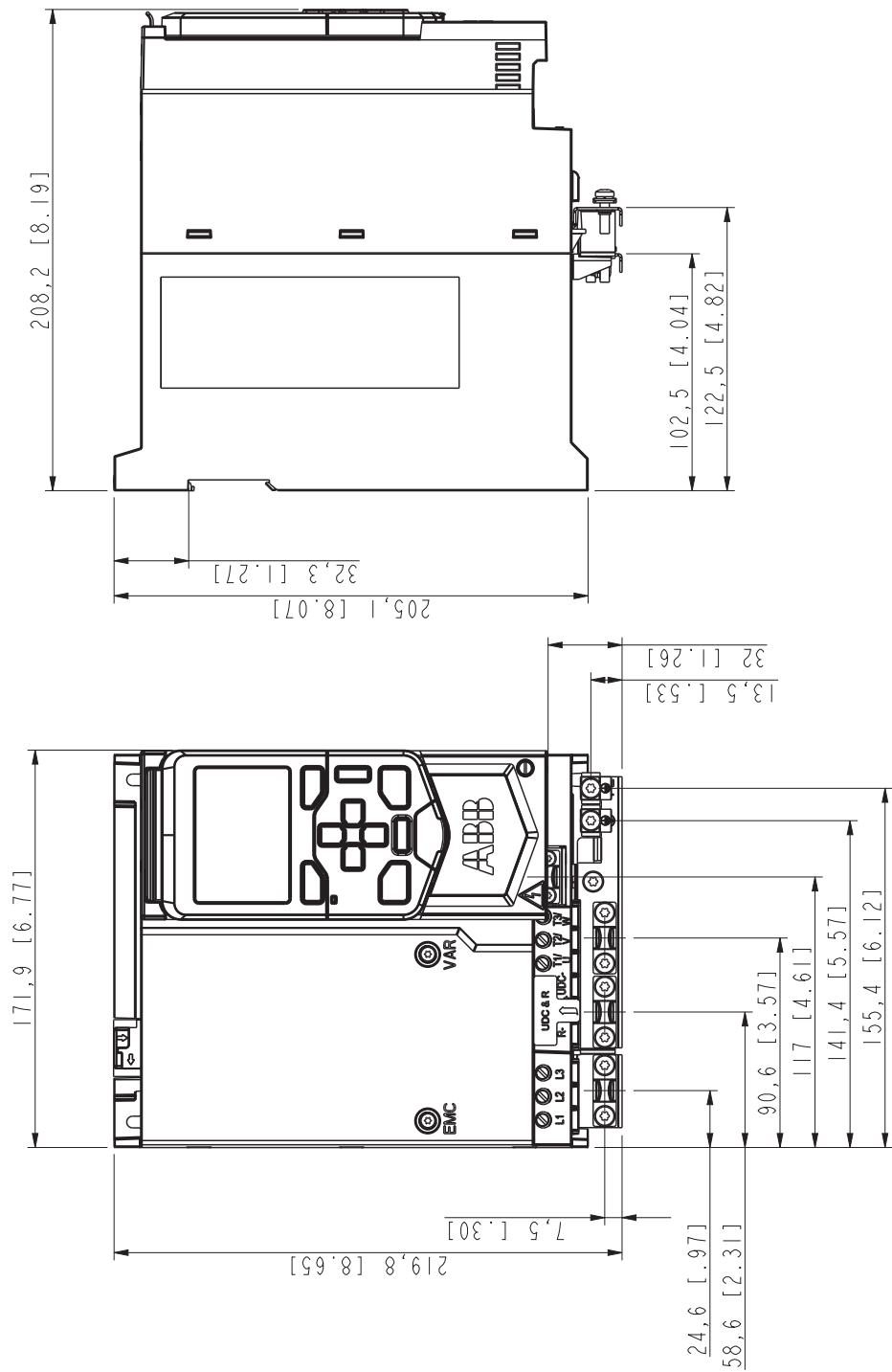

■ Frame R3 (bottom & rear) - IP20 / UL type open

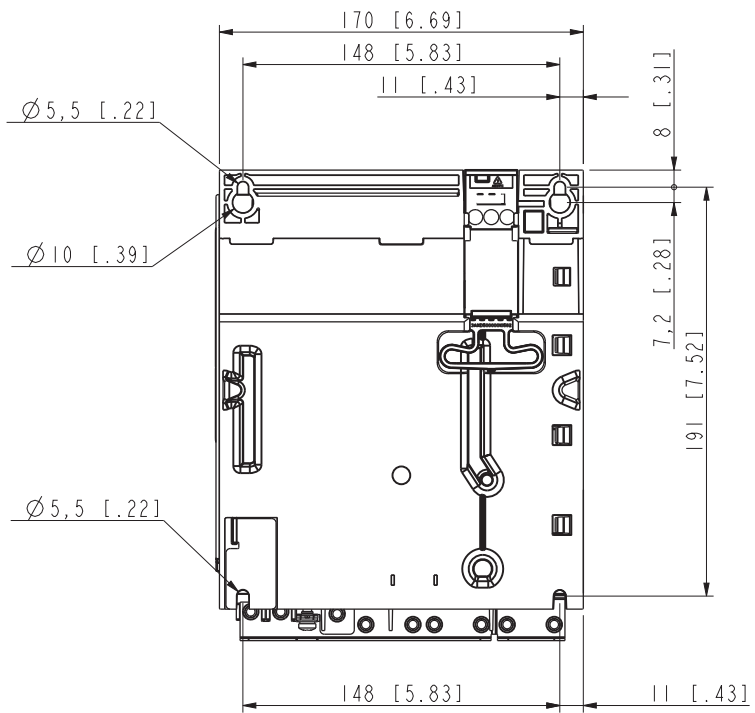
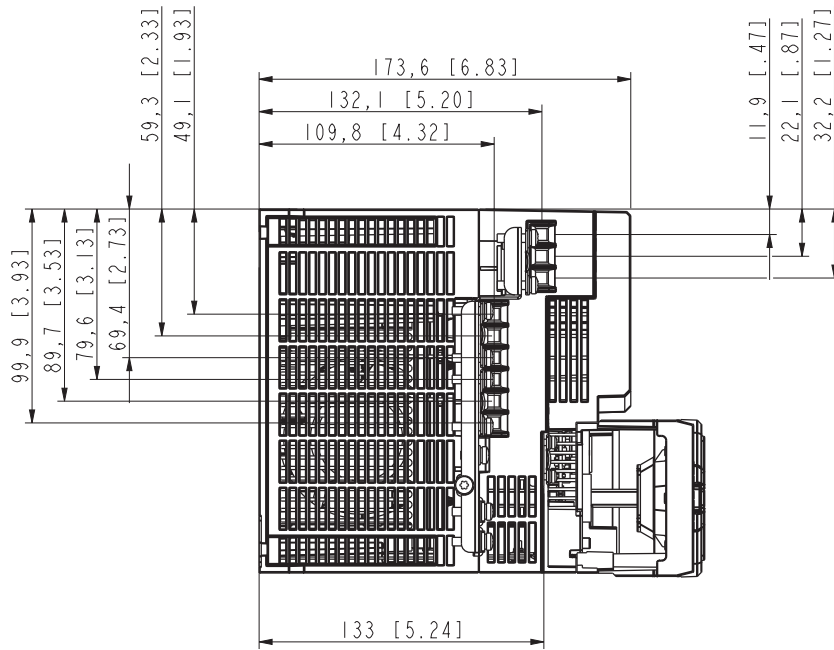

■ Frame R3 (front & side) - UL type 1 kit installed

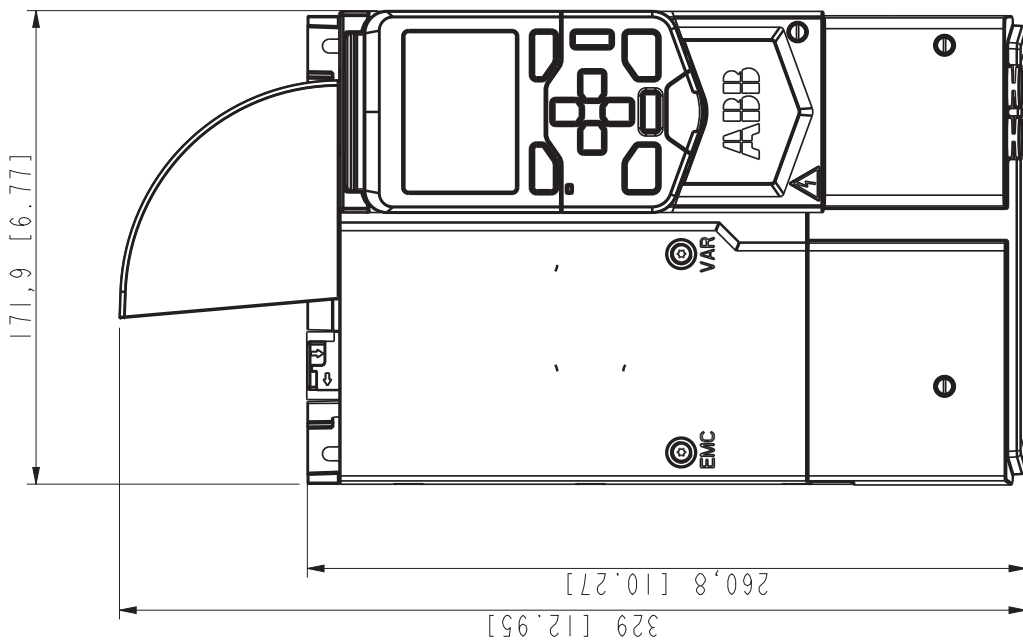
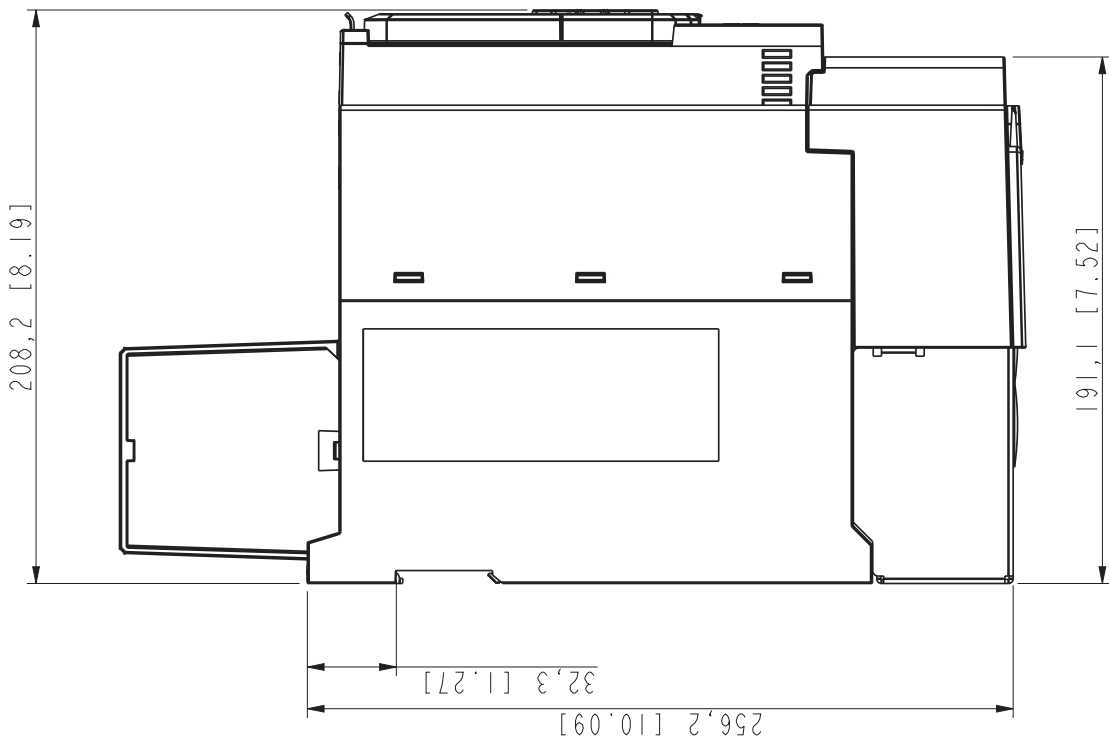

■ Frame R3 (bottom & rear) - UL type 1 kit installed

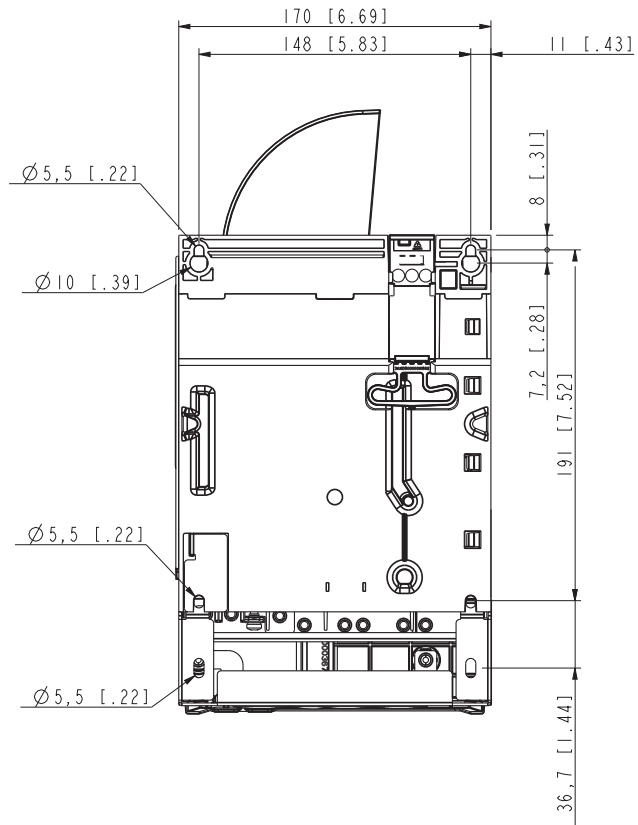
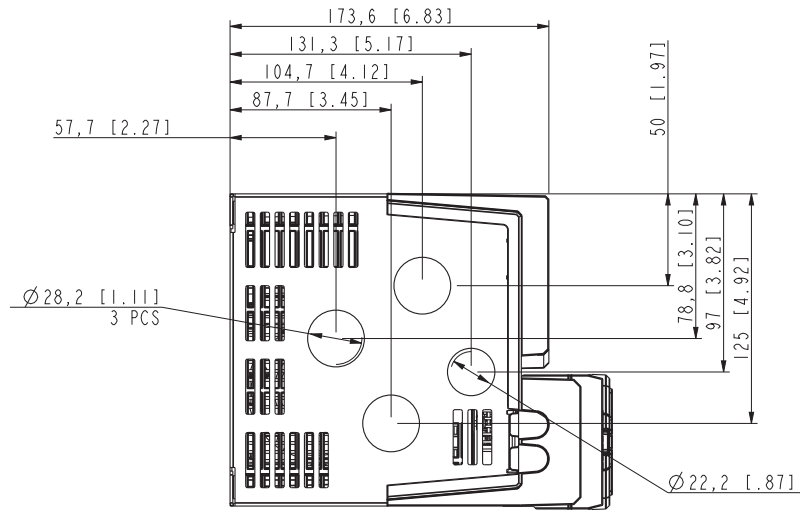

Frame R4

- Frame R4 (front & side) - IP20 / UL type open

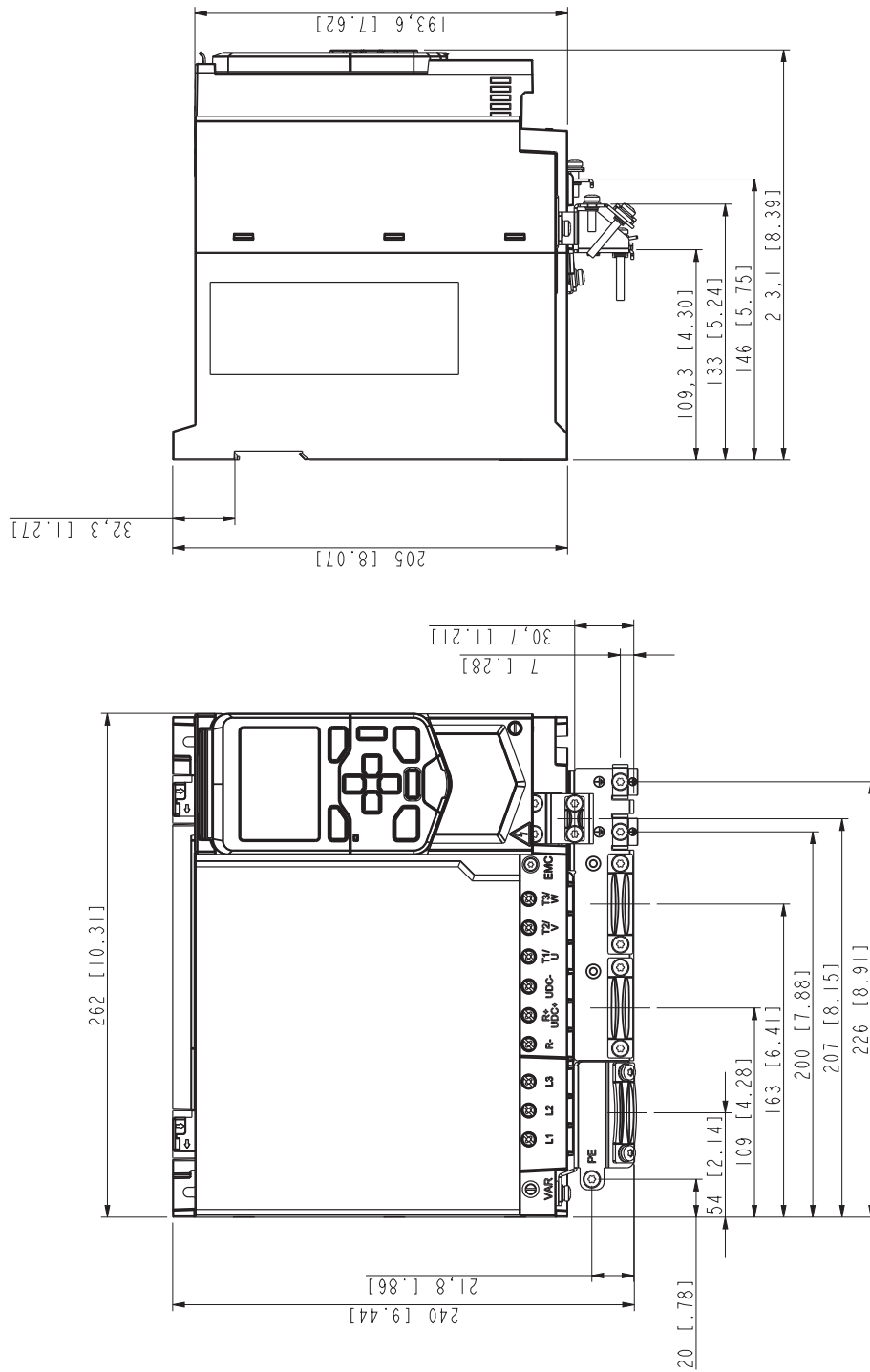

■ Frame R4 (bottom & rear) - IP20 / UL type open

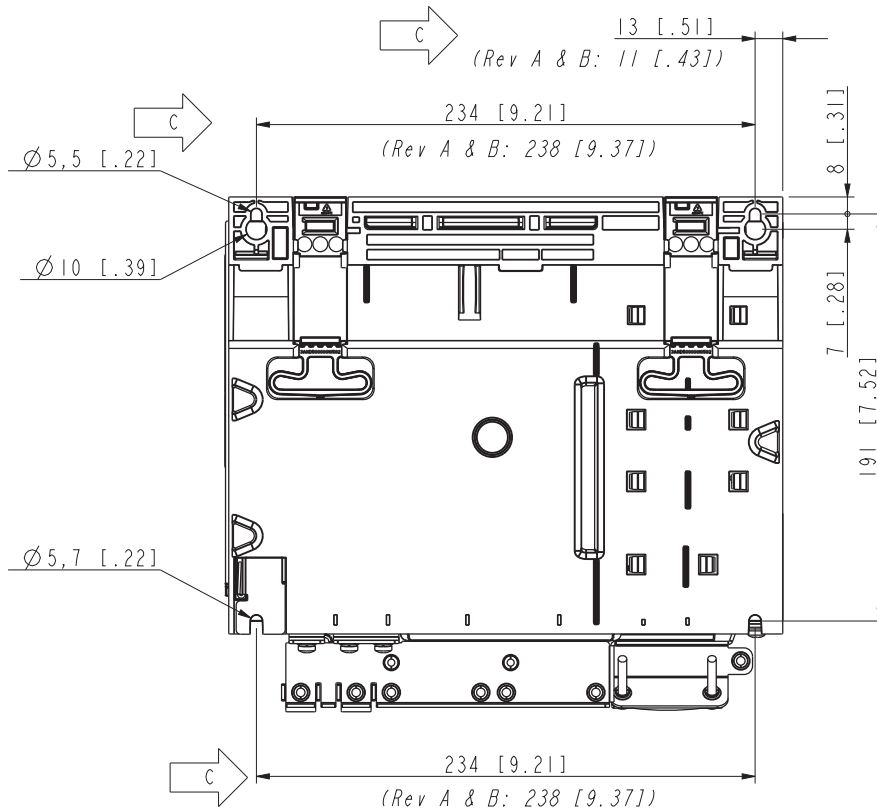
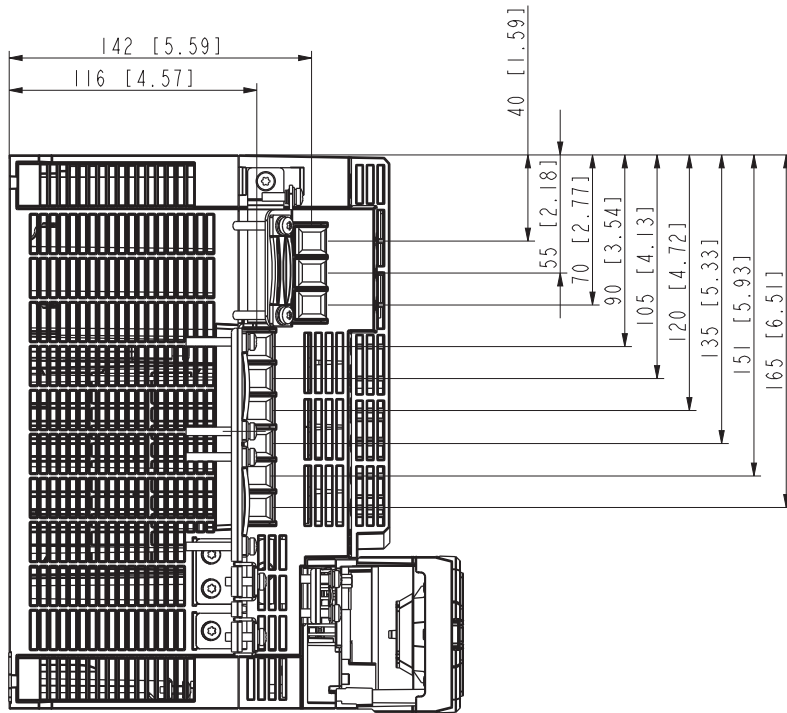

■ Frame R4 (front & side) - UL type 1 kit installed

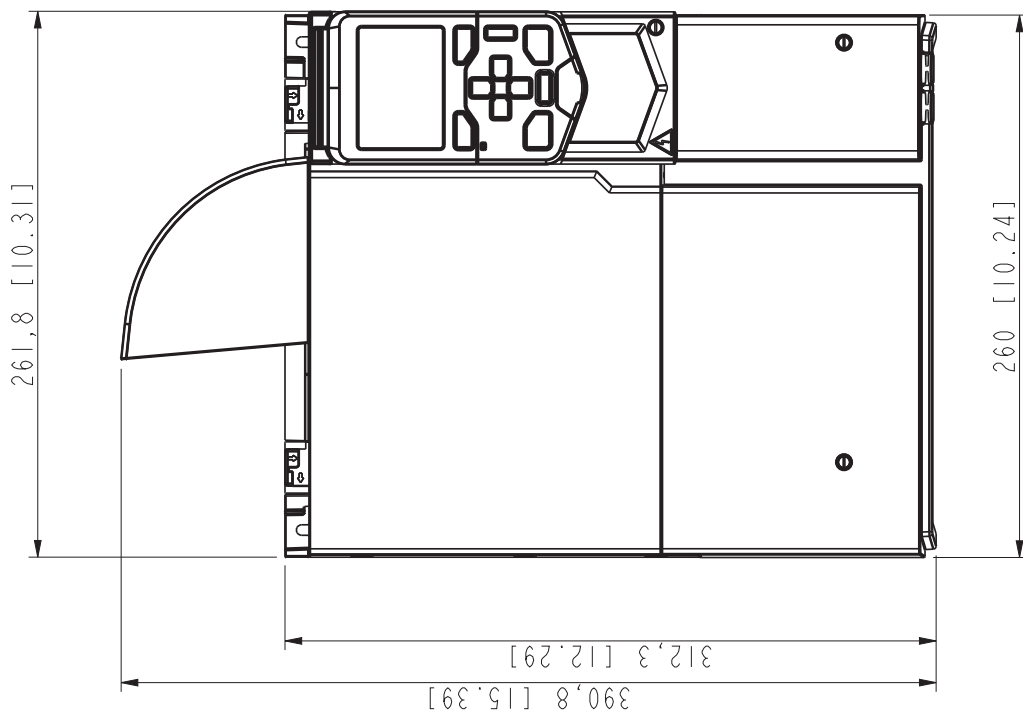
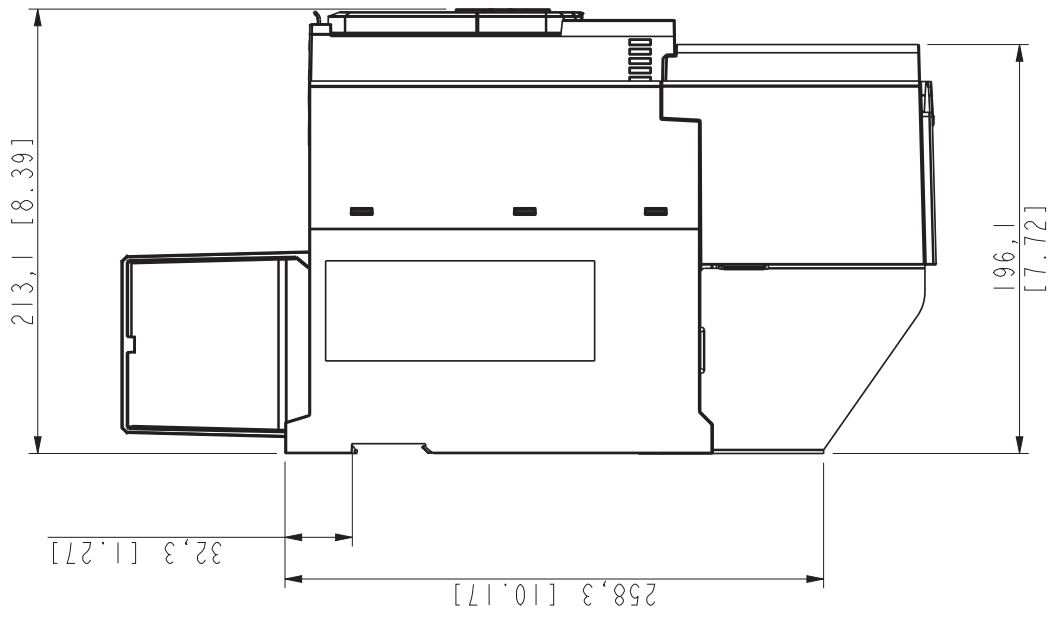

■ Frame R4 (bottom & rear) - UL type 1 kit installed

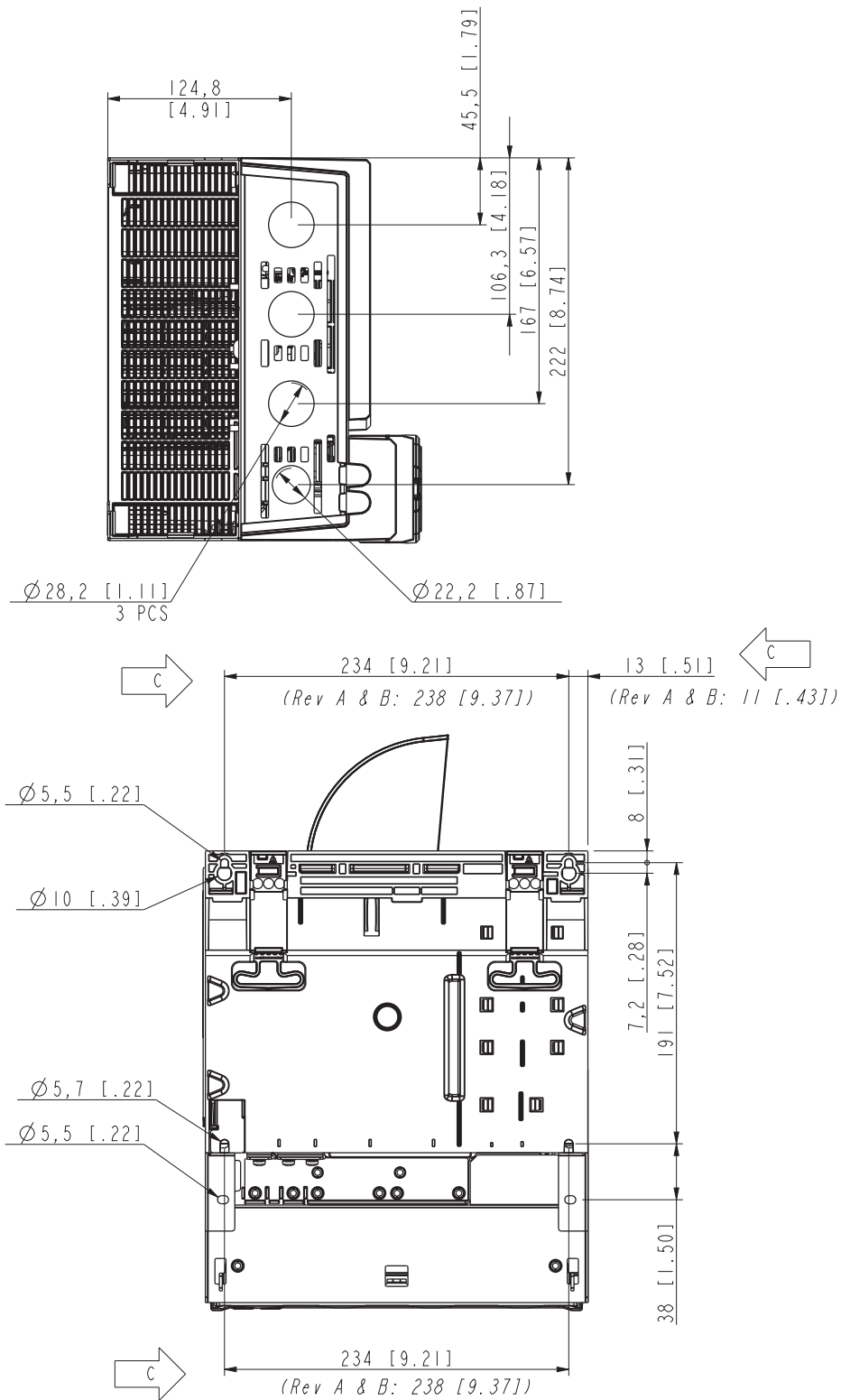

12

Resistor braking

Contents of this chapter

The chapter describes how to select the brake resistor and cables, protect the system, connect the brake resistor and enable resistor braking.

Safety

**WARNING!**

Do not do any work on the brake resistor or the resistor cable, when the drive is energized. A dangerous voltage is present in the resistor circuit, even when the brake chopper is not operating, or when it is disabled by a parameter.

Operating principle

The brake chopper handles the energy generated by a decelerating motor. The extra energy increases the DC link voltage. The chopper connects the brake resistors to the intermediate DC circuit whenever the voltage in the circuit exceeds the limit defined by the control program. Energy consumption by the resistor losses lowers the voltage until the resistors can be disconnected.

Selecting the brake resistor

Drives have a built-in brake chopper as standard equipment. The brake resistor is selected using the table and equations shown in this section.

1. Determine the required maximum braking power P_{Rmax} for the application. P_{Rmax} must be smaller than P_{BRmax} . Refer to *Reference brake resistors (page 143)*.
 2. Calculate resistance R with Equation 1.
 3. Calculate energy E_{Rpulse} with Equation 2.
-

4. Select the resistor so that the following conditions are met:
- The rated power of the resistor must be greater than or equal to P_{Rmax} .
 - Resistance R must be between R_{min} and R_{max} given in the table for the used drive type.
 - The resistor must be able to dissipate energy E_{Rpulse} during the braking cycle T .

Equations for selecting the resistor:

Equation 1

When the drive supply voltage is 200...240 V:

$$R = \frac{150\,000}{P_{Rmax}}$$

When the drive supply voltage is 380...415 V:

$$R = \frac{450\,000}{P_{Rmax}}$$

When the drive supply voltage is 415...480 V:

$$R = \frac{615\,000}{P_{Rmax}}$$

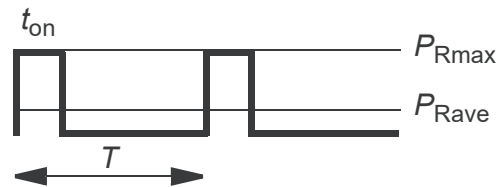

For conversion, use 1 hp = 746 W.

Equation 2

$$E_{Rpulse} = P_{Rmax} \cdot t_{on}$$

Equation 3

$$P_{Rave} = \frac{P_{Rmax} \cdot t_{on}}{T}$$

R	Calculated brake resistor value (ohm). Make sure that: $R_{min} < R < R_{max}$
P_{Rmax}	Maximum power during the braking cycle (W)
P_{Rave}	Average power during the braking cycle (W)
E_{Rpulse}	Energy conducted into the resistor during a single braking pulse (J)
t_{on}	Braking time (one cycle) (s)
T	Braking cycle time (s)



WARNING!

Do not use a brake resistor with a resistance below the minimum value specified for the particular drive. The drive and the internal chopper are not able to handle the overcurrent caused by the low resistance.

■ Reference brake resistors

IEC type ACS480-04-...	R_{min}	R_{max}	P_{BRcont}		P_{BRmax}		Example resistor types Danotherm ¹⁾
	ohm	ohm	kW	hp	kW	hp	
02A7-4	99	628	0.55	0.75	0.83	1.10	CBH 360 C T 406 210R or CAR 200 D T 406 210R
03A4-4	99	428	0.75	1.00	1.13	1.50	
04A1-4	99	285	1.10	1.50	1.65	2.20	
05A7-4	99	206	1.50	2.00	2.25	3.00	
07A3-4	53	139	2.20	2.00	3.30	4.40	CBR-V 330 D T 406 78R UL
09A5-4	53	102	3.00	3.00	4.50	6.00	
12A7-4	32	76	4.00	5.00	6.00	8.00	
018A-4	32	54	5.50	7.50	8.25	11.00	CBR-V 560 D HT 406 39R UL
026A-4	23	39	7.50	10.00	11.25	15.00	
033A-4	6	29	11.00	15.00	17	22.00	CBT-H 560 D HT 406 19R
039A-4	6	24	15.00	20.00	23	30.00	CBT-H 760 D HT 406 16R
046A-4	6	20	18.50	25.00	28	37.00	
050A-4	6	20	22.00	30.00	33	44.00	

¹⁾ Braking cycle differs from that of the drive. Refer to brake resistor manufacturer's documentation.

UL (NEC) type ACS480-04-...	R_{min}	R_{max}	P_{BRcont}		P_{BRmax}		Example resistor types ¹⁾ Danotherm
	ohm	ohm	kW	hp	kW	hp	
02A1-4	99	628	0.55	0.75	0.83	1.10	CBH 360 C T 406 210R or CAR 200 D T 406 210R
03A0-4	99	428	0.75	1.00	1.13	1.50	
03A5-4	99	285	1.10	1.50	1.65	2.20	
04A8-4	99	206	1.50	2.00	2.25	3.00	
06A0-4	53	139	2.20	2.00	3.30	4.40	CBR-V 330 D T 406 78R UL
07A6-4	53	102	3.00	3.00	4.50	6.00	
011A-4	32	76	4.00	5.00	6.00	8.00	
014A-4	32	54	5.50	7.50	8.25	11.00	CBR-V 560 D HT 406 39R UL
021A-4	23	39	7.50	10.00	11.25	15.00	
027A-4	6	29	11.00	15.00	17	22.00	CBT-H 560 D HT 406 19R
034A-4	6	24	15.00	20.00	23	30.00	CBT-H 760 D HT 406 16R
042A-4	6	20	22.00	30.00	33	44.00	

¹⁾ Braking cycle differs from that of the drive. Refer to brake resistor manufacturer's documentation.

Definitions

P_{BRmax} The maximum braking capacity of the drive, when the length of the braking pulse is at most 1 minute for each 10 minutes ($P_{BRcont} \times 1.5$). Must exceed the desired braking power.

P_{BRcont} The continuous braking capacity of the drive.

R_{max} The maximum resistance value of the brake resistor that can provide P_{BRcont}

R_{min} The minimum allowed resistance value of the brake resistor

Selecting and routing the brake resistor cables

Use a shielded cable specified in the technical data.

■ Minimizing electromagnetic interference

Follow these rules in order to minimize electromagnetic interference caused by the rapid current changes in the resistor cables:

- Shield the braking power line completely, either by using shielded cable or a metallic enclosure. Unshielded single-core cable can only be used if it is routed inside a cabinet that efficiently suppresses the radiated emissions.
- Install the cables away from other cable routes.
- Avoid long parallel runs with other cables. The minimum parallel cabling separation distance is 0.3 meters (1 ft).
- Cross the other cables at 90 degree angles.
- Keep the cable as short as possible in order to minimize the radiated emissions and stress on chopper IGBTs. The longer the cable the greater the radiated emissions, inductive load and voltage peaks over the IGBT semiconductors of the brake chopper.

Note: ABB has not verified that the EMC requirements are fulfilled with custom brake resistors and cabling. The customer must consider the EMC compliance of the complete installation.

■ Maximum cable length

The maximum length of the resistor cable(s) is 10 m (33 ft).

Placing custom brake resistors

Install the resistors outside the drive in a place where they are able to cool effectively.

Arrange the cooling of the resistor in a way that

- no danger of overheating is caused to the resistor or nearby materials, and
- the temperature of the room the resistor is located in does not exceed the allowed maximum.

Supply the resistor with cooling air or coolant according to the resistor manufacturer's instructions.



WARNING!

The materials near the brake resistor must be non-flammable. The surface temperature of the resistor is high. Air flowing from the resistor is of hundreds of degrees Celsius. If the exhaust vents are connected to a ventilation system, make sure that the material withstands high temperatures. Protect the resistor against contact.

Protecting the system in brake circuit fault situations

■ Protecting the system in cable and brake resistor short-circuit situations

The drive input fuses will also protect the resistor cable when it is identical with the input power cable.

■ Protecting the system against thermal overload

The drive has a brake thermal model which protects the brake resistor against overload. ABB recommends to enable the thermal model at start up.

Equipping the drive with a main contactor is highly recommended for safety reasons even when you have enabled the resistor thermal model. Wire the contactor so that it opens in case the resistor overheats. This is essential for safety since the drive will not otherwise be able to interrupt the main supply if the chopper remains conductive in a fault situation. An example wiring diagram is shown below. We recommend that you use resistors equipped with a thermal switch (1) inside the resistor assembly. The switch indicates overtemperature.

ABB recommends that you also wire the thermal switch to a digital input of the drive, and configure the input to cause a fault trip at resistor overtemperature indication.

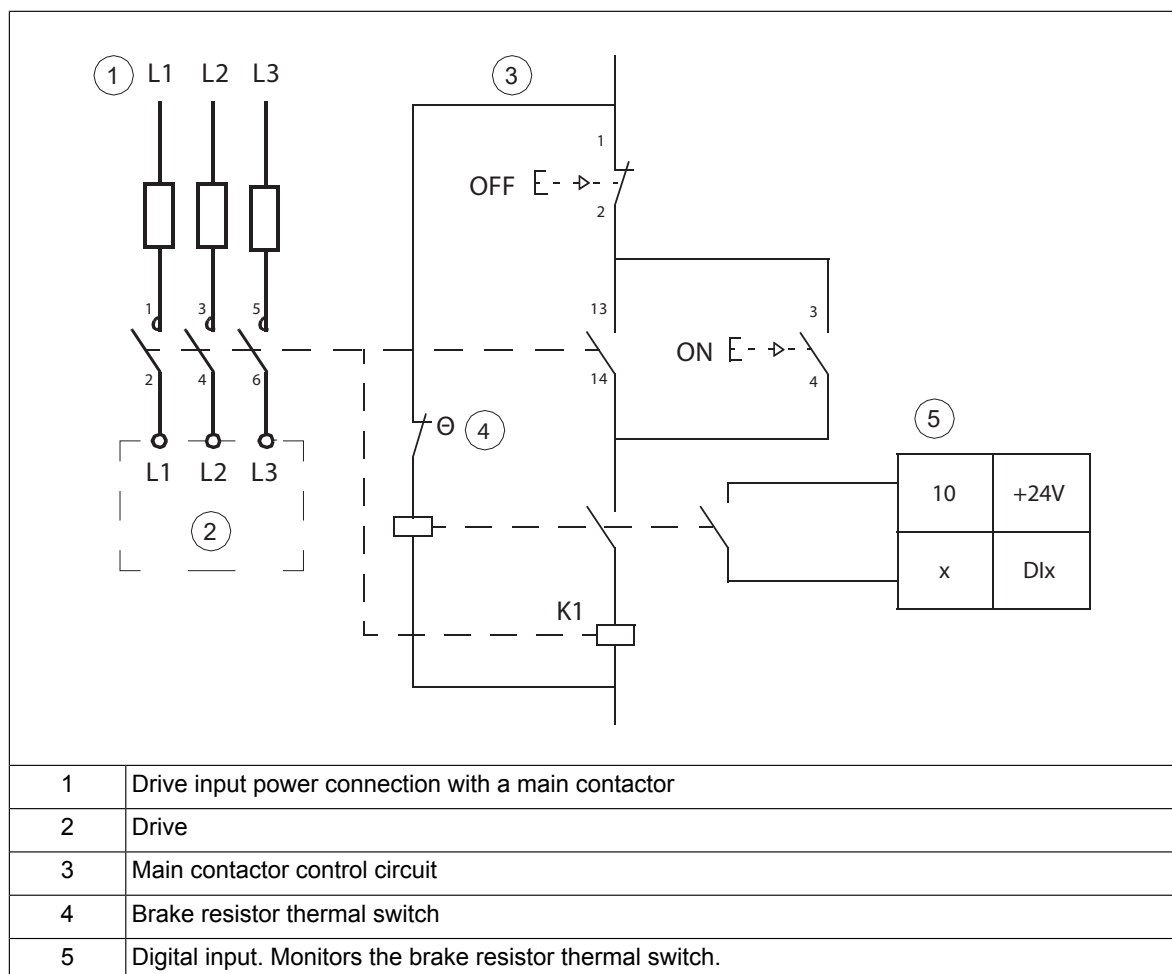

Mechanical and electrical installation of brake resistor



WARNING!

Obey the safety instructions of the drive. If you ignore them, injury or death, or damage to the equipment can occur.

If you are not a qualified electrical professional, do not do installation or maintenance work.



WARNING!

Stop the drive and do the steps in section [Electrical safety precautions \(page 14\)](#) before you start the work.

■ **Mechanical installation**

Refer to the resistor manufacturer's instructions.

■ **Electrical installation**

Measuring the insulation

See the electrical installation instructions of the drive.

Connecting power cables

See the electrical installation instructions of the drive.

Connection the control cables

Connect the thermal switch of the brake resistor as described in [Protecting the system against thermal overload \(page 145\)](#).

Start-up

Set the following parameters:

1. Disable the overvoltage control of the drive with parameter *30.30 Overvoltage control*.
2. Set the source of parameter *31.01 External event 1 source* to point to the digital input where the thermal switch of the brake resistor is wired.
3. Set parameter *31.02 External event 1 type* to *Fault*.
4. Enable the brake chopper by parameter *43.06 Brake chopper enable*. If *Enabled with thermal model* is selected, set also the brake resistor overload protection parameters *43.08* and *43.09* according to the application.
5. Check the resistance value of parameter *43.10 Brake resistance*.

With these parameter settings, the drive generates a fault and coasts to a stop on brake resistor overtemperature.

13

The Safe torque off function

Contents of this chapter

This chapter describes the Safe torque off (STO) function of the drive and gives instructions for its use.

Description

The Safe torque off function can be used, for example, to as the final actuator device of safety circuits that stop the drive in case of danger (such as an emergency stop circuit). Another typical application is a prevention of unexpected start-up function that enables short-time maintenance operations like cleaning or work on non-electrical parts of the machinery without switching off the power supply to the drive.

When activated, the Safe torque off function disables the control voltage of the power semiconductors of the drive output stage (A, see the diagrams below), thus preventing the drive from generating the torque required to rotate the motor. If the motor is running when Safe torque off is activated, it coasts to a stop.

The Safe torque off function has a redundant architecture, that is, both channels must be used in the safety function implementation. The safety data given in this manual is calculated for redundant use, and does not apply if both channels are not used.

The Safe torque off function complies with these standards:

Standard	Name
IEC 60204-1:2016 EN 60204-1:2006 + A1:2009 + AC:2010	<i>Safety of machinery – Electrical equipment of machines – Part 1: General requirements</i>
IEC 61000-6-7:2014	<i>Electromagnetic compatibility (EMC) – Part 6-7: Generic standards – Immunity requirements for equipment intended to perform functions in a safety-related system (functional safety) in industrial locations</i>

Standard	Name
IEC 61326-3-1:2017	<i>Electrical equipment for measurement, control and laboratory use – EMC requirements – Part 3-1: Immunity requirements for safety-related systems and for equipment intended to perform safety-related functions (functional safety) – General industrial applications</i>
IEC 61508-1:2010	<i>Functional safety of electrical/electronic/programmable electronic safety-related systems – Part 1: General requirements</i>
IEC 61508-2:2010	<i>Functional safety of electrical/electronic/programmable electronic safety-related systems – Part 2: Requirements for electrical/electronic/programmable electronic safety-related systems</i>
IEC 61511-1:2016	<i>Functional safety – Safety instrumented systems for the process industry sector</i>
IEC 61800-5-2:2016 EN 61800-5-2:2007	<i>Adjustable speed electrical power drive systems – Part 5-2: Safety requirements – Functional</i>
IEC 62061:2005 + A1:2012 + A2:2015 EN 62061:2005 + AC:2010 + A1:2013 + A2:2015	<i>Safety of machinery – Functional safety of safety-related electrical, electronic and programmable electronic control systems</i>
EN ISO 13849-1:2015	<i>Safety of machinery – Safety-related parts of control systems – Part 1: General principles for design</i>
EN ISO 13849-2:2012	<i>Safety of machinery – Safety-related parts of control systems – Part 2: Validation</i>

The function also corresponds to Prevention of unexpected start-up as specified by EN ISO 14118:2018 (ISO 14118:2017), and Uncontrolled stop (stop category 0) as specified in EN/IEC 60204-1.

■ **Compliance with the European Machinery Directive**

See the technical data.

The Declaration of conformity is shown at the end of this chapter.

Wiring

For the electrical specifications of the STO connection, see the technical data of the control unit.

■ Connection principle

Single ACS480 drive, internal power supply

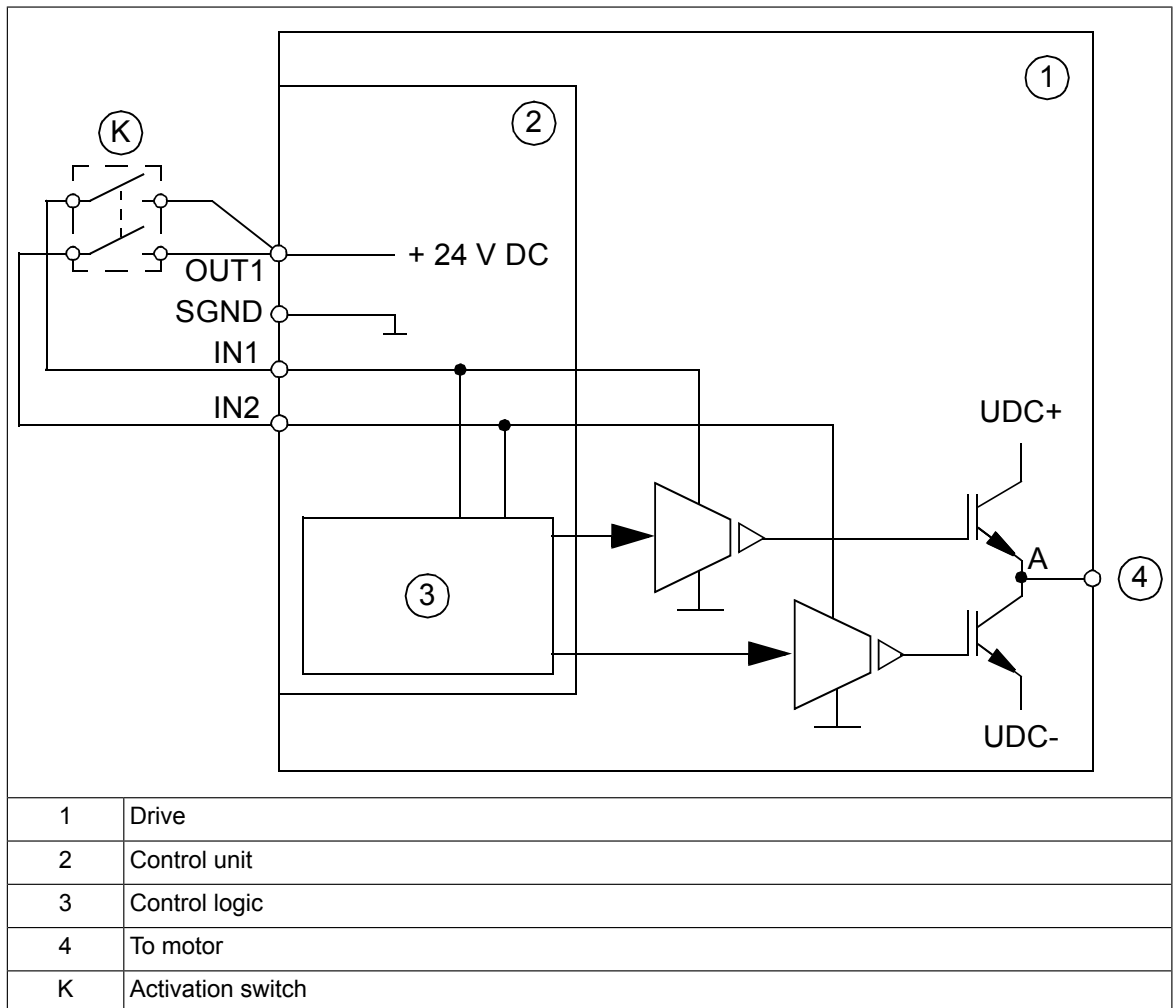

Single ACS480 drive, external power supply

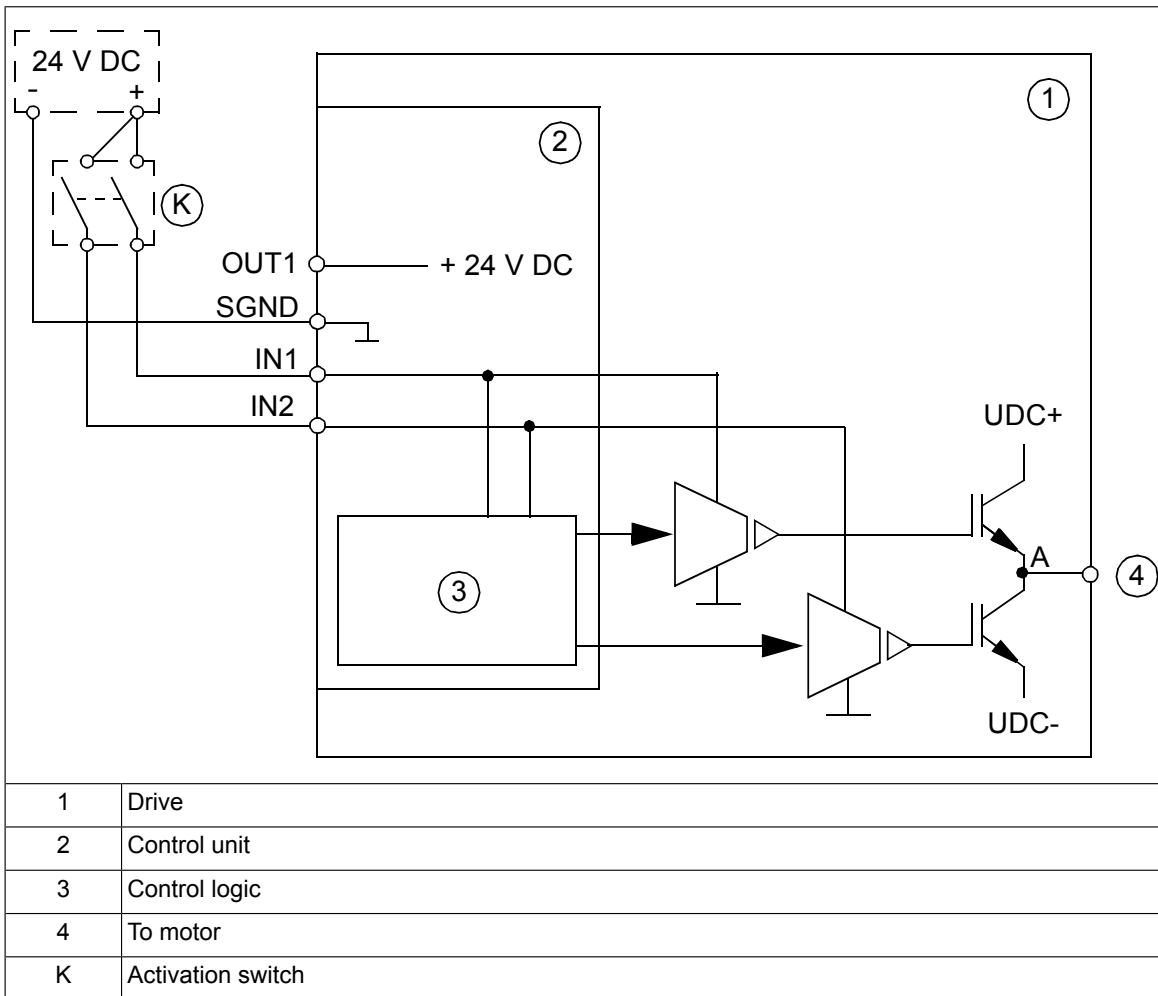

■ **Wiring examples**

Single ACS480 drive, internal power supply

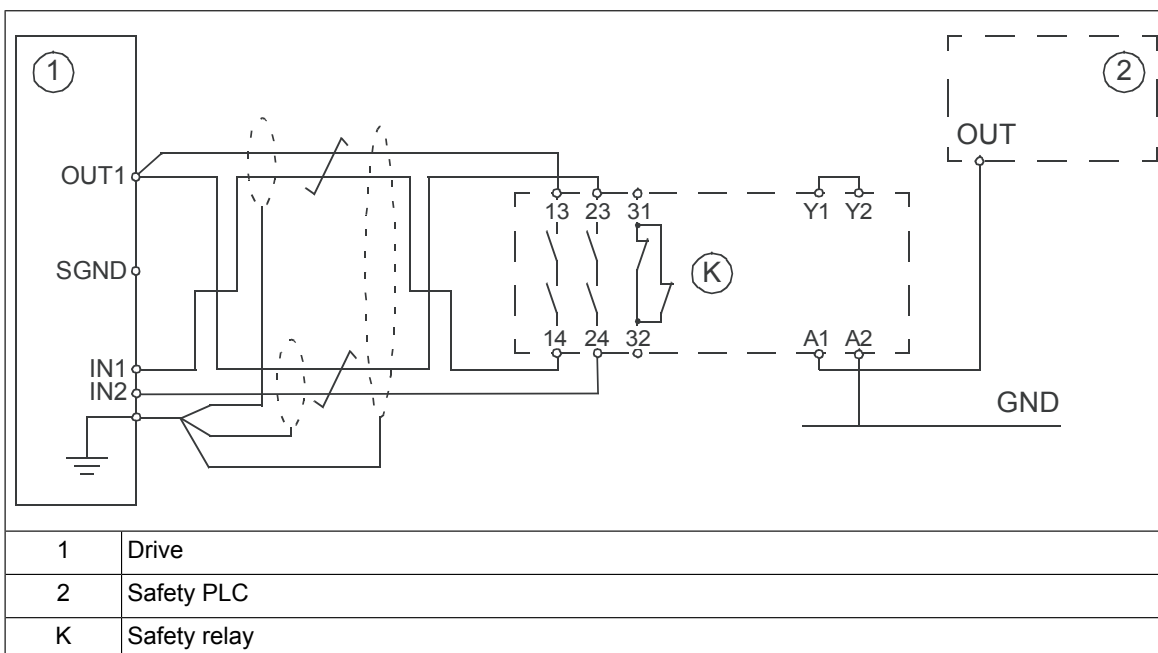

Single ACS480 drive, external power supply

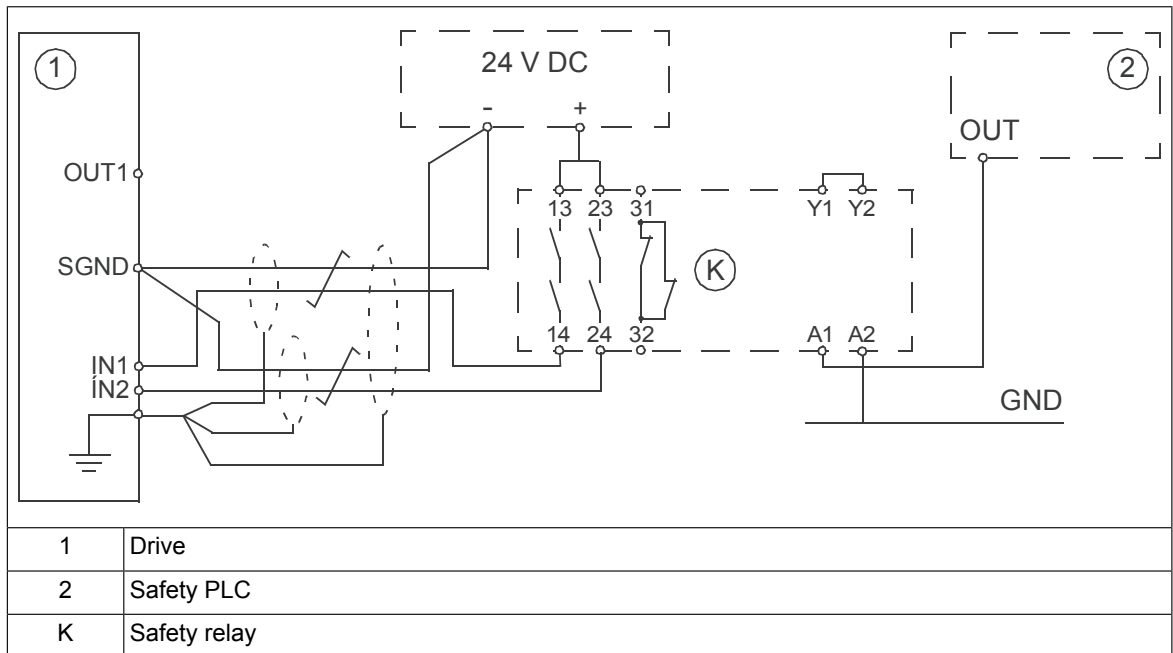

Multiple ACS480 drives, internal power supply

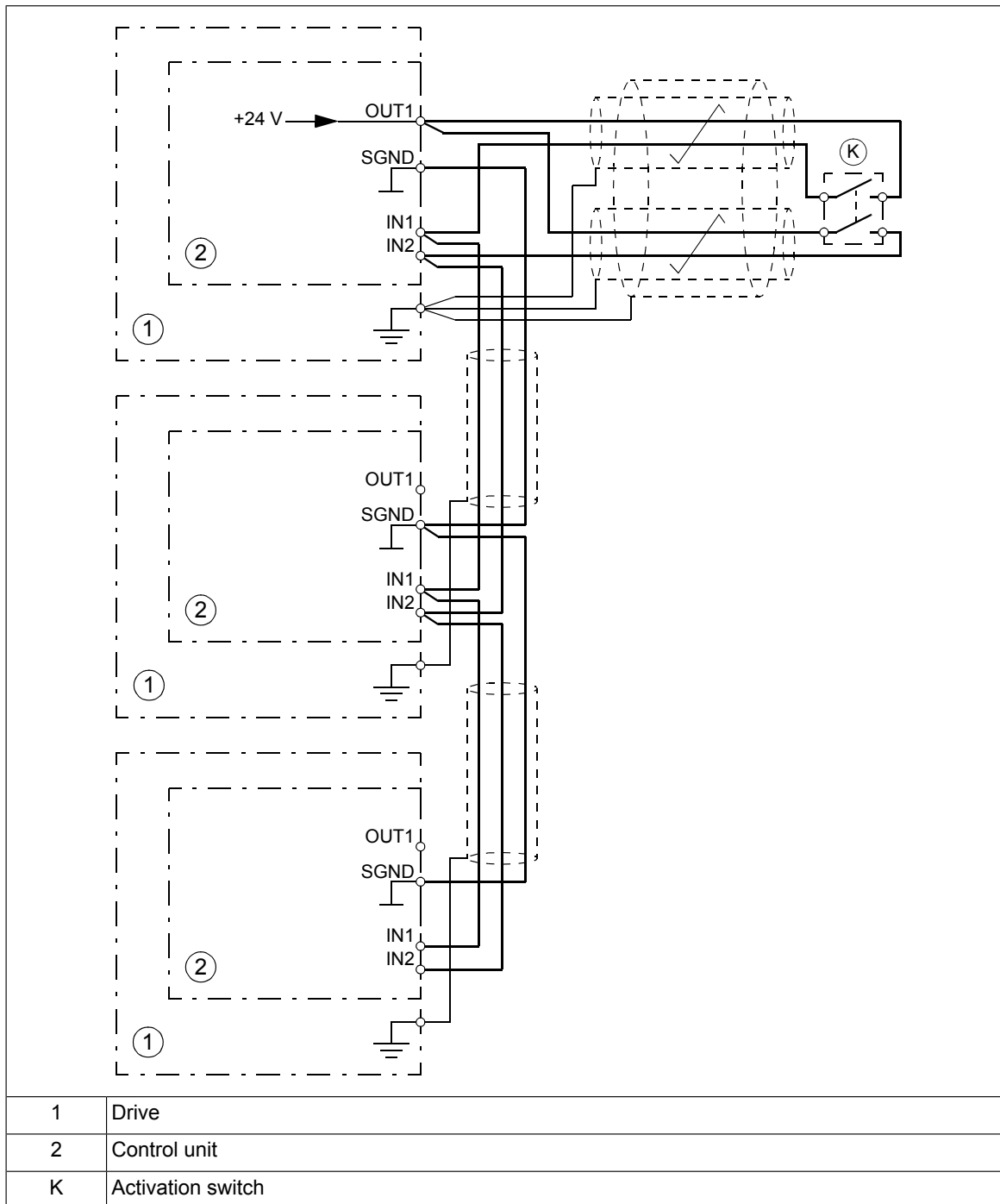

Multiple ACS480 drives, external power supply

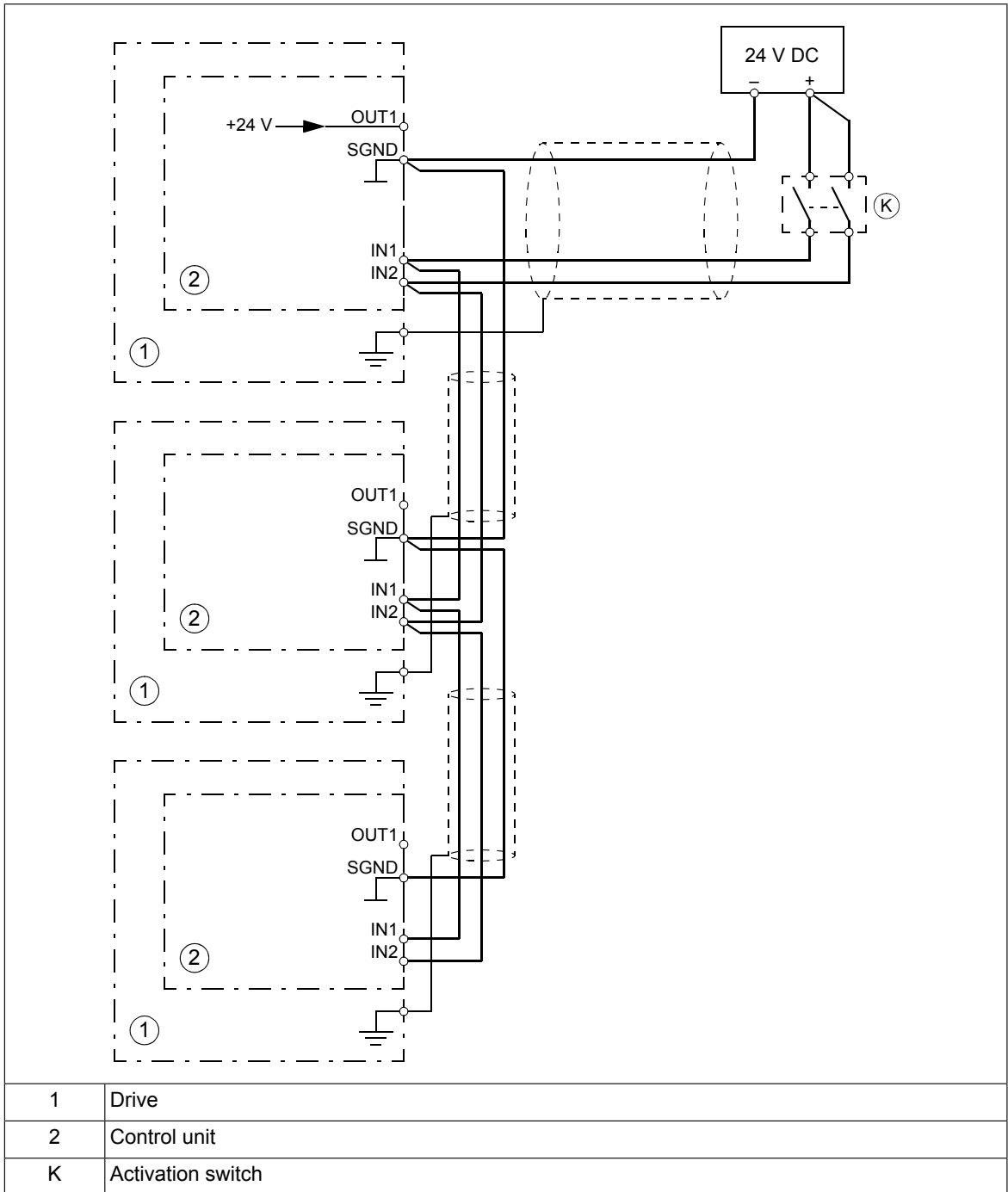

■ **Activation switch**

In the wiring diagrams, the activation switch has the designation [K]. This represents a component such as a manually operated switch, an emergency stop push button switch, or the contacts of a safety relay or safety PLC.

- In case a manually operated activation switch is used, the switch must be of a type that can be locked out to the open position.
- The contacts of the switch or relay must open/close within 200 ms of each other.

■ **Cable types and lengths**

- Double-shielded twisted-pair cable is recommended.

- Maximum cable lengths:
 - 300 m (1000 ft) between activation switch [K] and drive control unit
 - 60 m (200 ft) between multiple drives or inverter units
 - 60 m (200 ft) between external power supply and first control unit

Note: A short-circuit in the wiring between the switch and an STO terminal causes a dangerous fault. Therefore, it is recommended to use a safety relay (including wiring diagnostics) or a wiring method (shield grounding, channel separation) which reduces or eliminates the risk caused by the short-circuit.

Note: The voltage at the STO input terminals of the drive must be at least 13 V DC to be interpreted as “1”.

The pulse tolerance of the input channels is 1 ms.

■ **Grounding of protective shields**

- Ground the shield in the cabling between the activation switch and the control unit at the control unit only.
 - Ground the shield in the cabling between two control units at one control unit only.
-

Operation principle

1. The Safe torque off activates (the activation switch is opened, or safety relay contacts open).
2. The STO inputs of the drive control unit de-energize.
3. The control unit cuts off the control voltage from the output IGBTs.
4. The control program generates an indication as defined by parameter 31.22 (see the firmware manual of the drive).

The parameter selects which indications are given when one or both STO signals are switched off or lost. The indications also depend on whether the drive is running or stopped when this occurs.

Note: This parameter does not affect the operation of the STO function itself. The STO function will operate regardless of the setting of this parameter: a running drive will stop upon removal of one or both STO signals, and will not start until both STO signals are restored and all faults reset.

Note: The loss of only one STO signal always generates a fault as it is interpreted as a malfunction of STO hardware or wiring.

5. The motor coasts to a stop (if running). The drive cannot restart while the activation switch or safety relay contacts are open. After the contacts close, a reset may be needed (depending on the setting of parameter 31.22). A new start command is required to start the drive.
-

Start-up including acceptance test

To ensure the safe operation of a safety function, validation is required. The final assembler of the machine must validate the function by performing an acceptance test. The acceptance test must be performed

- at initial start-up of the safety function
- after any changes related to the safety function (circuit boards, wiring, components, settings, etc.)
- after any maintenance work related to the safety function.

■ Competence

The acceptance test of the safety function must be carried out by a competent person with adequate expertise and knowledge of the safety function as well as functional safety, as required by IEC 61508-1 clause 6. The test procedures and report must be documented and signed by this person.

■ Acceptance test reports

Signed acceptance test reports must be stored in the logbook of the machine. The report shall include documentation of start-up activities and test results, references to failure reports and resolution of failures. Any new acceptance tests performed due to changes or maintenance shall be logged into the logbook.

■ Acceptance test procedure

After wiring the Safe torque off function, validate its operation as follows.

Action	<input checked="" type="checkbox"/>
 WARNING! Obey the safety instructions. If you ignore them, injury or death, or damage to the equipment can occur.	<input type="checkbox"/>
Make sure that the drive can be run and stopped freely during start-up.	<input type="checkbox"/>
Stop the drive (if running), switch the input power off and isolate the drive from the power line using a disconnecter.	<input type="checkbox"/>
Check the STO circuit connections against the wiring diagram.	<input type="checkbox"/>
Close the disconnecter and switch the power on.	<input type="checkbox"/>
Test the operation of the STO function when the motor is stopped. <ul style="list-style-type: none"> • Give a stop command for the drive (if running) and wait until the motor shaft is at a standstill. Make sure that the drive operates as follows: <ul style="list-style-type: none"> • Open the STO circuit. The drive generates an indication if one is defined for the 'stopped' state in parameter 31.22 (see the firmware manual). • Give a start command to verify that the STO function blocks the drive's operation. The drive generates a warning. The motor should not start. • Close the STO circuit. • Reset any active faults. Restart the drive and check that the motor runs normally. 	<input type="checkbox"/>

Action	<input checked="" type="checkbox"/>
<p>Test the operation of the STO function when the motor is running.</p> <ul style="list-style-type: none"> • Start the drive and make sure the motor is running. • Open the STO circuit. The motor should stop. The drive generates an indication if one is defined for the 'running' state in parameter 31.22 (see the firmware manual). • Reset any active faults and try to start the drive. • Make sure that the motor stays at a standstill and the drive operates as described above in testing the operation when the motor is stopped. • Close the STO circuit. • Reset any active faults. Restart the drive and check that the motor runs normally. 	<input type="checkbox"/>
<p>Test the operation of the failure detection of the drive. The motor can be stopped or running.</p> <ul style="list-style-type: none"> • Open the 1st channel of the STO circuit (wire coming to IN1). If the motor was running, it should coast to a stop. The drive generates a <i>FA81 Safe Torque Off 1 loss</i> fault indication (see the firmware manual). • Give a start command to verify that the STO function blocks the drive's operation. The motor should not start. • Close the STO circuit. • Reset any active faults. Restart the drive and check that the motor runs normally. • Open the 2nd channel of the STO circuit (wire coming to IN2). If the motor was running, it should coast to a stop. The drive generates a <i>FA82 Safe Torque Off 2 loss</i> fault indication (see the firmware manual). • Give a start command to verify that the STO function blocks the drive's operation. The motor should not start. • Close the STO circuit. • Reset any active faults. Restart the drive and check that the motor runs normally. 	<input type="checkbox"/>
<p>Document and sign the acceptance test report which verifies that the safety function is safe and accepted for operation.</p>	<input type="checkbox"/>

Use

1. Open the activation switch, or activate the safety functionality that is wired to the STO connection.
2. The STO inputs on the drive control unit de-energize, and the control unit cuts off the control voltage from the output IGBTs.
3. The control program generates an indication as defined by parameter 31.22 (see the firmware manual of the drive).
4. The motor coasts to a stop (if running). The drive will not restart while the activation switch or safety relay contacts are open.
5. Deactivate the STO by closing the activation switch, or resetting the safety functionality that is wired to the STO connection.
6. Reset any faults before restarting.



WARNING!

The Safe torque off function does not disconnect the voltage of the main and auxiliary circuits from the drive. Therefore maintenance work on electrical parts of the drive or the motor can only be carried out after isolating the drive from the supply and all other voltage sources.



WARNING!

(With permanent magnet or synchronous reluctance [SynRM] motors only)

In case of a multiple IGBT power semiconductor failure, the drive can produce an alignment torque which maximally rotates the motor shaft by $180/p$ degrees (with permanent magnet motors) or $180/2p$ degrees (with synchronous reluctance [SynRM] motors) regardless of the activation of the Safe torque off function. p denotes the number of pole pairs.

Notes:

- If a running drive is stopped by using the Safe torque off function, the drive will cut off the motor supply voltage and the motor will coast to a stop. If this causes danger or is not otherwise acceptable, stop the drive and machinery using the appropriate stop mode before activating the Safe torque off function.
 - The Safe torque off function overrides all other functions of the drive.
 - The Safe torque off function is ineffective against deliberate sabotage or misuse.
 - The Safe torque off function has been designed to reduce the recognized hazardous conditions. In spite of this, it is not always possible to eliminate all potential hazards. The assembler of the machine must inform the final user about the residual risks.
 - The Safe torque off diagnostics are not available during power outages, or when the drive is only powered by the BAPO-xx auxiliary power extension module.
-

Maintenance

After the operation of the circuit is validated at start-up, the STO function shall be maintained by periodic proof testing. In high demand mode of operation, the maximum proof test interval is 20 years. In low demand mode of operation, the maximum proof test interval is 5 or 2 years; see section [Safety data \(page 161\)](#). It is assumed that all dangerous failures of the STO circuit are detected by the proof test. To perform the proof test, do the [Acceptance test procedure \(page 156\)](#).

Note: See also the Recommendation of Use CNB/M/11.050 (published by the European co-ordination of Notified Bodies) concerning dual-channel safety-related systems with electromechanical outputs:

- When the safety integrity requirement for the safety function is SIL 3 or PL e (cat. 3 or 4), the proof test for the function must be performed at least every month.
- When the safety integrity requirement for the safety function is SIL 2 (HFT = 1) or PL d (cat. 3), the proof test for the function must be performed at least every 12 months.

The STO function of the drive does not contain any electromechanical components.

In addition to proof testing, it is a good practice to check the operation of the function when other maintenance procedures are carried out on the machinery.

Include the Safe torque off operation test described above in the routine maintenance program of the machinery that the drive runs.

If any wiring or component change is needed after start up, or the parameters are restored, do the test given in section [Acceptance test procedure \(page 156\)](#).

Use only spare parts approved by ABB.

Record all maintenance and proof test activities in the machine logbook.

■ Competence

The maintenance and proof test activities of the safety function must be carried out by a competent person with adequate expertise and knowledge of the safety function as well as functional safety, as required by IEC 61508-1 clause 6.

Fault tracing

The indications given during the normal operation of the Safe torque off function are selected by drive control program parameter 31.22.

The diagnostics of the Safe torque off function cross-compare the status of the two STO channels. In case the channels are not in the same state, a fault reaction function is performed and the drive trips on an “STO hardware failure” fault. An attempt to use the STO in a non-redundant manner, for example activating only one channel, will trigger the same reaction.

See the firmware manual of the drive control program for the indications generated by the drive, and for details on directing fault and warning indications to an output on the control unit for external diagnostics.

Any failures of the Safe torque off function must be reported to ABB.

Safety data

The safety data for the Safe torque off function is given below.

Note: The safety data is calculated for redundant use, and does not apply if both STO channels are not used.

Frame size	SIL/ SILCL	PL	SFF (%)	PFH ($T_1 = 20$ a) (1/h)	PFD _{avg} ($T_1 = 2$ a)	PFD _{avg} ($T_1 = 5$ a)	MTTF _D (a)	DC (%)	Cat.	SC	HFT	CCF	T _M (a)
3-phase $U_N = 380...480$ V													
R1	3	e	>90	8.00E-09	6.68E-05	1.67E-04	2568	≥90	3	3	1	80	20
R2	3	e	>90	8.00E-09	6.68E-05	1.67E-04	2568	≥90	3	3	1	80	20
R3	3	e	>90	8.00E-09	6.68E-05	1.67E-04	2569	≥90	3	3	1	80	20
R4	3	e	>90	8.00E-09	6.68E-05	1.67E-04	2568	≥90	3	3	1	80	20
3AXD10000320081 D													

- The following temperature profile is used in safety value calculations:
 - 670 on/off cycles per year with $\Delta T = 71.66$ °C
 - 1340 on/off cycles per year with $\Delta T = 61.66$ °C
 - 30 on/off cycles per year with $\Delta T = 10.0$ °C
 - 32 °C board temperature at 2.0% of time
 - 60 °C board temperature at 1.5% of time
 - 85 °C board temperature at 2.3% of time.
- The STO is a type A safety component as defined in IEC 61508-2.
- Relevant failure modes:
 - The STO trips spuriously (safe failure)
 - The STO does not activate when requested
 - A fault exclusion on the failure mode “short circuit on printed circuit board” has been made (EN 13849-2, table D.5). The analysis is based on an assumption that one failure occurs at one time. No accumulated failures have been analyzed.
- STO response times:
 - STO reaction time (shortest detectable break): 1 ms
 - STO response time: 5 ms (typical), 12 ms (maximum)
 - Fault detection time: Channels in different states for longer than 200 ms
 - Fault reaction time: Fault detection time + 10 ms
- Indication delays:
 - STO fault indication (parameter 31.22) delay: < 500 ms
 - STO warning indication (parameter 31.22) delay: < 1000 ms

■ Abbreviations

Abbr.	Reference	Description
Cat.	EN ISO 13849-1	Classification of the safety-related parts of a control system in respect of their resistance to faults and their subsequent behavior in the fault condition, and which is achieved by the structural arrangement of the parts, fault detection and/or by their reliability. The categories are: B, 1, 2, 3 and 4.
CCF	EN ISO 13849-1	Common cause failure (%)

Abbr.	Reference	Description
DC	EN ISO 13849-1	Diagnostic coverage
HFT	IEC 61508	Hardware fault tolerance
MTTF _D	EN ISO 13849-1	Mean time to dangerous failure: (Total number of life units) / (Number of dangerous, undetected failures) during a particular measurement interval under stated conditions
PFD _{avg}	IEC 61508	Average probability of dangerous failure on demand, that is, mean unavailability of a safety-related system to perform the specified safety function when a demand occurs
PFH	IEC 61508	Average frequency of dangerous failures per hour, that is, average frequency of a dangerous failure of a safety related system to perform the specified safety function over a given period of time
PL	EN ISO 13849-1	Performance level. Levels a...e correspond to SIL
SC	IEC 61508	Systematic capability
SFF	IEC 61508	Safe failure fraction (%)
SIL	IEC 61508	Safety integrity level (1...3)
SILCL	IEC/EN 62061	Maximum SIL (level 1...3) that can be claimed for a safety function or subsystem
STO	IEC/EN 61800-5-2	Safe torque off
T ₁	IEC 61508-6	Proof test interval. T ₁ is a parameter used to define the probabilistic failure rate (PFH or PFD) for the safety function or subsystem. Performing a proof test at a maximum interval of T ₁ is required to keep the SIL capability valid. The same interval must be followed to keep the PL capability (EN ISO 13849) valid. See also section Maintenance.
T _M	EN ISO 13849-1	Mission time: the period of time covering the intended use of the safety function/device. After the mission time elapses, the safety device must be replaced. Note that any T _M values given cannot be regarded as a guarantee or warranty.

■ TÜV certificate

The TÜV certificate is available on the Internet at www.abb.com/drives/documents.

■ Declaration of conformity



EU Declaration of Conformity

Machinery Directive 2006/42/EC

We

Manufacturer: ABB Oy
Address: Hiomotie 13, 00380 Helsinki, Finland.
Phone: +358 10 22 11

declare under our sole responsibility that the following product:

Frequency converter
ACS480-04

with regard to the safety function

Safe torque off

is in conformity with all the relevant safety component requirements of EU Machinery Directive 2006/42/EC, when the listed safety function is used for safety component functionality.

The following harmonized standards have been applied:

EN 61800-5-2:2007	<i>Adjustable speed electrical power drive systems – Part 5-2: Safety requirements - Functional</i>
EN 62061:2005 + AC:2010 + A1:2013 + A2:2015	<i>Safety of machinery – Functional safety of safety-related electrical, electronic and programmable electronic control systems</i>
EN ISO 13849-1:2015	<i>Safety of machinery – Safety-related parts of control systems. Part 1: General requirements</i>
EN ISO 13849-2:2012	<i>Safety of machinery – Safety-related parts of the control systems. Part 2: Validation</i>
EN 60204-1: 2006 + A1:2009 + AC:2010	<i>Safety of machinery – Electrical equipment of machines – Part 1: General requirements</i>

The following other standards have been applied:

IEC 61508:2010	Functional safety of electrical / electronic / programmable electronic safety-related systems
IEC 61800-5-2:2016	Adjustable speed electrical power drive systems – Part 5-2: Safety requirements - Functional

The product[s] referred in this Declaration of conformity fulfil[s] the relevant provisions of other European Union Directives which are notified in Single EU Declaration of conformity 3AXD10000594967.

Person authorized to compile the technical file:

Name and address: Risto Mynttinen, Hiomotie 13, 00380 Helsinki, Finland.

Helsinki, 9 Feb 2018

Manufacturer representative:

Vesa Kandell
Vice President, ABB

14

BAPO-01 auxiliary power extension module

Contents of this chapter

This chapter contains a description and technical data of the optional BAPO-01 auxiliary power extension module.

Safety instructions



WARNING!

Obey the safety instructions of the drive. If you ignore them, injury or death, or damage to the equipment can occur.

Hardware description

The BAPO-01 auxiliary power extension module (option +L534) enables the use of an external 24 V DC power supply with the drive. An external power supply is used to keep the drive control board energized during a drive power outage.

The BAPO-01 module has internal connections to provide back-up power to the control board (I/O, fieldbus). There is a DC to DC flyback converter power supply inside the module. This power supply takes 24 V DC as input and outputs 5 V DC to the control board to keep the processor and communication links on at all times.

Note: The BAPO-01 is not a battery. It only enables the use of an external power supply.

If you change drive parameters when the control board is energized by the BAPO-01 module, force parameter saving by setting the value of parameter *96.07 PARAM SAVE* to (1) *SAVE*. Otherwise, changed data will not be saved.

■ Layout

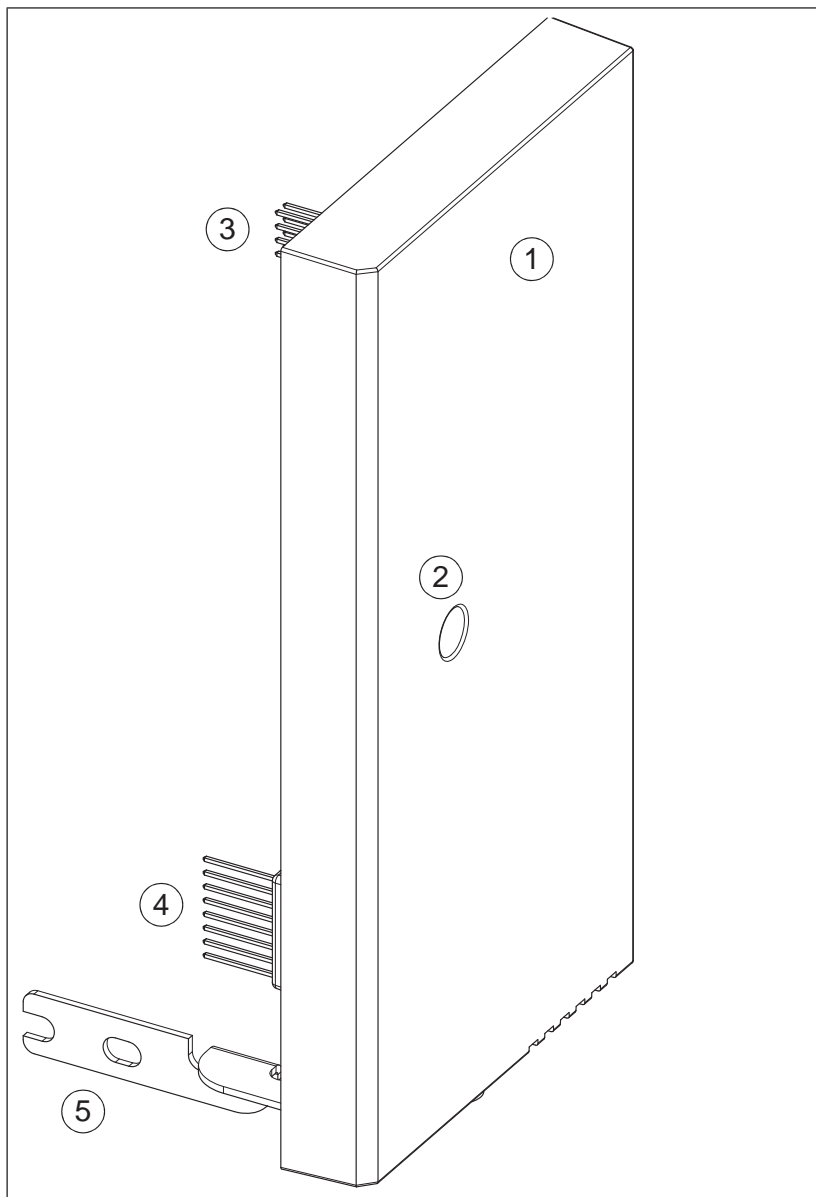

1. BAPO-01 module
2. Locking screw hole
3. Internal X100 connector
4. Internal X102 connector
5. Grounding rail

Mechanical installation

See the electrical installation instructions of the drive.

Electrical installation

Connect the external power supply to the +24 V and DGND terminals on the drive. See the electrical installation instructions of the drive.

Do not chain an external 24 V DC power supply to several drives. Each drive must be powered by a single 24 V DC power supply, or a separate 24 V DC output of one auxiliary power source.

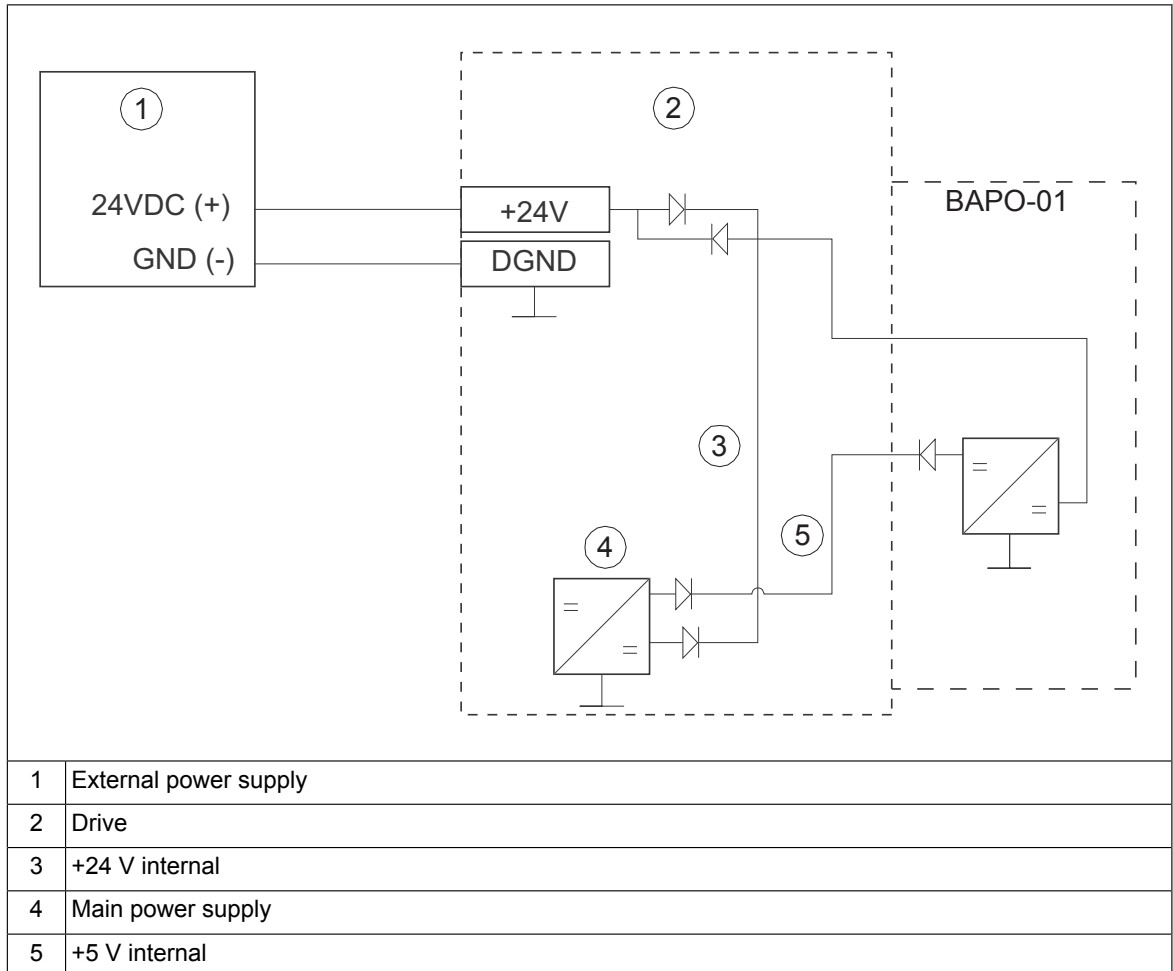

Start-up

To configure the BAPO-01 module:

1. Power up the drive.
2. Set the parameter *95.04 Control board supply* to 1 (*External 24V*).

Technical data

Voltage and current rating for the auxiliary power supply: +24 V DC $\pm 10\%$, max. 1000 mA (including internal fan load).

Power loss: Power losses with maximum load 4 W.

168 BAPO-01 auxiliary power extension module

Dimensions:

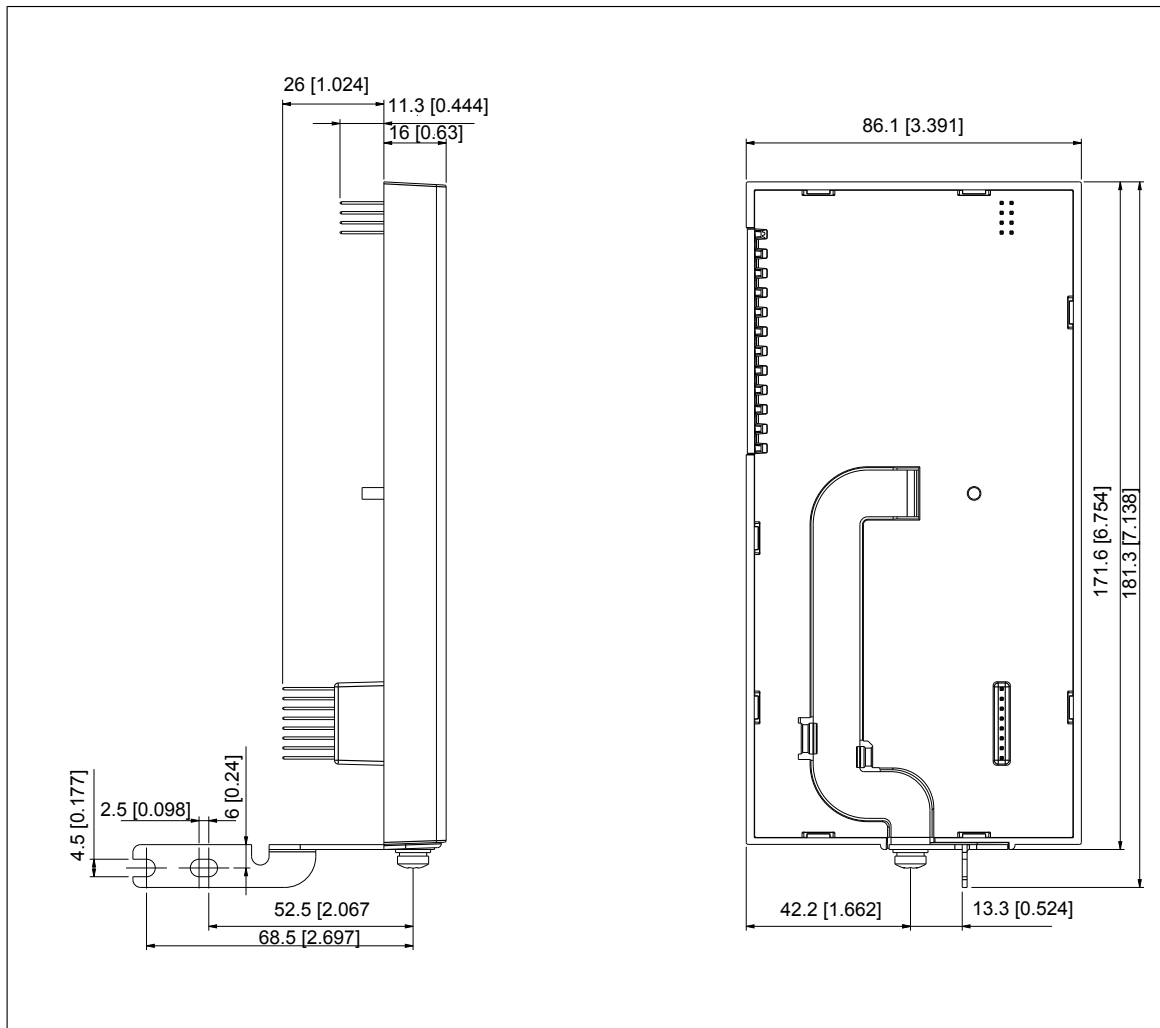

15

BIO-01 I/O extension module

Contents of this chapter

This chapter contains a description and technical data of the optional BIO-01 I/O extension module.

Safety instructions

**WARNING!**

Obey the safety instructions of the drive. If you ignore them, injury or death, or damage to the equipment can occur.

Hardware description

■ Product overview

The BIO-01 option module (option +L515) is an I/O extension module to be used with fieldbus adapter module. The BIO-01 module can be installed between the drive and the fieldbus module.

The BIO-01 has three additional digital inputs (DI3, DI4 and DI5), one analog input (AI1) and one digital output DO1 that is referred as DIO1 in the firmware (but works only in output mode). You can use DI4 and DI5 as frequency inputs and DO1 as a frequency output.

■ Layout

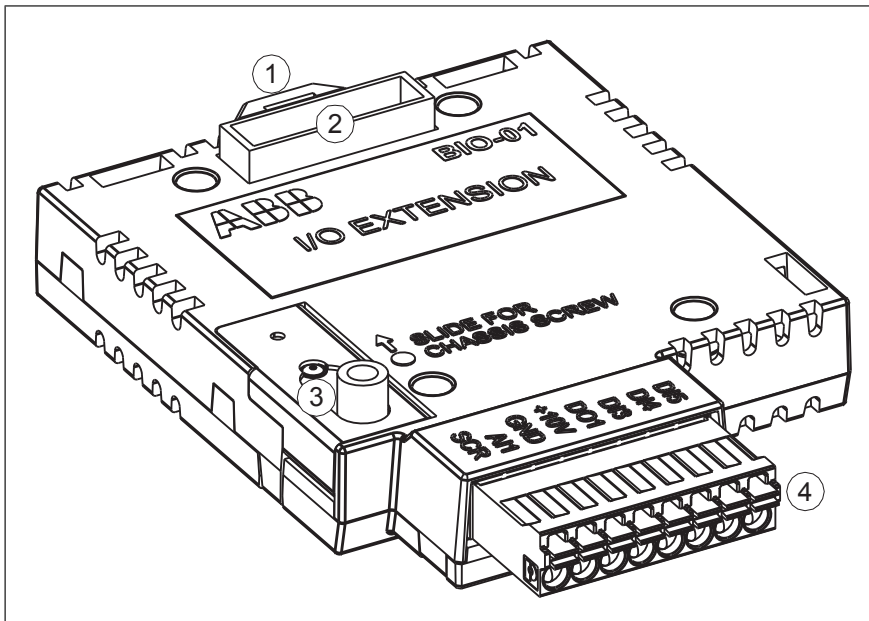

1. Locking tab
2. Option module slot
3. Chassis screw
4. I/O connector

Mechanical installation

See the electrical installation instructions of the drive.

Before you install the BIO-01 option module, make sure that the chassis screw slider is in the top position. After the option module is installed, tighten the chassis screw and move the slider to the bottom position.

The BIO-01 option module kit comes with a higher cable clamp plate. Use this cable clamp plate to ground the wires that connect to the BIO-01 option module.

Electrical installation

The BIO-01 module has removable spring clamp terminals. Use ferrules on the multistranded conductor ends.

The connection diagram below is valid for the drive equipped with the BIO-01 I/O extension module when the ABB standard macro is selected (parameter 96.04).

The last column indicates the terminal location: × = base unit, blank = BIO-01 module.

Connection	Terminal	Description	
	+24 V	Auxiliary voltage output +24 V DC, max. 250 mA	×
	DGND	Auxiliary voltage output common	×
	DCOM	Digital input common for all	×
	DI1	Stop (0) / Start (1)	×
	DI2	Forward (0) / Reverse (1)	×
	DI3	Constant frequency/speed selection	
	DI4	Constant frequency/speed selection	
	DI5	Ramp set 1 (0) / Ramp set 2 (1)	
	DIO1	Not configured	
	AI1	Output frequency/speed ref: 0...10 V DC	
	+10V	Reference voltage +10 V DC (max. 10 mA)	
	GND	Analog circuit common / DO common	
	SCR	Signal cable shield	
	SGND	Safe torque off. Both IN1 AND IN2 circuits must be closed for the drive to start. (Factory connection.)	
	IN1		×
	IN2		×
	OUT1		×

Start-up

The BIO-01 module is automatically identified by the drive firmware. To configure the inputs, refer to the drive firmware manual.

Technical data

Control connection data: Spring type terminal blocks. Conductor size accepted by the terminals: 0.2...1.5 mm² (24...16 AWG). Exception: max. 0.75 mm² (18 AWG) for a multistranded conductor with a ferrule and plastic sleeve.

Internal connections of GND and SCR terminals:

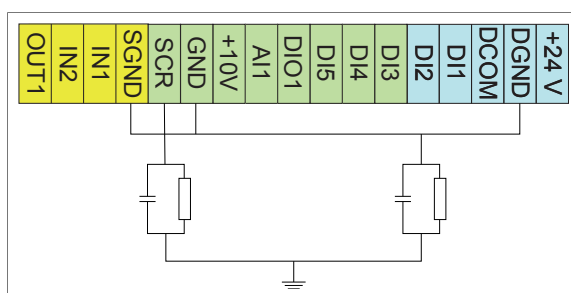

Dimensions:

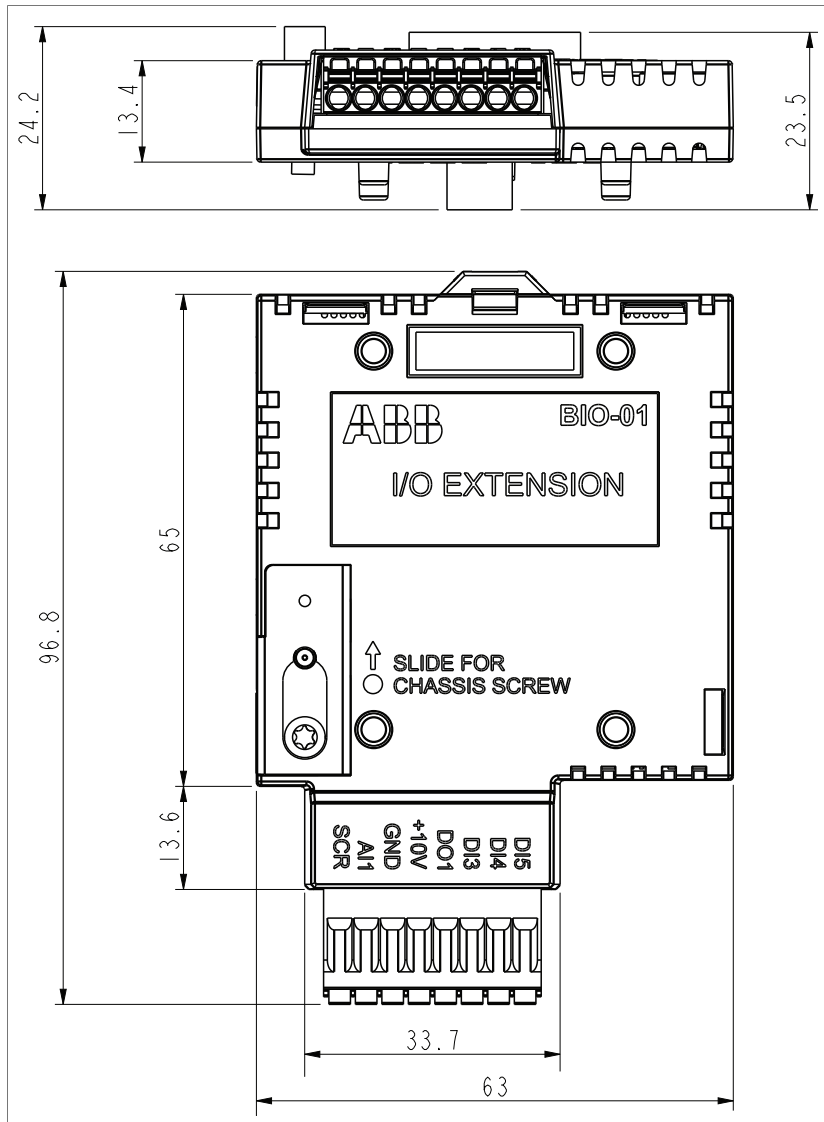

16

BREL-01 relay output extension module

Contents of this chapter

This chapter contains a description and technical data of the optional BREL-01 relay output extension module.

Safety instructions



WARNING!

Obey the safety instructions of the drive. If you ignore them, injury or death, or damage to the equipment can occur.

Hardware description

- **Product overview**

BREL-01 relay output extension module (option +L511) adds four relay outputs to the drive.

Layout

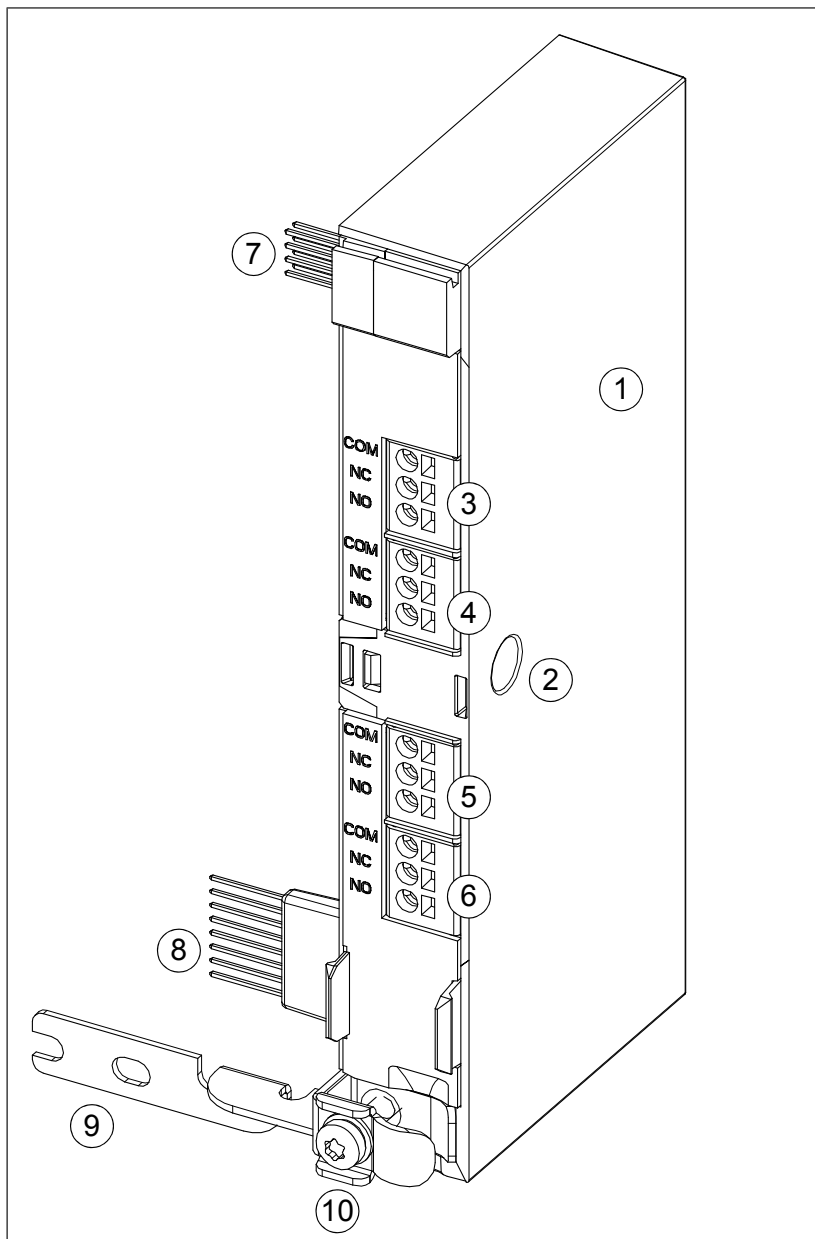

1. BREL-01 module
2. Locking screw hole
3. X103 connector
4. X104 connector
5. X105 connector
6. X106 connector
7. Internal X100 connector
8. Internal X102 connector
9. Grounding rail
10. Grounding screw

Mechanical installation

See the electrical installation instructions of the drive.

Electrical installation

Use 0.5 to 2.5 mm² (20 to 14 AWG) cable with a sufficient voltage rating.

If you connect an inductive load (relay or contactor coil, motor) protect the relay contacts with varistor, RC filter (AC) or diode (DC). Install the protective component as close to the inductive load as possible. Do not install protective components at the relay output terminals.

Identification		Description	
X103			Max. switching voltage: 250 V AC / 30 V DC Max. switching current: 2 A Galvanically isolated.
1	COM	Common	
2	NC	Normally closed	
3	NO	Normally open	
X104			
1	COM	Common	
2	NC	Normally closed	
3	NO	Normally open	
X105			
1	COM	Common	
2	NC	Normally closed	
3	NO	Normally open	
X106			
1	COM	Common	
2	NC	Normally closed	
3	NO	Normally open	

Start-up

To configure the operation of the relays added with the BREL-01 module:

1. Power up the drive.
2. Set the parameter *15.01 Extension module type* to 5 (BREL)..
3. Use the control panel on the drive and set the parameters for relay outputs 2 to 5 in *15 I/O extension module*. Refer to the *ACS480 standard control program firmware manual* (3AXD50000047399 [English]) for parameter descriptions. .

Configuration parameters

The configuration parameters of the BREL-01 module are in group *15 I/O extension module*.

No.	Name/Value	Description	Def / FbEq16/32
15 I/O extension module			
15.01	Extension module type	Sets the connected side-mounted extension module.	None
	BREL	Basenut relay extension module	5
15.02	Detected extension module	I/O extension module detected on the drive.	None
	BREL	Basenut relay extension module	5
15.04	RO status	Status of the relay outputs.	1=1
	Bit 0 RO2	Relay 2 output status. 1 = open / 0 = closed	
	Bit 1 RO3	Relay 3 output status. 1 = open / 0 = closed	
	Bit 2 RO4	Relay 4 output status. 1 = open / 0 = closed	
	Bit 3 RO5	Relay 5 output status. 1 = open / 0 = closed	
15.05	RO force selection	Selection of relay outputs for forcing.	1=1

176 BREL-01 relay output extension module

No.	Name/Value	Description	Def / FbEq16/32
	Bit 0 RO2	Relay 2 output status. 1 = selected to force / 0 = normal	
	Bit 1 RO3	Relay 3 output status. 1 = selected to force / 0 = normal	
	Bit 2 RO4	Relay 4 output status. 1 = selected to force / 0 = normal	
	Bit 3 RO5	Relay 5 output status. 1 = selected to force / 0 = normal	
15.06	RO forced data	Relay output forcing.	1=1
	Bit 0 RO2	Relay 2 output status. 1 = open / 0 = closed	
	Bit 1 RO3	Relay 3 output status. 1 = open / 0 = closed	
	Bit 2 RO4	Relay 4 output status. 1 = open / 0 = closed	
	Bit 3 RO5	Relay 5 output status. 1 = open / 0 = closed	
15.07	RO2 source	Relay output 2 source selection.	
		Relay output 2 is open.	0
		Relay output 2 is closed	1
		For complete parameter list, refer to the drive firmware manual.	...
15.08	RO2 ON delay	Sets the activation delay for relay output 2.	0.0 s
	0.0...3000.0 s	Activation delay for relay output 2.	10=1 s
15.09	RO2 OFF delay	Sets the deactivation delay for relay output 2.	0.0 s
	0.0...3000.0 s	Deactivation delay for relay output 2.	10=1 s
15.10	RO3 source	Relay output 3 source selection.	
		Relay output 3 is open.	0
		Relay output 3 is closed.	1
		For complete parameter list, refer to the drive firmware manual.	...
15.11	RO3 ON delay	Sets the activation delay for relay output 3.	0.0 s
	0.0...3000.0 s	Activation delay for relay output 3.	10=1 s
15.12	RO3 OFF delay	Sets the deactivation delay for relay output 3.	0.0 s
	0.0...3000.0 s	Deactivation delay for relay output 3.	10=1 s
15.13	RO4 source	Relay output 4 source selection.	
		Relay output 4 is open.	0
		Relay output 4 is closed.	1
		For complete parameter list, refer to the drive firmware manual.	...
15.14	RO4 ON delay	Sets the activation delay for relay output 4.	0.0 s
	0.0...3000.0 s	Activation delay for relay output 4.	10=1 s
15.15	RO4 OFF delay	Sets the deactivation delay for relay output 4.	0.0 s
	0.0...3000.0 s	Deactivation delay for relay output 4.	10=1 s
15.16	RO5 source	Relay output 5 source selection.	
		Relay output 5 is open.	0
		Relay output 5 is closed	1
		For complete parameter list, refer to the drive firmware manual.	...
15.17	RO5 ON delay	Sets the activation delay for relay output 5.	0.0 s
	0.0...3000.0 s	Activation delay for relay output 5.	10=1 s
15.18	RO5 OFF delay	Sets the deactivation delay for relay output 5.	0.0 s
	0.0...3000.0 s	Deactivation delay for relay output 5.	10=1 s

Technical data

External connectors: Four 3-pin (1×3) spring-clamp type terminal blocks, tin plated, 2.5 mm² wire size, pitch 5.0 mm.

Internal connectors: Connector X102 provides relay control signals from the control board: 1×8 pin header, pitch 2.54 mm, height 33.53 mm. Connector X100 is not in use in BREL-01: 2×4 pin header, pitch 2.54 mm, height 15.75 mm.

Dimensions:

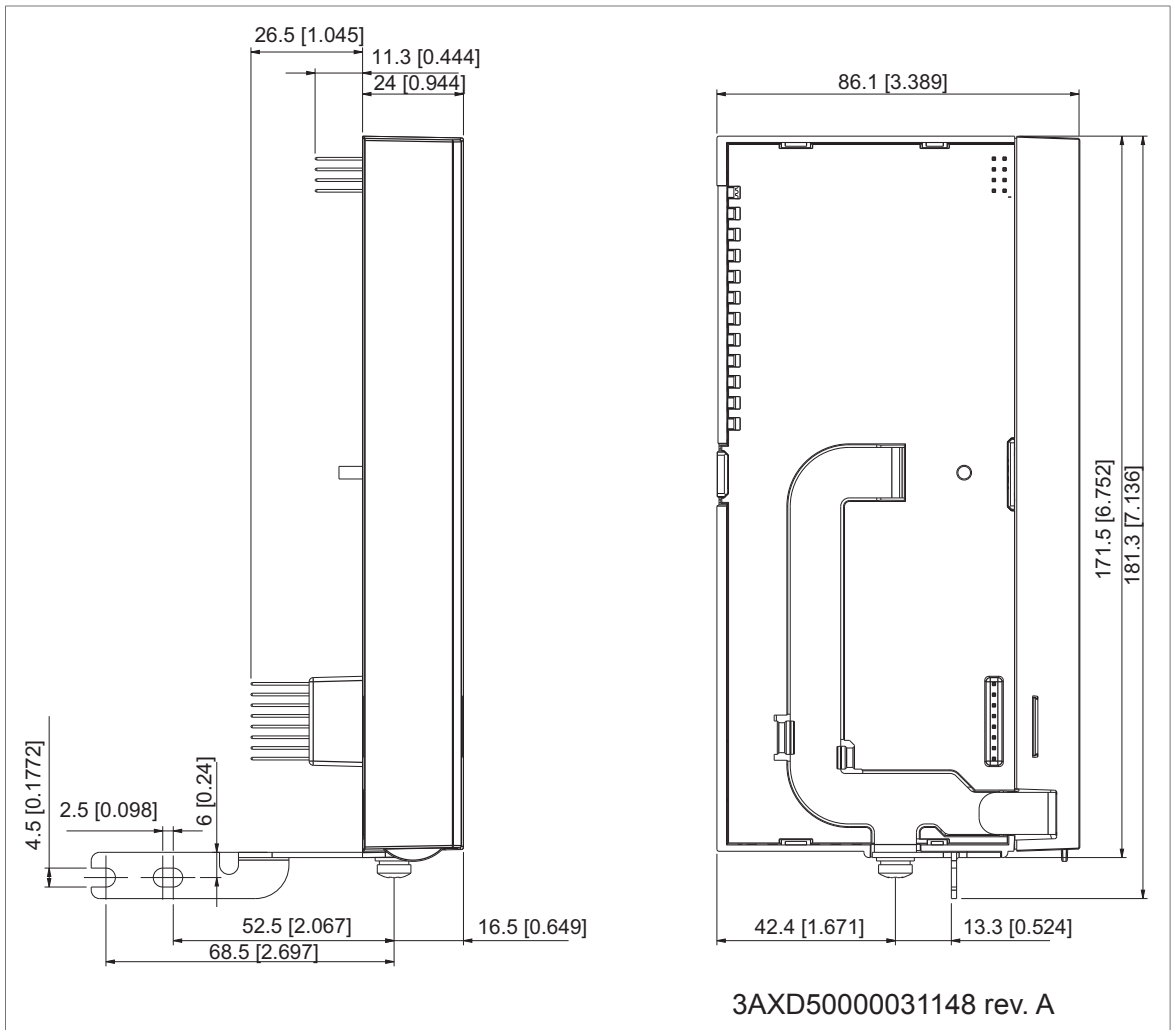



Further information

Product and service inquiries

Address any inquiries about the product to your local ABB representative, quoting the type designation and serial number of the unit in question. A listing of ABB sales, support and service contacts can be found by navigating to www.abb.com/searchchannels.

Product training

For information on ABB product training, navigate to new.abb.com/service/training.

Providing feedback on ABB manuals

Your comments on our manuals are welcome. Navigate to new.abb.com/drives/manuals-feedback-form.

Document library on the Internet

You can find manuals and other product documents in PDF format on the Internet at www.abb.com/drives/documents.



www.abb.com/drives



3AXD50000047392D