

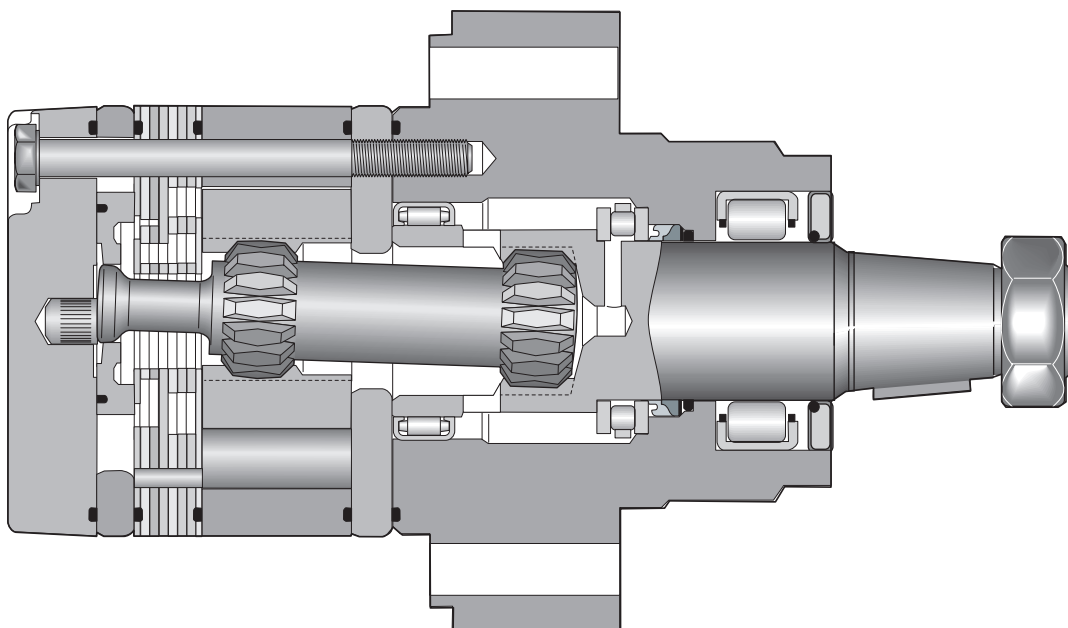

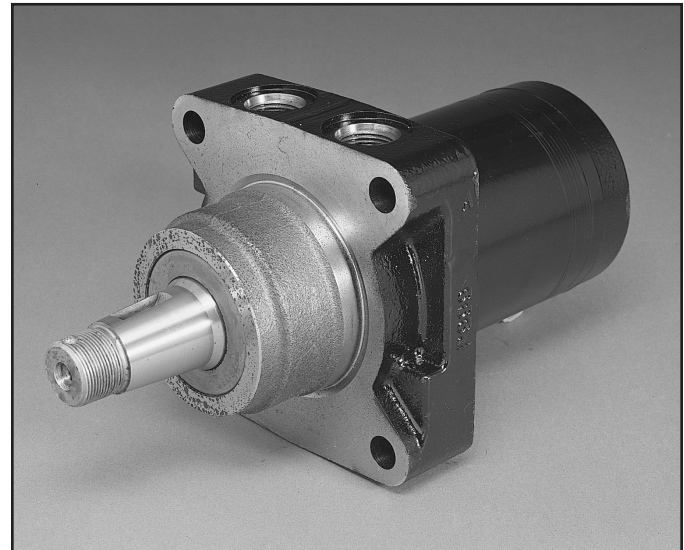

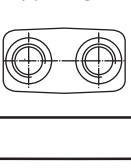

14 Displacements 14 Schluckvolumen 14 Cylindrée 14 Desplazamientos	(2.5 – 24.0 in ³ /rev) 41 . . . 390 cm ³ /rev	
Maximum Pressure Eingangsdruck Pression entrée Presion Maxima	Cont (2030 psid) . . .140 bar	Int (2750 psid) . . .190 bar
Maximum Oil Flow Schluckstrom Débit d'huile Caudal Maximo de Aceite	(20 gpm) . . . 75 lpm	
Maximum Speed Drehzahl Vitesse de rotation Maxi Velocidad Maxima	(1024 rpm) 1024 rpm	
Maximum Torque Max Drehmoment Couple Maxi Torque Maximo	Cont (4139 lb in) 467 Nm	Int (5728 lb in) 648 Nm
Maximum Side Load at Key Seitenlast Charges latérales Carga Maxima Lateral	(3150 lb) . . . 14000 N	

The Ultimate in Performance from a Light Duty Wheel Motor

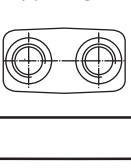
The TJ Series marries the TE Series drive train with a larger and heavier roller bearing and shaft. It provides all that could be expected of a light duty wheel motor and more. Unique 60:40 spline geometry provides drivetrain strength for severe applications. Roller vanes and sealed orbit commutation assure high volumetric efficiency and smooth slow speed operation. Cooling fluid flow across splines and seals mean long, trouble-free life.

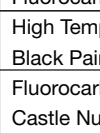
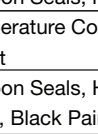
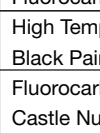
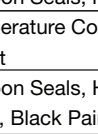
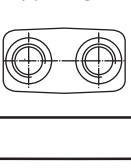

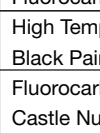
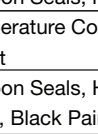
TJ	XXXX	U	S	08	0	XXXX																																																																																																																					
Series	Displacement Schluckvolumen Cylindrée Desplazamiento	Mounting Gehäuse Carter Montaje	Ports Anschluß Plan de raccordement Lumbreras	Shaft Welle Arbre Eje	Rotation Drehrichtung Direction de rotation Rotacion	Options Opciones																																																																																																																					
<table border="1" style="width: 100%; border-collapse: collapse;"> <thead> <tr> <th>Code</th> <th>cm³/tr cm³/giro</th> <th>in³/rev</th> </tr> </thead> <tbody> <tr><td>0036</td><td>36 / 2.2</td><td></td></tr> <tr><td>0045</td><td>41 / 2.5</td><td></td></tr> <tr><td>0050</td><td>49 / 3.0</td><td></td></tr> <tr><td>0065</td><td>65 / 4.0</td><td></td></tr> <tr><td>0080</td><td>82 / 5.0</td><td></td></tr> <tr><td>0100</td><td>98 / 6.0</td><td></td></tr> <tr><td>0130</td><td>130 / 8.0</td><td></td></tr> <tr><td>0165</td><td>163 / 10.0</td><td></td></tr> <tr><td>0195</td><td>195 / 11.9</td><td></td></tr> <tr><td>0230</td><td>228 / 13.9</td><td></td></tr> <tr><td>0260</td><td>260 / 15.9</td><td></td></tr> <tr><td>0295</td><td>293 / 17.9</td><td></td></tr> <tr><td>0330</td><td>328 / 20.0</td><td></td></tr> <tr><td>0365</td><td>370 / 22.6</td><td></td></tr> <tr><td>0390</td><td>392 / 24.0</td><td></td></tr> </tbody> </table>	Code	cm ³ /tr cm ³ /giro	in ³ /rev	0036	36 / 2.2		0045	41 / 2.5		0050	49 / 3.0		0065	65 / 4.0		0080	82 / 5.0		0100	98 / 6.0		0130	130 / 8.0		0165	163 / 10.0		0195	195 / 11.9		0230	228 / 13.9		0260	260 / 15.9		0295	293 / 17.9		0330	328 / 20.0		0365	370 / 22.6		0390	392 / 24.0		<table border="1" style="width: 100%; border-collapse: collapse;"> <thead> <tr> <th>Code</th> <th>Mounting</th> </tr> </thead> <tbody> <tr> <td style="text-align: center;">U</td> <td>Wheel Mount </td> </tr> </tbody> </table> <table border="1" style="width: 100%; border-collapse: collapse;"> <thead> <tr> <th>Code</th> <th>Porting</th> </tr> </thead> <tbody> <tr> <td style="text-align: center;">S</td> <td>7/8-14 SAE </td> </tr> </tbody> </table> <table border="1" style="width: 100%; border-collapse: collapse;"> <thead> <tr> <th>Code</th> <th>Shaft</th> </tr> </thead> <tbody> <tr> <td style="text-align: center;">08</td> <td>1 1/4" Tapered* </td> </tr> </tbody> </table> <p style="font-size: small;">*See installation instructions.</p>	Code	Mounting	U	Wheel Mount 	Code	Porting	S	7/8-14 SAE 	Code	Shaft	08	1 1/4" Tapered* 	<table border="1" style="width: 100%; border-collapse: collapse;"> <thead> <tr> <th>Code</th> <th>Rotation</th> </tr> </thead> <tbody> <tr> <td style="text-align: center;">0</td> <td>Standard </td> </tr> <tr> <td style="text-align: center;">1</td> <td>Reverse Timed Manifold </td> </tr> </tbody> </table>	Code	Rotation	0	Standard 	1	Reverse Timed Manifold 	<table border="1" style="width: 100%; border-collapse: collapse;"> <thead> <tr> <th>Code</th> <th>Options</th> </tr> </thead> <tbody> <tr><td>AAAA</td><td>Black Paint</td></tr> <tr><td>AAAB</td><td>No Paint</td></tr> <tr><td>AAAF</td><td>Castle Nut, Black Paint</td></tr> <tr><td>AABP</td><td>Castle Nut, No Paint</td></tr> <tr><td>AAAG</td><td>Fluorocarbon Seals, Black Paint</td></tr> <tr><td>AAAH</td><td>Fluorocarbon Seals, No Paint</td></tr> <tr><td>AAAJ</td><td>High Temperature Commutator Seal, Black Paint</td></tr> <tr><td>AAFG</td><td>High Temperature Commutator Seal, No Paint</td></tr> <tr><td>AABJ¹</td><td>Free Running Rotorset, Black Paint</td></tr> <tr><td>AABK¹</td><td>Free Running Rotorset, No Paint</td></tr> <tr><td>AAFW</td><td>High Temperature Commutator Seals, Fluorocarbon Seals, Black Paint</td></tr> <tr><td>AAFA</td><td>High Temperature Commutator Seals, Fluorocarbon Seals, No Paint</td></tr> <tr><td>AAFB</td><td>High Temperature Commutator Seals, Castle Nut, Black Paint</td></tr> <tr><td>AANG</td><td>Fluorocarbon Seals, High Temp Commutator Seals, Castle Nut, Black Paint</td></tr> <tr><td>BBDF</td><td>761 PSI/53 Bar Int Bidirectional Relief, Black Paint</td></tr> <tr><td>BBDM</td><td>761 PSI/53 Bar Int Bidirectional Relief, No Paint</td></tr> <tr><td>BBCV</td><td>921 PSI/64 Bar Int Bidirectional Relief, Black Paint</td></tr> <tr><td>BBGA</td><td>1200 PSI/83 Bar Int Bidirectional Relief, Black Paint</td></tr> <tr><td>BBCM</td><td>1200 PSI/83 Bar Int Bidirectional Relief, No Paint</td></tr> <tr><td>BBCR</td><td>1450 PSI/100 Bar Int Bidirectional Relief, Black Paint</td></tr> <tr><td>BBCP</td><td>1450 PSI/100 Bar Int Bidirectional Relief, No Paint</td></tr> <tr><td>BBCT</td><td>1560 PSI/108 Bar Int Bidirectional Relief, No Paint</td></tr> <tr><td>BBDY</td><td>1740 PSI/120 Bar Int Bidirectional Relief, Black Paint</td></tr> <tr><td>BBCK</td><td>1740 PSI/120 Bar Int Bidirectional Relief, No Paint</td></tr> <tr><td>BBFZ²</td><td>2030 PSI/140 Bar Bidirectional Relief, Black Paint</td></tr> <tr><td>BBCN²</td><td>2030 PSI/140 Bar Bidirectional Relief, No Paint</td></tr> </tbody> </table>	Code	Options	AAAA	Black Paint	AAAB	No Paint	AAAF	Castle Nut, Black Paint	AABP	Castle Nut, No Paint	AAAG	Fluorocarbon Seals, Black Paint	AAAH	Fluorocarbon Seals, No Paint	AAAJ	High Temperature Commutator Seal, Black Paint	AAFG	High Temperature Commutator Seal, No Paint	AABJ ¹	Free Running Rotorset, Black Paint	AABK ¹	Free Running Rotorset, No Paint	AAFW	High Temperature Commutator Seals, Fluorocarbon Seals, Black Paint	AAFA	High Temperature Commutator Seals, Fluorocarbon Seals, No Paint	AAFB	High Temperature Commutator Seals, Castle Nut, Black Paint	AANG	Fluorocarbon Seals, High Temp Commutator Seals, Castle Nut, Black Paint	BBDF	761 PSI/53 Bar Int Bidirectional Relief, Black Paint	BBDM	761 PSI/53 Bar Int Bidirectional Relief, No Paint	BBCV	921 PSI/64 Bar Int Bidirectional Relief, Black Paint	BBGA	1200 PSI/83 Bar Int Bidirectional Relief, Black Paint	BBCM	1200 PSI/83 Bar Int Bidirectional Relief, No Paint	BBCR	1450 PSI/100 Bar Int Bidirectional Relief, Black Paint	BBCP	1450 PSI/100 Bar Int Bidirectional Relief, No Paint	BBCT	1560 PSI/108 Bar Int Bidirectional Relief, No Paint	BBDY	1740 PSI/120 Bar Int Bidirectional Relief, Black Paint	BBCK	1740 PSI/120 Bar Int Bidirectional Relief, No Paint	BBFZ ²	2030 PSI/140 Bar Bidirectional Relief, Black Paint	BBCN ²	2030 PSI/140 Bar Bidirectional Relief, No Paint
Code	cm ³ /tr cm ³ /giro	in ³ /rev																																																																																																																									
0036	36 / 2.2																																																																																																																										
0045	41 / 2.5																																																																																																																										
0050	49 / 3.0																																																																																																																										
0065	65 / 4.0																																																																																																																										
0080	82 / 5.0																																																																																																																										
0100	98 / 6.0																																																																																																																										
0130	130 / 8.0																																																																																																																										
0165	163 / 10.0																																																																																																																										
0195	195 / 11.9																																																																																																																										
0230	228 / 13.9																																																																																																																										
0260	260 / 15.9																																																																																																																										
0295	293 / 17.9																																																																																																																										
0330	328 / 20.0																																																																																																																										
0365	370 / 22.6																																																																																																																										
0390	392 / 24.0																																																																																																																										
Code	Mounting																																																																																																																										
U	Wheel Mount 																																																																																																																										
Code	Porting																																																																																																																										
S	7/8-14 SAE 																																																																																																																										
Code	Shaft																																																																																																																										
08	1 1/4" Tapered* 																																																																																																																										
Code	Rotation																																																																																																																										
0	Standard 																																																																																																																										
1	Reverse Timed Manifold 																																																																																																																										
Code	Options																																																																																																																										
AAAA	Black Paint																																																																																																																										
AAAB	No Paint																																																																																																																										
AAAF	Castle Nut, Black Paint																																																																																																																										
AABP	Castle Nut, No Paint																																																																																																																										
AAAG	Fluorocarbon Seals, Black Paint																																																																																																																										
AAAH	Fluorocarbon Seals, No Paint																																																																																																																										
AAAJ	High Temperature Commutator Seal, Black Paint																																																																																																																										
AAFG	High Temperature Commutator Seal, No Paint																																																																																																																										
AABJ ¹	Free Running Rotorset, Black Paint																																																																																																																										
AABK ¹	Free Running Rotorset, No Paint																																																																																																																										
AAFW	High Temperature Commutator Seals, Fluorocarbon Seals, Black Paint																																																																																																																										
AAFA	High Temperature Commutator Seals, Fluorocarbon Seals, No Paint																																																																																																																										
AAFB	High Temperature Commutator Seals, Castle Nut, Black Paint																																																																																																																										
AANG	Fluorocarbon Seals, High Temp Commutator Seals, Castle Nut, Black Paint																																																																																																																										
BBDF	761 PSI/53 Bar Int Bidirectional Relief, Black Paint																																																																																																																										
BBDM	761 PSI/53 Bar Int Bidirectional Relief, No Paint																																																																																																																										
BBCV	921 PSI/64 Bar Int Bidirectional Relief, Black Paint																																																																																																																										
BBGA	1200 PSI/83 Bar Int Bidirectional Relief, Black Paint																																																																																																																										
BBCM	1200 PSI/83 Bar Int Bidirectional Relief, No Paint																																																																																																																										
BBCR	1450 PSI/100 Bar Int Bidirectional Relief, Black Paint																																																																																																																										
BBCP	1450 PSI/100 Bar Int Bidirectional Relief, No Paint																																																																																																																										
BBCT	1560 PSI/108 Bar Int Bidirectional Relief, No Paint																																																																																																																										
BBDY	1740 PSI/120 Bar Int Bidirectional Relief, Black Paint																																																																																																																										
BBCK	1740 PSI/120 Bar Int Bidirectional Relief, No Paint																																																																																																																										
BBFZ ²	2030 PSI/140 Bar Bidirectional Relief, Black Paint																																																																																																																										
BBCN ²	2030 PSI/140 Bar Bidirectional Relief, No Paint																																																																																																																										

For other available options, see pages 107-108.

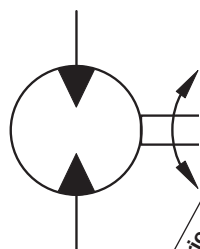

Geometric displacement
Geom. Schluckvolumen
Desplazamientos
Max. speed @ Max. intermittent flow
Max. Drehzahl intermittierender Betrieb:
Vitesse de rotation maxi
Velocidad maxima a caudal intermitente maximo
Max. oil flow
Max. Schluckstrom
Débit d'huile maxi
Caudal Maximo de Aceite
Max. Differential Pressure
Max. Druckgefälle
Chute de pression maxi
Presion diferencial maxima
Max. supply pressure
Max. Eingangsdruk
Presion maxi entréee
Presion maxima de alimentacion
Max. torque
Max. Drehmoment
Couple maxi
Torque Maximo
Max. performance
Max. Leistungabgabe
Maximo rendimiento
Min. starting torque
Min. Anlaufmoment
Couple min. fourni au dé manrage
Torque minimo de arranque

Motor Series TJ	cm ³ /rev in ³ /rev	Int rev/min	cont / int* l/min g/min	cont / int* bar psid	max bar psig	cont / int* Nm lb-in	max KW HP	cont / int* Nm lb-in
TJ 0036	36 2.2	1141	34 42 9 11	140 190 2030 2750	200 2900	54.6 71.1 483 630	8.5 11.4	44 52 389 460
TJ 0045	41 2.5	1024	34 42 9 11	140 190 2030 2750	200 2900	71 99 624 876	10.4 13.9	44 64 411 565
TJ 0050	49 3.0	1020	34 50 9 13	140 190 2030 2750	200 2900	90 127 796 1120	12.8 17.2	72 98 637 871
TJ 0065	65 4.0	877	45 57 12 15	140 190 2030 2750	200 2900	125 176 1106 1558	14.7 19.8	100 137 885 1211
TJ 0080	82 5.0	695	45 57 12 15	140 190 2030 2750	200 2900	160 220 1416 1947	17.3 23.2	128 171 1133 1515
TJ 0100	98 6.0	582	45 57 12 15	140 190 2030 2750	200 2900	190 264 1682 2337	17.4 23.4	152 205 1345 1819
TJ 0130	130 8.0	438	45 57 12 15	140 190 2030 2750	200 2900	255 352 2257 3116	17.3 23.2	204 274 1806 2423
TJ 0165	163 10.0	348	45 57 12 15	140 190 2030 2750	200 2900	310 436 2744 3846	17.0 22.8	248 338 2195 2992
TJ 0195	195 11.9	292	45 57 12 15	140 190 2030 2750	200 2900	390 528 3452 4673	17.4 23.4	312 411 2762 3637
TJ 0230	228 13.9	328	57 75 15 20	120 165 1740 2400	200 2900	380 514 3363 4554	17.7 23.8	304 411 2691 3637
TJ 0260	260 15.9	287	57 75 15 20	110 155 1595 2250	200 2900	400 550 3540 4870	16.7 22.4	320 449 2832 3977
TJ 0295	293 17.9	256	57 75 15 20	100 145 1450 2100	200 2900	428 582 3784 5180	15.7 21.0	328 445 2903 3939
TJ 0330	328 20.0	228	57 75 15 20	100 135 1450 1950	200 2900	443 600 3926 5312	14.8 19.8	344 453 3045 4014
TJ 0365	370 22.6	203	57 75 15 20	95 125 1378 1825	200 2900	467 648 4133 5728	13.6 18.2	373 477 3301 4223
TJ 0390	392 24.0	191	57 75 15 20	85 120 1233 1740	200 2900	445 628 3935 5562	12.5 16.8	348 462 3080 4090

Performance data based on testing using 10W40 oil with a viscosity of 43,1 cSt. (200 SUS) at 54° C (130° F). Performance data is typical. Actual data may vary slightly from one production motor to another.

Les donnees sur les performances sont basees sur des tests utilisant de l'huile 10W40 d'une viscosite de 200 SUS a 54°C (130°F). Ces donnees correspondent a des situations typiques. Les donnees reelles peuvent varier legerement d'un moteur de production a l'autre.

Leistungsdaten sind gemessen mit SAE 10W40 bei einer Viskositat von 43,1 Cst bei 54°C. Geringfuegige Abweichungen von den Katalogdaten sind moeglich.

Datos tecnicos obtenidos con aceite 10W40 de 200 SUS de viscosidad a 54°C (130°F). Los datos proporcionados son valores tipcos. Los valores exactos reales podrian tener una pequena variacion entre distintos motores.

* Intermittent operation rating applies to 10% of every minute.
Intermittierende Werte maximal 10% von jeder Betriebsminute.
Fonctionnement interm. 10% max. de chaque minute d'utilisation.
Capacidad de funcionamiento intermitente valida para 10% por cada minuto.

TJ 0036 **2.2 cu in / rev** PRESSURE (PSID)

	500	1000	1500	2000	2750
.5	111	225	346	470	
	44	37	25	15	
1	113	231	353	480	670
	96	86	77	67	40
2	115	239	365	495	691
	202	190	179	169	140
3	113	241	371	505	709
	307	296	282	269	240
4	109	241	373	509	722
	411	397	384	371	340
5	103	237	371	509	726
	516	501	486	470	440
7	87	225	361	501	711
	724	709	691	674	641
9	72	208	344	482	672
	933	916	897	877	841
11	54	190	326	462	629
	1142	1117	1096	1075	1045

Flow (GPM)

TORQUE (LB IN) 711
SPEED (RPM) 641

TJ 0045 **2.5 cu in / rev** PRESSURE (PSID)

	500	1000	1500	2000	2750
.5	121	272	425	579	809
	41	35	28	22	10
1	126	282	440	599	832
	86	79	72	65	50
2	128	288	452	619	860
	176	168	161	152	136
3	126	287	453	620	874
	266	257	249	239	221
4	123	285	454	624	876
	356	346	337	326	306
5	119	281	451	624	874
	446	435	425	413	392
7	105	270	440	615	862
	625	613	601	587	562
9	94	259	430	605	865
	805	791	777	761	733
11	79	245	415	590	848
	984	968	951	930	897

Flow (GPM)

TORQUE (LB IN) 862
SPEED (RPM) 562

Cont. Int.

Intermittent operation rating applies to 10% of every minute.
Fonctionnement interm. 10% max. de chaque minute d'utilisation.

Performance data based on testing using 10W40 oil with a viscosity of 200 SUS at 54° C (130° F). Performance data is typical. Actual data may vary slightly from one production motor to another.

Les donnees sur les performances sont basees sur des tests utilisant de l'huile 10W40 d'une viscosite de 200 SUS a 54°C (130°F). Ces donnees correspondent a des situations typiques. Les donnees reelles peuvent varier legerement d'un moteur de production a l'autre.

Intermittierende Werte maximal 10% von jeder Betriebsminute.
Capacidad de funcionamiento intermitente valida para 6 segundos por cada minuto.

Leistungsdaten sind gemessen mit SAE 10W40 bei einer Viskosität von 43,1 Cst bei 54°C. Geringfügige Abweichungen von den Katalogdaten sind möglich.

Datos tecnicos obtenidos con aceite 10W40 de 200 SUS de viscosidad a 54°C (130°F). Los datos proporcionados son valores tipicos. Los valores exactos reales podrian tener una pequena variacion entre distintos motores.

TJ 0050 3.0 cu in / rev PRESSURE (PSID)

	500	1000	1500	2000	2750
.5	146 32	327 23	516 13	705 6	
1	159 69	345 60	537 50	727 41	1005 18
2	170 146	364 136	563 124	764 113	1051 85
3	167 225	363 214	565 203	768 191	1079 161
4	169 294	367 282	574 271	784 260	1089 232
5	165 363	365 349	574 339	785 327	1099 294
7	156 501	357 485	568 474	782 460	1094 429
9	141 640	342 621	555 609	771 594	1084 561
13	86 903	299 879	506 868	724 852	1038 809

Flow (GPM)

TORQUE (LB IN) 1094
SPEED (RPM) 429

TJ 0065 4.0 cu in / rev PRESSURE (PSID)

	500	1000	1500	2000	2750
.5	220 24	481 17	743 11	1004 3	
1	232 52	498 45	763 38	1025 31	1418 20
2	239 109	512 102	789 94	1066 85	1457 67
3	238 167	512 159	790 151	1068 141	1489 122
4	237 224	514 215	795 207	1078 197	1496 180
5	233 279	511 271	794 262	1080 252	1500 235
7	216 386	497 376	783 366	1072 356	1496 337
9	195 494	477 483	764 472	1054 460	1492 440
12	152 654	435 641	724 629	1017 617	1450 596
15	102 802	388 789	680 775	969 763	1394 740

Flow (GPM)

TORQUE (LB IN) 1496
SPEED (RPM) 337

Cont. Int.

Intermittent operation rating applies to 10% of every minute.
Fonctionnement interm. 10% max. de chaque minute d'utilisation.

Performance data based on testing using 10W40 oil with a viscosity of 200 SUS at 54° C (130° F). Performance data is typical. Actual data may vary slightly from one production motor to another.

Les donnees sur les performances sont basees sur des tests utilisant de l'huile 10W40 d'une viscosite de 200 SUS a 54°C (130°F). Ces donnees correspondent a des situations typiques. Les donnees reelles peuvent varier legerement d'un moteur de production a l'autre.

Intermittierende Werte maximal 10% von jeder Betriebsminute.

Capacidad de funcionamiento intermitente valida para 6 segundos por cada minuto.

Leistungsdaten sind gemessen mit SAE 10W40 bei einer Viskosität von 43,1 Cst bei 54°C. Geringfügige Abweichungen von den Katalogdaten sind möglich.

Datos tecnicos obtenidos con aceite 10W40 de 200 SUS de viscosidad a 54°C (130°F). Los datos proporcionados son valores tipicos. Los valores exactos reales podrian tener una pequena variacion entre distintos motores.

TJ 0080 **5.0 cu in / rev** PRESSURE (PSID)

	500	1000	1500	2000	2750
.5	261 17	575 8			
1	276 39	596 30	918 23	1245 13	
2	290 85	631 76	974 68	1310 56	1774 37
3	291 131	633 122	978 113	1319 101	1819 79
4	293 177	642 167	995 158	1347 146	1846 122
5	290 223	641 213	999 203	1359 191	1869 166
7	273 316	628 304	989 293	1353 280	1887 255
9	249 408	603 396	966 384	1334 370	1869 340
12	197 546	551 533	916 519	1287 504	1815 472
15	136 686	494 670	857 655	1226 638	1756 605

TORQUE (LB IN) 1887
SPEED (RPM) 255

Flow (GPM)

TJ 0100 **6.0 cu in / rev** PRESSURE (PSID)

	500	1000	1500	2000	2750
.5	315 14	687 7			
1	332 33	710 26	1083 18	1460 9	
2	348 71	751 64	1152 55	1541 45	2081 27
3	350 109	756 102	1160 92	1556 83	2145 62
4	353 147	768 140	1185 130	1596 120	2193 99
5	349 186	771 178	1197 168	1622 158	2220 138
7	330 263	759 254	1191 244	1624 232	2251 209
9	302 340	731 330	1167 319	1606 307	2251 284
12	243 456	671 444	1111 433	1555 420	2193 394
15	176 572	606 558	1042 546	1484 533	2113 506

TORQUE (LB IN) 2251
SPEED (RPM) 209

Flow (GPM)

Cont. Int.

Intermittent operation rating applies to 10% of every minute.
Fonctionnement interm. 10% max. de chaque minute d'utilisation.

Performance data based on testing using 10W40 oil with a viscosity of 200 SUS at 54° C (130° F). Performance data is typical. Actual data may vary slightly from one production motor to another.

Les donnees sur les performances sont basees sur des tests utilisant de l'huile 10W40 d'une viscosite de 200 SUS a 54°C (130°F). Ces donnees correspondent a des situations typiques. Les donnees reelles peuvent varier legerement d'un moteur de production a l'autre.

Intermittierende Werte maximal 10% von jeder Betriebsminute.

Capacidad de funcionamiento intermitente valida para 6 segundos por cada minuto.

Leistungsdaten sind gemessen mit SAE 10W40 bei einer Viskositat von 43,1 Cst bei 54°C. Geringfuegige Abweichungen von den Katalogdaten sind moeglich.

Datos tecnicos obtenidos con aceite 10W40 de 200 SUS de viscosidad a 54°C (130°F). Los datos proporcionados son valores tipicos. Los valores exactos reales podrian tener una pequena variacion entre distintos motores.

TJ 0130 8.0 cu in / rev PRESSURE (PSID)

	500	1000	1500	2000	2750
.5	445 12	962 10	1488 7	2018 3	
1	464 27	996 24	1525 21	2051 17	2839 4
2	482 55	1032 53	1584 49	2136 44	2917 31
3	483 84	1037 81	1594 77	2150 72	2979 60
4	483 113	1051 110	1619 105	2184 100	3018 87
5	478 142	1050 138	1625 133	2201 128	3041 115
7	450 200	1029 195	1613 190	2195 183	3049 170
9	414 257	993 252	1579 247	2166 239	3033 223
12	338 344	915 338	1503 331	2096 323	2963 306
15	252 431	827 424	1408 416	1996 407	2854 389

TORQUE (LB IN) 3049
SPEED (RPM) 170

Flow (GPM)

TJ 0165 10.0 cu in / rev PRESSURE (PSID)

	500	1000	1500	2000	2750
.5	552 9	1175 7	1813 4	2457 3	
1	574 21	1213 18	1856 16	2499 12	3472 6
2	597 44	1263 41	1938 38	2614 33	3576 25
3	600 67	1273 64	1955 60	2634 55	3654 46
4	603 90	1299 87	1997 83	2691 78	3706 67
5	597 113	1302 109	2015 105	2727 100	3758 89
7	569 159	1286 155	2009 150	2732 144	3784 133
9	523 205	1244 201	1976 195	2707 189	3766 177
12	429 274	1152 269	1890 263	2630 256	3697 242
15	316 344	1039 338	1769 331	2500 323	3576 308

TORQUE (LB IN) 3784
SPEED (RPM) 133

Flow (GPM)

Cont. Int.

Intermittent operation rating applies to 10% of every minute.
Fonctionnement interm. 10% max. de chaque minute d'utilisation.

Performance data based on testing using 10W40 oil with a viscosity of 200 SUS at 54° C (130° F). Performance data is typical. Actual data may vary slightly from one production motor to another.

Les donnees sur les performances sont basees sur des tests utilisant de l'huile 10W40 d'une viscosite de 200 SUS a 54°C (130°F). Ces donnees correspondent a des situations typiques. Les donnees reelles peuvent varier legerement d'un moteur de production a l'autre.

Intermittierende Werte maximal 10% von jeder Betriebsminute.

Capacidad de funcionamiento intermitente valida para 6 segundos por cada minuto.

Leistungsdaten sind gemessen mit SAE 10W40 bei einer Viskositat von 43,1 Cst bei 54°C. Geringfuegige Abweichungen von den Katalogdaten sind moeglich.

Datos tecnicos obtenidos con aceite 10W40 de 200 SUS de viscosidad a 54°C (130°F). Los datos proporcionados son valores tipicos. Los valores exactos reales podrian tener una pequena variacion entre distintos motores.

TJ 0195

11.9 cu in / rev PRESSURE (PSID)

	500	1000	1500	2000	2500
.5	710 8	1519 7	2344 5	3182 3	
1	736 18	1558 16	2387 14	3221 12	4466 6
2	758 37	1596 35	2445 33	3302 30	4528 22
3	758 56	1604 54	2459 51	3315 48	4600 39
4	757 75	1618 73	2482 70	3346 67	4620 56
5	747 95	1615 92	2488 89	3360 85	4630 74
7	705 133	1586 130	2467 127	3343 122	4620 111
9	646 172	1528 169	2415 165	3300 160	4579 147
12	530 230	1408 226	2303 221	3197 215	4497 201
15	394 288	1273 283	2147 278	3027 272	4292 256

TORQUE (LB IN) 4620
SPEED (RPM) 111

Flow (GPM)

TJ 0230

13.9 cu in / rev PRESSURE (PSID)

	500	1000	1500	1750	2000	2400
.5	761 7	1673 6	2614 5	3094 4	3584 3	4347 3
1	791 15	1712 14	2650 13	3128 12	3615 11	4367 9
2	819 32	1764 30	2726 29	3208 28	3692 26	4450 24
3	819 48	1771 47	2737 45	3226 44	3718 42	4502 41
4	821 65	1787 63	2765 61	3256 60	3750 58	4533 56
5	808 81	1786 79	2777 77	3277 76	3778 74	4554 73
7	770 114	1756 112	2755 109	3255 108	3760 106	4554 104
9	705 147	1699 145	2710 142	3216 140	3724 138	4512 137
12	581 197	1582 194	2595 191	3103 189	3617 186	4378 183
15	400 247	1409 243	2437 239	2949 237	3466 235	4232 230
20	64 329	1052 325	2067 321	2580 319	3100 316	3828 311

TORQUE (LB IN) 4554
SPEED (RPM) 104

Flow (GPM)

Cont. Int.

Intermittent operation rating applies to 10% of every minute.
Fonctionnement interm. 10% max. de chaque minute d'utilisation.
Performance data based on testing using 10W40 oil with a viscosity of 200 SUS at 54° C (130° F). Performance data is typical. Actual data may vary slightly from one production motor to another.
Les donnees sur les performances sont basees sur des tests utilisant de l'huile 10W40 d'une viscosite de 200 SUS a 54°C (130°F). Ces donnees correspondent a des situations typiques. Les donnees reelles peuvent varier legerement d'un moteur de production a l'autre.

Intermittierende Werte maximal 10% von jeder Betriebsminute.
Capacidad de funcionamiento intermitente valida para 6 segundos por cada minuto.
Leistungsdaten sind gemessen mit SAE 10W40 bei einer Viskositat von 43,1 Cst bei 54°C. Geringfuegige Abweichungen von den Katalogdaten sind moeglich.
Datos tecnicos obtenidos con aceite 10W40 de 200 SUS de viscosidad a 54°C (130°F). Los datos proporcionados son valores tipicos. Los valores exactos reales podrian tener una pequena variacion entre distintos motores.

TJ 0260 **15.9** cu in / rev PRESSURE (PSID)

	500	1000	1500	1650	2250
.5	908 7	1961 6	3048 6	3380 6	4643 5
1	938 14	2006 13	3099 13	3433 12	4674 11
2	971 28	2059 27	3165 26	3501 26	4758 23
3	968 43	2065 42	3177 40	3514 39	4800 38
4	970 57	2081 56	3203 54	3541 53	4742 50
5	957 71	2084 70	3219 68	3561 67	4874 64
7	907 100	2049 98	3198 96	3542 95	4842 91
9	837 129	1985 127	3143 124	3489 123	4790 117
12	692 172	1844 169	3016 166	3367 164	4685 157
15	489 215	1647 212	2830 208	3188 206	4485 200
20	129 287	1255 283	2418 279	2773 277	4034 270

TORQUE (LB IN) 4842
SPEED (RPM) 91

Flow (GPM)

TJ 0295 **17.9** cu in / rev PRESSURE (PSID)

	500	1000	1500	1550	2100
.5	1014 6	2216 5	3453 4	3576 4	4907 3
1	1051 12	2270 11	3509 10	3633 10	4943 8
2	1088 25	2334 24	3600 22	3727 22	5073 21
3	1085 38	2338 36	3611 35	3739 34	5133 33
4	1085 50	2353 49	3639 47	3769 47	5156 44
5	1072 63	2352 62	3654 60	3784 59	5180 57
7	1019 89	2311 87	3624 85	3755 84	5157 80
9	939 115	2237 113	3561 110	3693 110	5085 104
12	776 153	2074 151	3403 148	3537 147	4931 142
15	545 192	1853 189	3184 186	3319 185	4694 180
20	126 256	1408 253	2697 249	2826 249	4089 243

TORQUE (LB IN) 5157
SPEED (RPM) 80

Flow (GPM)

Cont. Int.

Intermittent operation rating applies to 10% of every minute.
Fonctionnement interm. 10% max. de chaque minute d'utilisation.
Performance data based on testing using 10W40 oil with a viscosity of 200 SUS at 54° C (130° F). Performance data is typical. Actual data may vary slightly from one production motor to another.
Les donnees sur les performances sont basees sur des tests utilisant de l'huile 10W40 d'une viscosite de 200 SUS a 54°C (130°F). Ces donnees correspondent a des situations typiques. Les donnees reelles peuvent varier legerement d'un moteur de production a l'autre.

Intermittierende Werte maximal 10% von jeder Betriebsminute.
Capacidad de funcionamiento intermitente valida para 6 segundos por cada minuto.
Leistungsdaten sind gemessen mit SAE 10W40 bei einer Viskositat von 43,1 Cst bei 54°C. Geringfuegige Abweichungen von den Katalogdaten sind moeglich.
Datos tecnicos obtenidos con aceite 10W40 de 200 SUS de viscosidad a 54°C (130°F). Los datos proporcionados son valores tipicos. Los valores exactos reales podrian tener una pequena variacion entre distintos motores.

TJ 0330 20.0 cu in / rev PRESSURE (PSID)

	500	1000	1500	1950
.5	1184 5	2507 5	3722 4	5051 2.8
1	1218 11	2558 10	3772 9	5110 7.9
2	1258 22	2632 21	3867 20	5204 18.6
3	1251 34	2633 32	3879 31	5275 29.9
4	1249 45	2649 44	3909 42	5311 39.9
5	1229 57	2648 55	3926 53	5323 50
7	1162 80	2600 78	3898 75	5311 71
9	1064 103	2518 100	3829 98	5228 93
12	875 137	2333 135	3657 131	5027 127
15	621 171	2081 169	3420 165	4779 160
20	163 229	1576 226	2875 222	4140 214

TORQUE (LB IN) 5311
SPEED (RPM) 71

TJ 0365 22.6 cu in / rev PRESSURE (PSID)

	500	1000	1325	1825
.5	1393 5	2942 4	3974 4	5557 3
1	1444 10	3005 9	4036 8	5595 7
2	1494 20	3090 19	4131 18	5671 17
3	1485 30	3082 29	4125 28	5722 27
4	1477 40	3089 39	4139 37	5734 36
5	1452 50	3075 49	4130 47	5734 45
7	1371 70	3009 69	4071 67	5671 63
9	1260 90	2899 89	3669 87	5532 84
12	1002 121	2658 119	3737 117	5266 113
15	700 151	2355 149	3432 146	4937 142
20	152 201	1776 199	2838 196	4228 191

TORQUE (LB IN) 5671
SPEED (RPM) 63

Flow (GPM)

Cont. Int.

Intermittent operation rating applies to 10% of every minute.
Fonctionnement interm. 10% max. de chaque minute d'utilisation.
Performance data based on testing using 10W40 oil with a viscosity of 200 SUS at 54° C (130° F). Performance data is typical. Actual data may vary slightly from one production motor to another.
Les donnees sur les performances sont basees sur des tests utilisant de l'huile 10W40 d'une viscosite de 200 SUS a 54°C (130°F). Ces donnees correspondent a des situations typiques. Les donnees reelles peuvent varier legerement d'un moteur de production a l'autre.

Intermittierende Werte maximal 10% von jeder Betriebsminute.
Capacidad de funcionamiento intermitente valida para 6 segundos por cada minuto.
Leistungsdaten sind gemessen mit SAE 10W40 bei einer Viskositat von 43,1 Cst bei 54°C. Geringfuegige Abweichungen von den Katalogdaten sind moeglich.
Datos tecnicos obtenidos con aceite 10W40 de 200 SUS de viscosidad a 54°C (130°F). Los datos proporcionados son valores tipicos. Los valores exactos reales podrian tener una pequena variacion entre distintos motores.

TJ 0390 **24.0** cu in / rev PRESSURE (PSID)

	500	1000	1250	1750
.5	1326 4	2889 3	3682 2	5235 2
1	1380 9	2934 7	3724 7	5296 6
2	1443 18	3034 17	3840 15	5383 13
3	1442 28	3049 26	3861 25	5457 22
4	1454 37	3084 36	3905 34	5531 32
5	1447 47	3104 45	3935 44	5543 40
7	1393 66	3080 64	3923 62	5568 60
9	1297 85	3013 83	3868 81	5494 79
12	1088 114	2818 112	3686 110	5296 106
15	797 143	2539 140	3414 138	5000 135
20	264 191	2006 188	2880 186	4358 182

TORQUE (LB IN) 5568
SPEED (RPM) 60

Flow (GPM)

Cont. Int.

Intermittent operation rating applies to 10% of every minute.
Fonctionnement interm. 10% max. de chaque minute d'utilisation.
Performance data based on testing using 10W40 oil with a viscosity of 200 SUS at 54° C (130° F). Performance data is typical. Actual data may vary slightly from one production motor to another.
Les donnees sur les performances sont basees sur des tests utilisant de l'huile 10W40 d'une viscosite de 200 SUS a 54°C (130°F). Ces donnees correspondent a des situations typiques. Les donnees reelles peuvent varier legerement d'un moteur de production a l'autre.

Intermittierende Werte maximal 10% von jeder Betriebsminute.
Capacidad de funcionamiento intermitente valida para 6 segundos por cada minuto.
Leistungsdaten sind gemessen mit SAE 10W40 bei einer Viskosität von 43,1 Cst bei 54°C. Geringfügige Abweichungen von den Katalogdaten sind möglich.
Datos tecnicos obtenidos con aceite 10W40 de 200 SUS de viscosidad a 54°C (130°F). Los datos proporcionados son valores tipicos. Los valores exactos reales podrian tener una pequena variacion entre distintos motores.

Wheel Mount / Radnabengehaeuse
Monture à roue / Montaje de rueda

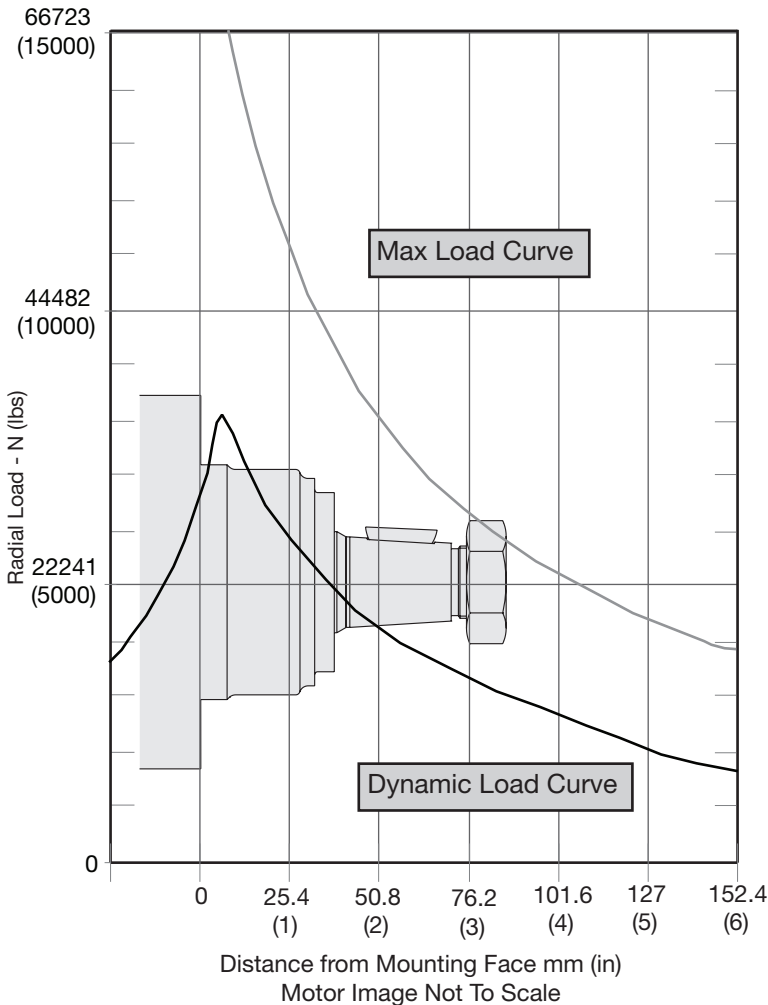

The maximum load curve is defined by bearing static load capacity. This curve should not be exceeded at any time including shock loads.

Die maximale radiale Wellenbelastungskurve ist definiert als maximale statische Last ohne Drehzahl. Sie gilt als Grenze und sollte keinesfalls überschritten werden.

La courbe de charge maximale est définie par la capacité de charge statique portante. Cette courbe ne devrait être dépassée en aucun moment y compris pour les charges par à-coups.

La curva de carga máxima queda definida por la capacidad de carga estática del cojinete. No se deben superar los valores de esta curva, ni siquiera con cargas provisionarias de impacto.

The dynamic side load curve is based on unidirectional steady state loads for L_{10} bearing life at 3×10^6 revolutions.

Die zulässige auslegbare radiale Wellenbelastungskurve ist unter ruhenden, einseitig statisch gerichteten Lastverhältnissen auf eine L_{10} Lebensdauer mit 3×10^6 Umdrehungen kalkuliert.

La courbe de charge latérale permise se base sur des charges unidirectionnelles en régime permanent pour le roulement L_{10} à 3×10^6 révolutions.

La curva de valores admisibles de carga lateral está basada en cargas constantes para cojinetes L_{10} a 3×10^6 revoluciones.

Equation to Calculate the Expected Radial Bearing Life
Gleichung zur Ermittlung der Lagerlebensdauer

Equation to calculate the dynamic bearing life for a given load:
Bestimmung der erlaubten radialen Wellenbelastung mit vorgegebener Last

Use F_a , F_b and S in equation to determine hours of L_{10} bearing life.
Die Lebensdauer in Stunden ergibt sich durch einsetzen von F_a , F_b , und S in die nachstehende Formel.

$$L = \frac{3 \times 10^6}{60 \times S} \left\{ \frac{F_a}{F_b} \right\}^{3.33}$$

Where / Mit:

S = Shaft Speed RPM / Abtriebswellendrehzahl in min^{-1}

L = Life In Hours / Lebensdauer in Stunden

F_a = Dynamic side load defined by above curve at a distance from mounting flange. / Erlaubte radiale Wellenbelastung als Function der Laenge

F_b = Application side load. / Anwendungsseitige Wellenbelastung

Note: Calculations are based on L_{10} bearing life per ISO 281.
Auslegung basiert auf einer L_{10} Lebensdauer nach ISO 281

Code: US

Wheel Mount, 7/8-14 SAE O-Ring

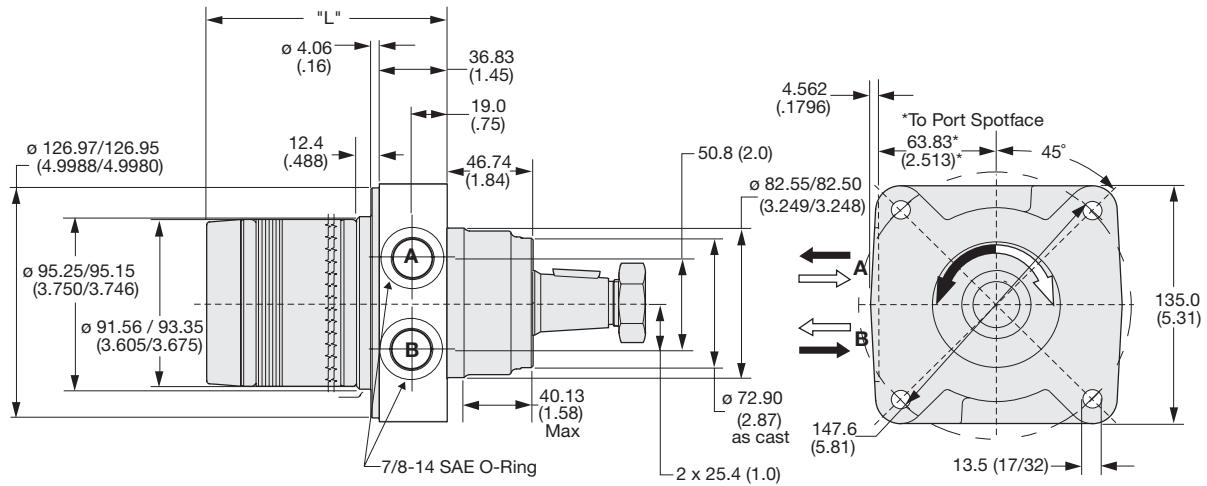

Code US	disp.	0036	0045	0050	0065	0080	0100	0130	0165	0195	0230	0260	0295	0330	0365	0390
Weight/Gewicht	kg	6.67	6.80	6.90	7.00	7.10	7.20	7.60	7.80	8.10	8.30	8.60	8.80	9.10	9.40	9.60
Poids/Peso	(lb)	(14.7)	(15.0)	(15.2)	(15.4)	(15.6)	(15.8)	(16.7)	(17.2)	(17.9)	(18.3)	(19.0)	(19.4)	(20.0)	(20.7)	(21.2)
Length	"L" mm	105.8	106.9	108.4	111.5	114.7	117.8	124.3	130.6	137.0	143.3	149.7	156.0	162.4	171.0	175.1
	"L" (in)	(4.17)	(4.21)	(4.27)	(4.39)	(4.52)	(4.64)	(4.89)	(5.14)	(5.39)	(5.64)	(5.89)	(6.14)	(6.39)	(6.73)	(6.89)

English equivalents for metric specifications are shown in ().

005 TJ.indd, js

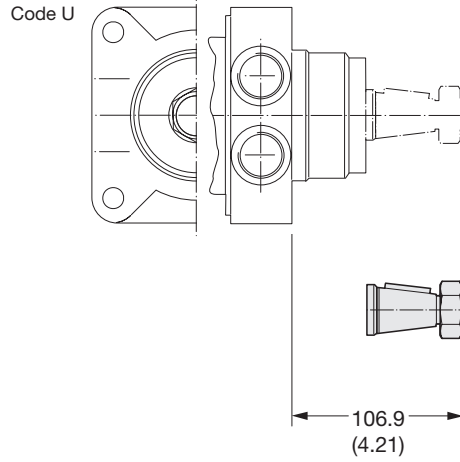

Code: 08

1 1/4" Tapered

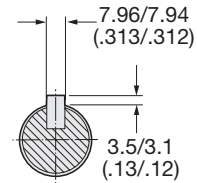
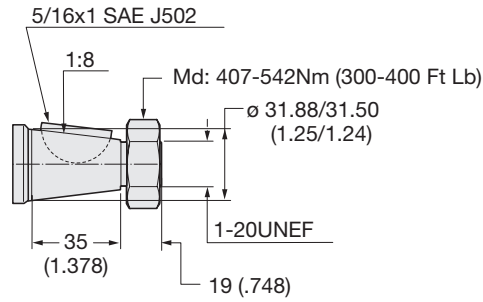

English equivalents for metric specifications are shown in ().

005 TJ.indd, js