

Spirit^{IT} Flow-X

High accuracy flow computers



Operation and configuration –
Liquid Metric

Measurement made easy

—
Flow-X/P with
Flow-X/M module

Introduction

Welcome to the exciting world of Spirit^{IT} Flow-X!

This manual is the operation and configuration manual for the Spirit^{IT} Flow-X Liquid Metric application.

There are three reference manuals:

- Volume I – This Installation manual, with the installation instructions.
- Volume II – The Operation and Configuration manual. This manual consists of a general part and one of the following application-specific parts:
 - IIA - Operation and configuration
 - IIB - Gas Metric application
 - IIC - Liquid Metric application
 - IID - Gas US customary units application
 - IIE - Liquid US customary units application
- Volume III - The manuals for solutions that exceed our standard applications. This volume consists of 1 part:
 - IIIB - Function referencere

For more information

All publications of Spirit^{IT} Flow-X are available for free download from:



	Search for:
Spirit ^{IT} Flow-X instruction manual	IM/FlowX-EN
Spirit ^{IT} Flow-X configuration manual	CM/FlowX-EN
Spirit ^{IT} Flow-X gas metric application manual	CM/FlowX/GM-EN
Spirit ^{IT} Flow-X liquid metric application manual	CM/FlowX/LM-EN
Spirit ^{IT} Flow-X gas USC application manual	CM/FlowX/GU-EN
Spirit ^{IT} Flow-X liquid USC application manual	CM/FlowX/LU-EN
Spirit ^{IT} Flow-X function reference manual	CM/FlowX/RF-EN

Table of contents

1	Manual introduction	5		
	Purpose of this manual.....	5		
	Overview	5		
	Document conventions	5		
	Abbreviations	6		
	Terms and definitions.....	7		
2	Application overview.....	8		
	Capabilities	8		
	Typical meter run configurations.....	8		
	Application versions.....	9		
	Input signals.....	10		
	Flow meter input.....	10		
	Process inputs	10		
	Digital status and command inputs	11		
	Densitometers.....	11		
	Output signals.....	11		
	Analog outputs.....	11		
	Pulse outputs.....	11		
	Digital status and command outputs.....	11		
	Pulse outputs.....	12		
	Batch operation	12		
	Proving functionality.....	12		
	Control features.....	12		
	Sample control	12		
	Valve control	12		
	Flow / pressure control.....	12		
	Loading control.....	13		
	Loading data entry	13		
	Loading permissives	13		
	Batch control.....	13		
	Block valve control.....	13		
	Flow control	13		
	Pump control	14		
	Sampler control.....	14		
	Shakeout registration and batch recalculation	14		
	BS&W lockout.....	14		
3	Operation.....	15		
	In-use values.....	15		
	Flow rates	15		
	Product.....	16		
	Temperature	16		
	Pressure	16		
	Density	18		
	Observed density, standard density	18		
	Meter density.....	18		
	Densitometers.....	18		
	Densitometer selection	19		
	BS&W.....	19		
	Viscosity.....	19		
	Batching.....	20		
	Batch control.....	20		
	Defining the batch stack.....	20		
	Scheduled batch ends.....	20		
	Batch recalculation	21		
	Proving.....	22		
	Proving operation	22		
	Prove required flags	22		
	Valve control.....	24		
	Flow / pressure control	25		
	Sampler control.....	26		
	Sample settings.....	26		
	Loading control	28		
	Loading state	28		
	Loading control	28		
	Loading data	29		
	Loading permissives	29		
	Truck driver display.....	29		
	Transloader displays	29		
4	Configuration	30		
	Introduction	30		
	I/O setup.....	31		
	Analog inputs	31		
	PT100 inputs.....	31		
	Digital IO assign	31		
	Digital IO settings	32		
	Pulse inputs	32		
	Time period inputs.....	34		
	Analog outputs	34		
	Pulse outputs	34		
	Frequency outputs.....	35		
	Forcing I/O	35		
	Overall setup	36		
	Flow computer concepts.....	36		
	Common settings	37		
	Meter ticket	39		
	Period settings	40		
	Display levels.....	41		
	Customer definition	42		
	SNTP time Synchronization	42		
	System data.....	42		
	Product definition.....	43		
	Meter run setup	46		
	Run setup	46		
	Run control setup.....	46		
	Flow meter setup	47		
	Pulse input	47		
	Smart meter	47		
	Meter K-factor.....	48		
	Meter factor / error	49		
	Data valid input.....	50		
	Flow direction	51		
	Viscosity correction.....	52		
	Indicated totalizers.....	52		
	Serial mode.....	52		
	Orifice	53		
	Venturi	54		
	V-cone	55		
	Venturi nozzle, long radius nozzle and ISA1932 nozzle	56		

dP inputs.....	57	Hydrometer Correction.....	111
dP input A, B and C	58	API-2540 Input Data Limits	111
Station setup	59	API-2540 Rounding and truncating rules	113
Station setup	59	API-11.1:2004/2007 Input Data Limits	113
Station control setup	59	API constants	113
Meter runs	59	Volume Correction factor C_{TL}	114
Temperature setup.....	61	Volume Correction factor C_{PL}	114
Temperature transmitters.....	61	Density calculations.....	114
Temperature transmitter selection	62	Densitometer calculations	115
Pressure setup.....	63	Solartron densitometers	115
Pressure transmitters.....	63	Sarasota densitometers	115
Pressure transmitter selection	64	UGC densitometers	115
Density setup.....	65	Anton Paar densitometers	115
Observed density	66	Meter body correction	116
Densitometer setup	67	Viscosity correction	116
Standard density.....	69	Correction for Sediment and Water (BS&W).....	116
BS&W setup.....	70	Flow rates for volumetric flow meters	116
Viscosity setup	71	Indicated flow rate.....	116
Batching	73	Gross volume flow rate	117
Product selection.....	74	Mass flow rate.....	117
Analog outputs.....	75	Flow rates for mass flow meters	117
Pulse outputs.....	76	Indicated flow rate.....	117
Frequency outputs	77	Mass flow rate.....	117
Snapshot report.....	78	Gross volume flow rate	117
Valve control	79	Standard volume flow rate.....	118
Flow / pressure control.....	81	Gross standard volume flow rate	118
Sampler control.....	84	Net standard volume flow rate	118
Sampler settings.....	84	Flow rate for differential pressure flow devices	118
Can settings	86	Mass flowrate (ISO-5167)	118
Customer cans.....	87	Device and pipe diameter (Corrected) at operating	
Proving	88	temperature	118
Proving setup.....	88	Diameter (Beta) Ratio	118
Proving using a ball or compact prover	88	Reynolds Number	118
Master meter proving	93	Velocity of Approach (E_v).....	118
Operational settings	96	Fluid Expansion Factor ϵ	118
Stability check	97	Down- to upstream corrections	119
Meter factor tests.....	98	Pressure correction	119
Prove report	98	Temperature correction	119
Meter runs	99	Orifice correction for drain hole	119
Loading	100	Differential pressure cell selection.....	119
Loading setup.....	100	Proving Calculations.....	120
Loading operational settings	101	Proving of volumetric meters with pipe / compact	
Loading data entry	102	/ small volume prover	120
Loading permissives	103	Inferred mass proving.....	121
Booster pump.....	103	Master meter proving	121
Product evaluation	104	Ethylene.....	122
Divert valve control.....	104	Propylene and water / stream	122
Digital flow control valve.....	104		
Two-stage control valve	105		
Metrological settings.....	107		
5 Maintenance mode	108	7 Reports	124
6 Calculations	109	Standard reports.....	124
API Petroleum Measurement Tables	109	8 Communication	126
NGL and LPG tables.....	109	Standard Modbus communication lists.....	126
Overview of hydrocarbon liquid conversion		Modbus Tag List.....	126
standards.....	110	Modbus Tag List 16 bits.....	126
Overview of the functions.....	111	Connect to remote station	126
		Connect to remote run.....	126
		Connect to remote prover IO server	126
		Act as remote prover IO server	126

- Omni compatible communication list126
- Modbus devices127
- HART devices127
- 9 Historical Data Archives128**
 - Standard Data Archives.....128
- 10 MID Compliance129**
 - Accountable alarms.....129
 - Neutralization129
- 11 Revisions130**
 - Revision A.....130
 - Revision B.....130
 - Revision C130
 - Revision D130
 - Revision E.....130
 - Revision F.....130
 - Revision G130

1 Manual introduction

Purpose of this manual

This Flow-X reference manual is written for a variety of readers:

- The **application developer**, who is interested in all details required to develop a complete flow measurement solution with a Flow-X product.
- The **Instrumentation engineer**, who selects the appropriate flow computer model, assigns inputs and outputs and designs transmitter loops and flow computer functionality
- A more generally **interested reader**, who investigates whether the capabilities and features of Flow-X will satisfy his/her project requirements.

This manual expects the reader to be commonly acquainted with flow measurement principles, such as turbine, orifice and ultrasonic measurements. This manual is not an introduction to these techniques.

Overview

This manual works in conjunction with manual IIA 'Operation and Configuration' that covers the **common** operation and configuration aspects of the Flow-X flow computer.

The Flow-X flow computer family comes with the following 4 standard software applications:

- Gas Metric
- Liquid Metric
- Gas US Customary (USC)
- Liquid US Customary (USC)

Each application can be used for a single meter run or for a meter station consisting of multiple meter runs.

This application manual describes the specific functions and capabilities of the **Liquid Metric** Application.

Document conventions



When the book symbol as displayed at the left appears in the text in this manual, a reference is made to another section of the manual. At the referred section, more detailed, or other relevant information is given.



When in this manual a symbol as displayed at the left appears in the text, certain specific operating instructions are given to the user. In such as case, the user is assumed to perform some action, such as the selection of a certain object, worksheet, or typing on the keyboard.



A symbol as displayed at the left indicates that the user may read further on the subject in one of the sample workbooks as installed on your machine.



When an important remark is made in the manual requiring special attention, the symbol as displayed to the left appears in the text

Abbreviations

Throughout this document the following abbreviations are used:

ADC	Analog to Digital converter
AI	Analog Input
AO	Analog Output
API	Application Programming Interface An interface that allows an application to interact with another application or operating system, in our case, Flow-X. Most of the Flow-X API is implemented through Excel worksheet functions.
ASCII	American Standard Code for Information Interchange. A set of standard numerical values for printable, control, and special characters used by PCs and most other computers. Other commonly used codes for character sets are ANSI (used by Windows 3.1+), Unicode (used by Windows 95 and Windows NT), and EBCDIC (Extended Binary-Coded Decimal Interchange Code, used by IBM for mainframe computers).
BS&W	Basic (or Bottom) Sediment and Water BS&W includes free water, sediment (sand, mud) and emulsion and is measured as a volume percentage is measured from a liquid sample of the production stream.
CPU	Central Processing Unit
DAC	Digital to Analog Converter
DCS	Distributed Control System
DDE	Dynamic Data Exchange A relatively old mechanism for exchanging simple data among processes in MS-Windows.
DI	Digital Input
DO	Digital Output
EGU	Engineering Units
EIA	Electrical Industries Association
FET	Field Effect Transistor
GUI	Graphical User Interface
HART	Highway Addressable Remote Transducer. A protocol defined by the HART Communication Foundation to exchange information between process control devices such as transmitters and computers using a two-wire 4-20mA signal on which a digital signal is superimposed using Frequency Shift Keying at 1200 bps.
HMI	Human Machine Interface. Also referred to as a GUI or MMI. This is a process that displays graphics and allows people to interface with the control system in graphic form. It may contain trends, alarm summaries, pictures, and animations.
I/O	Input/Output
IEEE	Institute for Electrical and Electronics Engineers
ISO	International Standards Organization
MMI	Man Machine Interface (see HMI)
MIC	Machine Identification Code. License code of Flow-X which uniquely identifies you computer.
OEM	Original Equipment Manufacturer
P&ID	Piping and Instrumentation Diagram
PC	Personal Computer
PCB	Printed Circuit Board
PLC	Programmable Logic Controller. A specialized device used to provide high-speed, low-level control of a process. It is programmed using Ladder Logic, or some form of structured language, so that engineers can program it. PLC hardware may have good redundancy and fail-over capabilities.
RS232	EIA standard for point to point serial communications in computer equipment
RS422	EIA standard for two- and four-wire differential unidirectional multi-drop serial
RS485	EIA standard for two-wire differential bidirectional multi-drop serial communications in computer equipment
RTU	Remote Terminal Unit
SCADA	Supervisory Control and Data Acquisition
SQL	Standard Query Language
SVC	Supervisory Computer
TCP/IP	Transmission Control Protocol/Internet Protocol. Transmission Control Protocol/Internet Protocol. The control mechanism used by programs that want to speak over the Internet. It was established in 1968 to help remote tasks communicate over the original ARPANET.
TTL	Transistor-Transistor Logic
UART	Universal Asynchronous Receiver & Transmitter
URL	Uniform Resource Locator. The global address for documents and resources on the World Wide Web.
XML	Extensible Markup Language. A specification for Web documents that allows developers to create custom tags that enable the definition, transmission, validation and interpretation of data contained therein.

Terms and definitions

Throughout this manual the following additional terms and definitions are used:

API Gravity	Measure for the density of a petroleum liquid. The heavier the liquid the lower the API gravity. The API scale was designed so that most values would fall between 10 and 70 API gravity degrees
Asynchronous	A type of message passing where the sending task does not wait for a reply before continuing processing. If the receiving task cannot take the message immediately, the message often waits on a queue until it can be received.
Client/server	A network architecture in which each computer or process on the network is either a client or a server. Clients rely on servers for resources, such as files, devices, and even processing power. Another type of network architecture is known as a peer-to-peer architecture. Both client/server and peer-to-peer architectures are widely used, and each has unique advantages and disadvantages. Client/server architectures are sometimes called two-tier architectures
Device driver	A program that sends and receives data to and from the outside world. Typically a device driver will communicate with a hardware interface card that receives field device messages and maps their content into a region of memory on the card. The device driver then reads this memory and delivers the contents to the spreadsheet.
Engineering units	Engineering units as used throughout this manual refers in general to the units of a tag, for example 'bar', or '°C', and not to a type of unit, as with 'metric' units, or 'imperial' units.
Ethernet	A LAN protocol developed by Xerox in cooperation with DEC and Intel in 1976. Standard Ethernet supports data transfer rates of 10 Mbps. The Ethernet specification served as the basis for the IEEE 802.3 standard, which specifies physical and lower software layers. A newer version, called 100-Base-T or Fast Ethernet supports data transfer rates of 100 Mbps, while the newest version, Gigabit Ethernet supports rates of 1 gigabit (1000 megabits) per second.
Event	Anything that happens that is significant to a program, such as a mouse click, a change in a data point value, or a command from a user.
Exception	Any condition, such as a hardware interrupt or software error-handler, that changes a program's flow of control.
Fieldbus	A set of communication protocols that various hardware manufacturers use to make their field devices talk to other field devices. Fieldbus protocols are often supported by manufacturers of sensor hardware. There are debates as to which of the different fieldbus protocols is the best. Popular types of fieldbus protocol include Modbus, Hart, Profibus, Devicenet, InterBus, and CANopen.
Factored density	The density as measured by a densitometer corrected for DCF (Density Correction Factor). DCF is determined from a calibration. It is also called 'Observed density', 'Measured density' or 'Flowing density'.
Flowing density	The density at the flowing conditions of pressure and temperature This is typically the density as measured by a densitometer. It is also called 'Observed density', 'Measured density' or 'Factored density'. The 'Measured density' is the density of the fluid at the temperature and pressure at the density measurement point, which is therefore not necessarily the same as the density value at the flow meter.
Gross volume	The corrected actual volume; as indicated by the flow meter and corrected for the flow meter calibration curve (if applicable), the meter factor, the meter body expansion and the viscosity influence (for helical turbine and PD meters).
Indicated volume	The uncorrected actual volume; as indicated by the flow meter without any correction being applied.
Kernel	The core of Flow-X that handles basic functions, such as hardware and/or software interfaces, or resource allocation.
Measured density	The density as measured a densitometer. It is also called 'Observed density', 'Flowing density' or 'Factored density'. The 'Measured density' is the density of the fluid at the temperature and pressure at the density measurement point, which is therefore not necessarily the same as the density value at the flow meter.
Meter density	The density at of the fluid at the flow meter conditions of temperature and pressure. The meter density is calculated from the standard density and the the Ctl and Cpl factors.
Observed density	The density as observed (measured) by the densitometer. It is also called 'Flowing density', 'Measured density' or 'Factored density' The 'Observed density' is the density of the fluid at the temperature and pressure at the density measurement point, which is therefore not necessarily the same as the density value at the flow meter.
Peer-to-peer	A type of network in which each workstation has equivalent capabilities and responsibilities. This differs from client/server architectures, in which some computers are dedicated to serving the others. Peer-to-peer networks are generally simpler, but they usually do not offer the same performance under heavy loads. Peer-to-peer is sometimes shortened to the term P2P.
Polling	A method of updating data in a system, where one task sends a message to a second task on a regular basis, to check if a data point has changed. If so, the change in data is sent to the first task. This method is most effective when there are few data points in the system. Otherwise, exception handling is generally faster.

2 Application overview

This chapter lists the features of the Liquid Metric application and shows some typical meter run configurations that are covered by it.

Capabilities

The Liquid Metric application has the following capabilities:

- Supports both single meter runs and meter stations consisting of several meter runs.
- Support of turbine, PD, ultrasonic, Coriolis, orifice, venturi, V-cone and nozzle flow meters
- Supports any type of flow meters outputting a flow rate through an analog, HART or Modbus signal
- Analog, HART and Modbus options for live inputs
- Last good, keypad and fallback options for failing input signals
- Automatic switching from HART to analog signal in case of HART failure
- Automatic use of backup signal for smart meters with an additional pulse output
- Data valid input (in combination with a pulse input)
- One, two and three dP cells
- One or two densitometers both on stream and station level (time period inputs)
- One or two prover densitometers (time period inputs)
- Support for Anton Paar densitometers (HART or Modbus)
- Meter body correction for pressure and temperature
- Viscosity calculation according to ASTM D341-09
- Viscosity correction
- Process inputs for density, standard density, viscosity and BS&W
- Selectable meter factor / meter K-factor interpolation curves (12 points)
- Batch totals and averages
- Hourly and daily totals and averages
- Additional 2 freely definable periods for totals and averages
- Batch stack of 6 batches
- 16 configurable products
- Auto batch end (daily, scheduled, batch size or no flow)
- Auto product selection on density interface, digital inputs, modbus or valve position
- Several standards for standard density calculation:
 - API 53/54 A/B/C/D (1952/1980/2007)
 - API 59/60 A/B/C/D (1952/1980/2007)
 - API 5/6 A/B/D (1952/1980/2007)
 - API 23/24 A/B/D (1952/1980/2007)
 - NLG/LPG tables API 23/24 E, 53/54 E, 59/60 E (2007)
 - Water / Steam (IAPWS-IF97)
 - Ethylene (IUPAC, NIST1045, API 11.3.2.1)
 - Propylene (API 11.3.3.2)
 - Butadiene (ASTM_D1550)
 - Asphalt (ASTM D4311/4311M)
- Built-in support for Caldon and Faure Herman ultrasonic flow meters
- Built-in support for ABB, Micro Motion and Endress+Hauser coriolis flow meters
- User-definable HART and Modbus interface to any other type of flow meter
- Orifice, venturi, V-cone, venturi nozzle, long radius nozzle and ISA1932 nozzle standards: ISO-5167, AGA-3
- Cross-module I/O sharing
- Indication of total rollover on reports
- Indication of input override / failure on reports
- Diagnostic displays for smart meters
- Station functionality
- Batch recalculation
- Forward and reverse totalizers and averages
- Maintenance totalizers
- Accountable / non-accountable totalizers
- Valve control
- Flow control / pressure (PID) control
- Sampler control
- Remote station flow computer functionality
- Remote prover flow computer functionality
- Prover remote IO functionality
- Proving with bi- or uni-directional ball prover, Brooks compact prover or Calibron / Flow MD small volume prover
- Master meter proving
- Batch reports
- Daily, hourly, period A and period B reports
- Daily events and alarm reports
- Snapshot reports
- Proving reports
- Batch historical data archive
- Daily historical data archive
- Complete Modbus tag list (32 bits registers)
- Abbreviated Modbus tag list (16 bits registers)
- Omni compatible tag lists (v24, v24 bi-dir., v25)
- Optional loading functionality

Typical meter run configurations

The application has been designed for liquid flow metering stations consisting of one or more parallel meter runs with all values and flow computations in metric units.

The application supports batch type of operation as well as continuous operation with hourly and daily custody transfer data.

For meter stations the meter runs may run independently or with a common density input and/or product definition.

The following typical meter stations are supported:

- Single meter run
- Meter station with independent meter runs that run different products with one or two densitometers installed on each run.

- Meter station with multiple meter runs that run one common product with one or two common densitometers on the header.
- Meter station with an additional run for master meter proving (optional cross-over valves).

A **single Flow-X/M module** in a Flow-X/S, Flow-X/K or Flow-X/R enclosure is typically used for a single meter run. A single module can also be used to control a meter station and/or proving, whereby it communicates to a number of remote Flow-X/M modules that control the meter run(s). In this case each Flow-X/M is running its own single stream application. For station/proving functionality, a separate Flow-X/M can be used, which communicates to up to 8 remote run Flow-X/M modules. Alternatively, station and/or master meter proving functionality can be enabled on the first run module. This will then be a combined station / proving / run module with one local run (run 1) and up to 7 remote runs (runs 2 to 8).

A **Flow-X/P** can control metering stations of maximum 4 meter runs. For each meter run the Flow-X/P must be equipped with a Flow-X/M module. All station and proving functionality is executed by the Flow-X/P panel and the meter run functionality is executed by the individual Flow-X/M modules. In this case the application has to be configured as a single application, which is sent to the Flow-X/P as a whole.

A **Flow-X/C** can control metering stations of maximum 2 meter runs. All meter run functionality, station functionality and proving functionality is executed by the Flow-X/C, which is running a dedicated multi-stream application.

Example

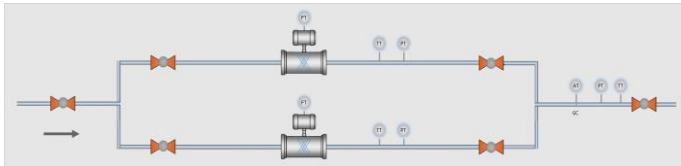

Figure 1: Metering station with 2 meter runs and common on-line analyzers (densitometer, viscosity, BS&W meter) on the header

For this metering station the following flow computer configurations can be used:

- One Flow-X/P with 2 Flow-X/M modules, one for each meter run. Each module handles 1 meter run and the panel handles station functionality (station totals and common analyzers).
- 3 Flow-X/M modules in Flow-X/S, Flow-X/K or Flow-X/R enclosures:
 - 2 Flow-X/M modules for the meter runs
 - 1 Flow-X/M module for the station functionality
 The station module communicates to the run modules to read the totalizer data and to send the common analyzer values.
- 2 Flow-X/M modules in Flow-X/S, Flow-X/K or Flow-X/R enclosures:
 - 1 Flow-X/M module that controls the station and meter run 1

- 1 Flow-X/M that controls meter run 2

The combined station/run module communicates to the other run module to read the totalizer data and to send the common analyzer values.

- Flow-X/C with multi-stream application, which handles station functionality and both runs.

In each of the above configurations, the station may also include proving logic (not shown in the picture).

Application versions

The application comes in 3 separate versions:

- **Full application**, to be used for single stream, remote station / remote run and remote prover IO configurations on version 1 hardware (X/M, X/P1) and version 2 hardware (X/M, X/C, X/P1).
- **Abridged application**, to be used for multiple stream X/P applications (X/P2, X/P3, X/P4) on version 1 hardware. In order to fit into the version 1 hardware's limited memory, the following restrictions apply:
 - Single flow direction (no reverse totals and averages)
 - Only 2 sets of period totals and averages (daily and a configurable period A)
- **V2 2 runs application** for multiple stream applications on version 2 hardware, running up to 2 runs within one X/C, X/M or X/P1.

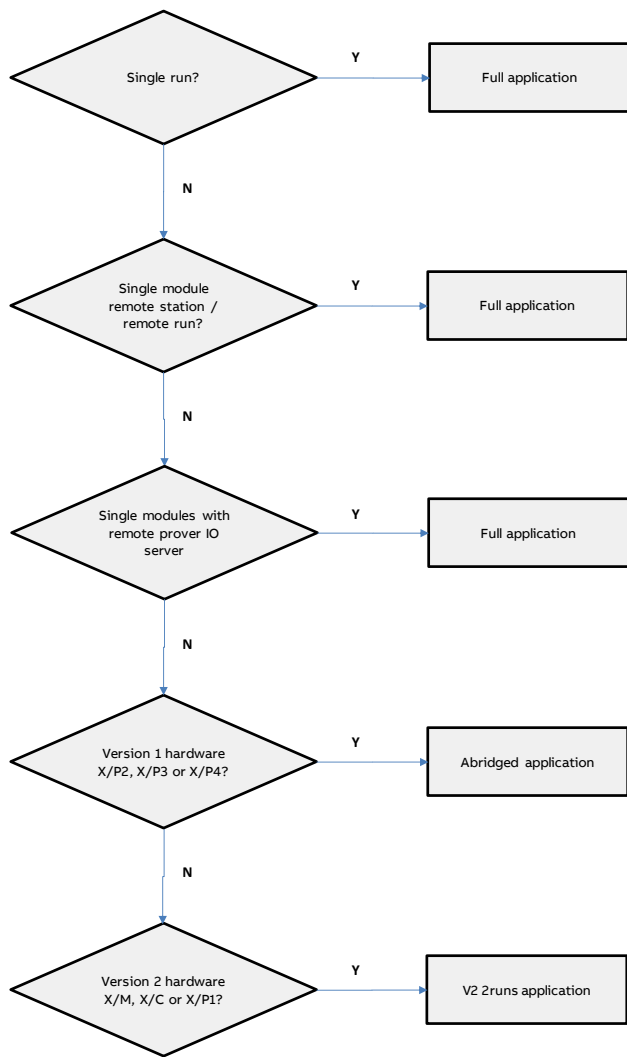

Figure 2: Flow chart for application selection

Input signals

The application can process one or more liquid meter runs. The following type of I/O can be configured:

- Flow meter input
- Process inputs
- Status inputs
- Densitometer inputs

Flow meter input

The application supports one flow meter input per meter run.

The following types of flow meter input are supported:

Input type	Meant for
Pulse input	Any flow meter that provides a single or dual pulse output that represents the volumetric or mass quantity. Typically used for: <ul style="list-style-type: none"> • Turbine meters • PD meters • Ultrasonic flow meters • Coriolis flow meters

Input type	Meant for
Smart input	Any flow meter that provides a Modbus, HART or analog output that represents the volumetric or mass quantity or flow rate. Typically used for: <ul style="list-style-type: none"> • Ultrasonic flow meters • Coriolis flow meters
Smart / pulse input	Typically used for ultrasonic and coriolis flow meters that provide both a 'smart' output and a pulse output. Either output signal may be selected as the primary signal. The secondary signal is used in case the primary signal fails.
Orifice	Orifice plates according to ISO-5167 / AGA-3
Venturi	Venturi tubes according to ISO-5167
V-cone	McCrometer V-cone and wafer cone meters
Venturi nozzle	Venturi nozzles according to ISO-5167
Long radius nozzle	Long radius nozzles according to ISO-5167
ISA 1932 nozzle	ISA 1932 nozzles according to ISO-5167

Table 2-1: Flow meter inputs

Process inputs

A process input is a live signal that is a qualitative measurement of the fluid.

A process input can be any of the following types:

- Analog input (0-20 mA, 4-20 mA, 0-5 Vdc, 1-5 Vdc)
- PT100 input (only for temperature measurement)
- HART input
- Modbus input
- Fixed value

The following process inputs are supported:

Process input	Meant for
Meter temperature	Temperature at the flow meter. Either one single or two redundant temperature transmitters are supported. For differential pressure type of flow meters (orifice, venturi, V-cone, nozzle) either the temperature at the upstream or downstream tapping or the temperature at the downstream location, where the pressure has fully recovered, may be used.
Meter pressure	Pressure at the flow meter. Either one single or two redundant pressure transmitters are supported. For differential pressure type of flow meters (orifice, venturi, V-cone, nozzle) either the pressure upstream or downstream of the flow meter may be used.
Density temperature	Temperature at the point where the density measurement is taken. This can be at the meter run or at the header. This input is only used if there is a live density measurement, based on a densitometer or observed density process input.
Density pressure	Pressure at the point where the density measurement is taken. This can be at the meter run or at the header. This input is only used if there is a live density measurement, based on a densitometer or observed density process input.
Observed density	The measured density. This can be taken at the meter run or at the header. The application supports the following units for density / gravity: <ul style="list-style-type: none"> • Density [kg/m³] • Relative density / specific gravity [-] • API gravity [°API]
Standard density	Density at the reference conditions of temperature and pressure, typically 15°C and 0 bar(g). The same units are supported as for the observed density / gravity input.

Process input	Meant for
	Instead of calculating the standard density from a measured density the application can also take a direct input signal or use a constant value for the standard density.
BS&W	Base Sediment and Water input. Either taken at the meter run or at the header. Used to calculate the net standard volume.
Viscosity	Viscosity input. Either taken at the meter run or at the header. The viscosity value can be used for viscosity correction of turbine and PD flow meters.
Prover inlet and outlet temperature	The application supports separate prover inlet and outlet temperature inputs. If both are defined then the average of both transmitters is used in the calculations.
Prover inlet and outlet pressure	The application supports separate prover inlet and outlet pressure inputs. If both are defined then the average of both transmitters is used in the calculations.
Piston rod temperature	Applies to compact provers only.
Prover plenum pressure	Only applies to Brooks (Daniel / Emerson) compact provers

Table 2-2: Process inputs

Furthermore, the application supports 2 auxiliary temperature inputs, 2 auxiliary pressure inputs and 2 generic auxiliary process inputs, which may be used to read additional process values.

Digital status and command inputs

The application supports the following status and command inputs:

Status input	Purpose
Data validity input	Can be used in case the flow meter provides a status signal that indicates the validity of the flow meter signal. It is typically used by ultrasonic and coriolis flow meters in combination with a pulse signal. The input is used for alarming purposes and to control the accountable totals required for MID.
Flow direction input	Can be used to determine whether the forward or reverse totalizers must be activated.
Valve open input	Indicates if a valve is in the open position or not.
Valve closed input	Indicates if a valve is in the closed position or not.
Valve fwd input	Indicates if a 4-way valve is in the forward position or not.
Valve rev input	Indicates if a 4-way valve is in the reversed position or not.
Valve local / remote status input	Indicates whether a valve is controlled locally (on the valve itself) or remotely (from the flow computer)
Valve fault status input	Indicates whether a valve is in a valid or invalid position
4-way valve leakage	Used to detect a metering integrity problem during proving. Prove run will be aborted when the leakage signal is active while the sphere or piston is in the calibrated volume.
Prove detectors	Up to 4 prove detector signal inputs are available. In case of master meter proving based on pulses the first prove detector is used to start / stop master meter proving simultaneously on the master meter module and the module of the meter on prove.
Piston upstream indication	Only applies for Brooks (Daniel / Emerson) compact provers. Indicates that the piston is in the upstream position, so a new prove pass may be started.
Low nitrogen indication	Only applies for Brooks (Daniel / Emerson) compact provers. Indicates that nitrogen container (for adjusting the plenum pressure) is empty.
Sampler can full indication	May be used to indicate that a sample can is full
Serial mode indication	Signal that indicates that two meters (usually master meter and meter on prove) are in serial configuration, so

Status input	Purpose
	only one of the meter readings must be used in the station total. To be used on systems where the meters can be set in serial or parallel mode by means of a cross-over valve. The signal is to be connected to a position indication of the cross-over valve. The meters are in serial mode if the cross-over valve is not closed.
Batch end command	Command to end the current batch
Batch start command	Command to start a new batch
Print snapshot report command	Command to print a snapshot report

Additional status and command inputs may be used for user-defined functionality.

Densitometers

The application supports one or two densitometers for each meter run, or one or two densitometers at the header. In case of two densitometers the application uses the time period signal of the primary densitometer and switches to the backup densitometer in case the primary densitometer should fail.

Furthermore the application supports one densitometer for each prover and two auxiliary densitometers to read one or two extra density values for indicative purposes.

Densitometers of make Solartron, Sarasota and UGC and Anton Paar are supported.

Output signals

The application supports the following outputs

- Analog outputs
- Status outputs
- Pulse outputs

Analog outputs

Each flow module provides 4 analog outputs. Each output may be configured to output any process variable (e.g. the volume flow rate or the meter temperature) or a PID control output.

The application supports flow / pressure control for each individual meter run, or for the station as a whole. One analog output per PID loop is used for controlling the corresponding flow control / pressure control valve.

Analog output	Purpose
Flow and process values	To output the actual flow rate, density, pressure, temperature, etc.
PID control	For flow / pressure control

Pulse outputs

The application supports the configuration of up to 4 pulse outputs per flow module to drive electro-mechanical counters. Alternatively the pulse outputs can be used for sampling control.

Digital status and command outputs

The application supports the following digital outputs:

Status output	Purpose
Valve commands	Valve open / close or forward / reverse commands.

Status output	Purpose
Sampler pulse command	Command to the sampler to grab one sample
Prove start command	Only applies for generic (Calibron / flow MD) small volume, uni-directional ball provers and master meter proving based on pulses. Command to start the prover or, in case of master meter proving, to simultaneously start / stop pulse counting on the master meter module and the module of the meter on prove.
Brooks run command	Only applies for Brooks compact provers
Plenum pressure charge / vent commands	Only applies for Brooks compact provers
Can selection output	Selects a sample can
Flow direction output	Indicates that the reverse totals are active
Batch end indication	Indicates that a batch has been ended
FC duty status	Only applicable in case of a pair of redundant flow computers. Indicates that the flow computer is on duty.

Additional status and command outputs may be used for user-defined functionality.

Pulse outputs

The application supports the configuration of up to 4 pulse outputs per flow module to drive electro-mechanical counters. Alternatively the pulse outputs can be used for sampling control.

Batch operation

The flow computer maintains separate totalizers and averages to support batch operations. The flow computer performs batching either for each meter run individually or for all meter runs at once (i.e. at station level). Batches can be ended on operator command, or automatically based on a product interface change, at a daily or monthly basis or based on a set of scheduled dates. A stack of 6 batches can be pre-defined.

The meter ticket of the previous batch can be recalculated based on new standard density, BS&W and meter factor values.

Proving functionality

The application supports the following types of proving:

- Bi-directional sphere prover
- Uni-directional sphere prover
- Brooks (Daniel / Emerson) compact prover
- Calibron / Flow MD small volume prover
- Master meter proving

For small volume sphere provers, i.e. with a proved volume of less than 10000 meter pulses as in accordance with API standards, there is the option to apply double chronometry (i.e. pulse interpolation).

The application supports a common detector input as well as 2 separate inputs for the start and stop detector switches. Also the usage of a 2nd stop detector is supported, leading to 2 calibrated volumes, one for smaller and one for larger meters.

Also a 2nd start detector may be configured. Depending on the detector configuration up to 4 separate calibrated prover volumes can be selected.

The number of required successful prove runs and the passes per run can be set, as well as the repeatability limit. A repeatability check is performed either on the calculated meter factor or on the number of counted pulses. Either a fixed or a dynamic repeatability limit can be applied to determine when the required number of successful runs has been reached. The dynamic limit is in accordance with the method described in API 4.8 appendix A.

Master meter proving can be executed based on pulse counting or on totalizer latching. In the first case the meter on prove and master meter volumes are calculated from the pulse counts of both meters. In the second case the totalizers are calculated from the latched cumulative totalizers at the start and end of the prove.

Control features

Sample control

The application supports control of samplers. Sampler control can be configured either on run level (separate samplers for individual meter runs) or at station level (one sampler for the whole station consisting of multiple runs).

Single can samplers are supported, as well as twin and multiple can samplers (up to 16 cans). Several algorithms can be used for determining the time or metered volume between grabs. Also several mechanisms are available for can selection (f.e. based on product or based on customer) and can switching (f.e. at can full status or at batch end). Optionally logic for sampler cleaning can be enabled in order to flush the sampler when switching to a different sample can.

Valve control

The application provides control of run inlet and outlet valves, run to prover valves, a prover 4-way valve and a prover outlet valve. This includes logic to manually open or close the valves, detailed status info and the generation of valve failure and travel timeout alarms.

Additional valve sequencing logic can be defined using the Flow-Xpress configuration software through additional Calculations. Examples are to be found in the application file 'Calculation Examples.xls'.

Flow / pressure control

The application supports PID control for Flow / Pressure Control Valves. PID control can be configured either on run level (separate control valves for individual meter runs) or at station level (one control valve for the whole station consisting of multiple runs). Furthermore a separate prover control valve can be controlled.

PID control can be configured as flow control, pressure control, or flow control with pressure monitoring

Loading control

If the Flow-X can be provided with an extended application that includes loading control.

Loading control allows for standalone control of loading or offloading of trucks, railcars, ships etc., including LACT systems.

Loading control can be seen as an upper layer of loading logic that can control:

- Loading data entry
- Loading permissives
- Batch control
- Inlet and outlet block valves
- Flow control valve
- Pump
- Sampler
- Shakeout registration and batch recalculation
- Product evaluation
- Divert valve
- User lockout

Loading data entry

This controls the data that has to be entered by the user / truck driver before loading can be started.

Data fields include:

- Truck and driver information
- Lease and operator information
- Ticket information
- Customer information
- Product data
- Batch data
- Sampler data
- Custom data (up to 25 fields)

Each data field can be configured as required data, which means that loading can't be started if the data has not been entered.

Loading permissives

Configurable permissives include:

- Load ground digital input
- Up to 4 additional digital inputs
- BS&W permissive (max. allowable BS&W)
- Up to 3 custom permissives

Loading can't be started if any of the configured permissives is not met. If a permissive gets false when loading is running, the load is aborted.

Batch control

The user can enter a batch size, which is the basis for the applied loading curve (see further below).

From the batch control display the user can start and stop a loading and finish the loading / print the loading ticket.

Block valve control

Optionally, loading control can automatically open an inlet valve and/or outlet valve at the start of the loading and close them at the end of the loading.

Flow control

The following types of flow control valves are supported by the loading logic:

- Analog control valve
- Digital control valve (set-stop valve)
- 2-stage control valve

The loading logic follows a 'loading curve', which allows for 3-step loading:

- Start loading at low flow rate
- Switch to high flow rate when the 'low flow at start amount' has been loaded
- Switch back to low flow rate when the loaded amount has increased to the batch size minus the 'low flow at end amount'
- Stop leading just before the batch size is reached (loaded amount equals batch size minus early end amount).

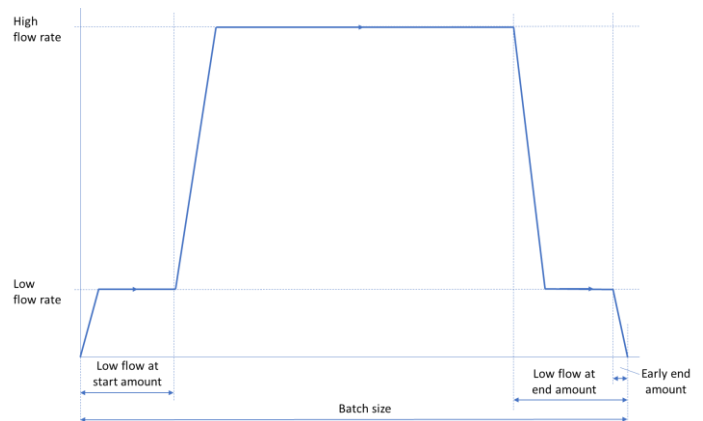

The above describes the loading curve in its most complete form. The 'low flow at start' and / or 'low flow at end' stages may be skipped if required (f.e. because a flow control valve is not available), such that loading starts directly at high flow and / or at the end the loading is closed directly from the 'high flow' stage.

After the loading has been ended, the user can finish loading by clicking the 'finish loading / print ticket' command.

The user can stop the loading at any time, regardless of the actual loading stage. At a manual stop command the flow control valve is gradually closed, and as soon as the flow rate reaches 0 the pump (if available) is stopped and the block valves (if available) are closed.

Alternatively, the user can give an 'emergency close' command, which directly closes the control valve and block valves and stops the pump altogether.

After a manual stop or emergency close, loading can be restarted during a configurable amount of time. If no (re-)start command has been given in time, loading is automatically finished and the loading ticket is generated.

Pump control

If configured, a pump is switched on at the start of the loading, a configurable time before the control valve is opened. The pump is stopped at the end of the loading, a configurable time after the control valve has been closed.

Additionally, a booster pump can be controlled. This can be just an extra pump, which is started together with the main pump or with a configurable delay, or a variable pump, which is given a setpoint based on the measured density.

Sampler control

The Flow-X's native sampler logic can be used together with the loading functionality. This includes various options from single can solutions up to 16 cans (one for each product, customer or customer / product combination).

Shakeout registration and batch recalculation

This creates the possibility to enter data from sample analysis. It makes use of the native batch recalculation functionality of the flow computer.

BS&W lockout

During loading, the actual BS&W value can be monitored, aborting the loading if the value gets too high. Additionally, a user can be temporarily 'locked out' after repeated aborts. The locked out user can't start another loading during a configurable time.

3 Operation

This chapter describes the operational features of the flow computer that are specific for the Flow-X Liquid Metric application.



General operational functions such as report printing, alarm acknowledgement, as well as descriptions of the LCD display, the touchscreen (Flow-X/P and Flow-X/C) and the web interface are described in manual IIA 'Operation and Configuration'.



Most of the displays described below are only visible after logging in with a username and password of security level 'operator (500)' or higher.

If no user has logged on, only a limited number of displays are visible, showing a short summary of process values, flow rates, cumulative totalizers and in-use gas composition.

In-use values

This display gives an overview of the actual process values, such as temperature, pressure and density, as well as the main calculation results, such as heating value and compressibility.



Display → In-use values

Flow rates

This display shows the actual flow rates.



Display → Flow rates

The following operational settings are available for the flow rates:

Process alarm limits

The limits in this section are used to monitor the flow rate. The flow computer gives a flow rate alarm when the actual flow rate passes any of these limits.

Hi hi limit	500	Limit for the flow rate high high alarm [unit/hr]*
Hi limit	500	Limit for the flow rate high alarm [unit/hr]*
Lo limit	500	Limit for the flow rate low alarm [unit/hr]*
Lo lo limit	500	Limit for the flow rate low low alarm [unit/hr]*
Rate of change limit	500	Limit for the flow rate rate of change alarm [unit/hr/sec]*

*Limits are based on the primary flow rate from the flow meter. Therefore, units are either [m³/hr] or [tonne/hr], depending on the meter type.

Product

Depending on the configuration, all meter runs are using one and the same (station) product, or all meter runs are using separate products.

The 'Product' display shows information on the product that is currently in use.

If multiple products have been configured, then the product to be used can be selected from this display.



Display → Product (, Run<x>)

Current - Product nr.	500	The current product number [1..16]
-----------------------	-----	------------------------------------

Temperature

A separate operator display is available for every temperature transmitter.



Display → Temperature

Depending on the actual configuration, displays are available for the following temperature inputs:

- <Run>, Meter temperature
- <Run>, Density temperature
- Station, Density temperature
- Prover A/B inlet temperature
- Prover A/B outlet temperature
- Prover A/B rod temperature
- Prover A/B density temperature
- Auxiliary temperature 1/2

The following operational settings are available for each applicable temperature input:

Override

These settings can be used to switch between the (live) process value and a user definable fixed override value. The flow computer generates an alarm if the override value is in use.

During normal operation the use of override values should be avoided. On MID compliant systems, using an override value means that the accountable totalizers are stopped and the non-accountable totalizers are activated.

Override	500	Temperature override selection
		0: Disabled
		The live input value is used for the calculations
		1: Enabled
		The override value is used for the calculations
Override	500	Temperature override value [°C]

Process alarm limits

The limits in this section are used to monitor the temperature. The flow computer generates an alarm if the temperature passes any of these limits.

Hi hi limit	500	Limit for the temperature high high alarm [°C]
Hi limit	500	Limit for the temperature high alarm [°C]
Lo limit	500	Limit for the temperature low alarm [°C]
Lo lo limit	500	Limit for the temperature low low alarm [°C]
Rate of change limit	500	Limit for the temperature rate of change alarm [°C/sec]

Transmitter A/B

Only applicable to the meter temperature. If the meter run is equipped with two (redundant) meter temperature transmitters, then each individual transmitter can be put out of service. If one transmitter is out of service the flow computer generates an alarm and uses the (live) value from the other transmitter.

If both transmitters are out of service (a situation that should be avoided during normal operation) the flow computer switches over to the last good, fallback or override value (depending on the configuration). On MID compliant systems this means that the accountable totalizers are stopped and the non-accountable totalizers are activated.

Meter temperature A/B out of service	500	Temperature transmitter A / B out of service selection
		0: Disabled
		The transmitter value is used for the calculations
		1: Enabled
		The transmitter value is not used for the calculations

Pressure

A separate operator display is available for every pressure input.



Display → Pressure

Depending on the actual configuration, displays are available for the following pressure inputs:

- <Run>, Meter pressure
- <Run>, Density pressure
- Station, Density pressure
- Prover A/B inlet pressure
- Prover A/B outlet pressure
- Prover A/B plenum pressure
- Prover A/B density pressure
- Auxiliary pressure 1/2

The following operational settings are available for each applicable pressure input:

Input units	1000	Pressure units
		1: Absolute
		The input value is an absolute pressure [bara]

2: Gauge
The input value is a gauge pressure [barg] (i.e. relative to the atmospheric pressure)

Override

These settings can be used to switch between the (live) process value and a user definable fixed override value. The flow computer generates an alarm if the override value is in use.

During normal operation the use of override values should be avoided.

Override	500	Pressure override selection
		0: Disabled The live input value is used for the calculations
		1: Enabled The override value is used for the calculations
Override	500	Pressure override value [bar]*

Process alarm limits

The limits in this section are used to monitor the pressure. The flow computer generates an alarm if the pressure passes any of these limits.

Hi hi limit	500	Limit for the pressure high high alarm [bar]*
Hi limit	500	Limit for the pressure high alarm [bar]*
Lo limit	500	Limit for the pressure low alarm [bar]*
Lo lo limit	500	Limit for the pressure low low alarm [bar]*
Rate of change limit	500	Limit for the pressure rate of change alarm [bar/sec]

*Either [bar(a)] or [bar(g)], depending on the selected **input units**

Transmitter A/B

Only applicable to the meter pressure. If the meter run is equipped with two (redundant) meter pressure transmitters, then each individual transmitter can be put out of service. If one transmitter is out of service the flow computer generates an alarm and uses the (live) value from the other transmitter.

If both transmitters are out of service (a situation that should be avoided during normal operation) the flow computer switches over to the last good, fallback or override value (depending on the configuration). On MID compliant systems this means that the accountable totalizers are stopped and the non-accountable totalizers are activated.

Meter pressure A/B out of service	500	Pressure transmitter A / B out of service selection
		0: Disabled The transmitter value is used for the calculations
		1: Enabled The transmitter value is not used for the calculations

Density

Depending on the configuration the following density displays may be available:

- Observed density
- Standard density
- Meter density
- Densitometer
- Densitometer selection



Display → Density

Observed density, standard density

The flow computer has separate operator displays for observed density and standard density. The observed density display is only visible in case of a live density input, f.e. a densitometer.

For observed density and standard density the following operational settings are available:

Override

These settings can be used to switch between the measured / calculated value and a user definable fixed override value. The flow computer generates an alarm if the override value is in use.

During normal operation the use of override values should be avoided. On MID compliant systems, using an override value means that the accountable totalizers are stopped and the non-accountable totalizers are activated.

Override	500	Density / gravity override selection 0: Disabled The live / calculated value is used for the calculations 1: Enabled The override value is used for the calculations
Override	500	Density/gravity override value (*)



The standard density override value is taken from the product table and can be configured through display:

Configuration, Products, (Product <x>)

Process alarm limits

The limits in this section are used to monitor the density / gravity. The flow computer generates an alarm if the density / gravity passes any of these limits.

Hi hi limit	500	Limit for the density/gravity high high alarm *
Hi limit	500	Limit for the density/gravity high alarm *
Lo limit	500	Limit for the density/gravity low alarm *
Lo lo limit	500	Limit for the density/gravity low low alarm *
Rate of change limit	500	Limit for the density/gravity rate of change alarm limit [* /sec]

*Unit depends on the selected **unit input type**: Relative density [-], API gravity [°API], density [kg/m³] for observed density, [kg/sm³] for standard density.

Meter density

Depending on the density configuration, the meter density (density at meter temperature and pressure) is calculated from the observed density or from the base density.

The meter density display shows the calculated meter density [kg/m³], meter relative density [-] and API gravity [°API].

Densitometers

Depending on the density configuration the following densitometer displays may be available:

- Run: one or two densitometers (A / B)
- Station: one or two densitometers (A / B)
- Prover A: one densitometer
- Prover B: one densitometer
- Auxiliary densitometer 1/2

For each densitometer the following settings are available:

Override

The time period inputs of the densitometers can be manually overridden. This feature is meant for test purposes only. It requires security level 1000 ('Engineer'). During normal operation the use of override values should be avoided.

The flow computer generates an alarm if the override value is in use. On MID compliant systems, using an override value means that the accountable totalizers are stopped and the non-accountable totalizers are activated.

Time period override	1000	Time period input override selection 0: Disabled The live input value is used for the calculations 1: Enabled The override value is used for the calculations
Time period override	1000	Time period input override value [microseconds]

Process alarm limits

The limits in this section are used to monitor the densitometer time period signal. The flow computer generates an alarm if the time period passes any of these limits.

Hi hi limit	500	Limit for the time period input high high alarm [microseconds]
Hi limit	500	Limit for the time period input high alarm [microseconds]
Lo limit	500	Limit for the time period input low alarm [microseconds]
Lo lo limit	500	Limit for the time period input low low alarm [microseconds]
Rate of change limit	500	Limit for the time period input rate of change alarm [microseconds /sec]

Densitometer selection

If two (redundant) densitometers are available, then a separate ‘Densitometer selection’ display is available, which can be used to specify which densitometer value is used in the calculations.

Densitometer select mode	500	Densitometer selection mode.
		1: Auto-A Densitometer B is only used if densitometer A fails and densitometer B is healthy. Densitometer A is used in all other cases.
		2: Auto-B Densitometer A is only used if densitometer B fails and densitometer A is healthy. Densitometer B is used in all other cases.
		3: Manual-A Always use densitometer A irrespective of its failure status
		4: Manual-B Always use densitometer B irrespective of its failure status

BS&W

A BS&W (Base Soil and Water) display is available if a BS&W input has been configured.



The BS&W display contains the following operator settings:

Override

These settings can be used to switch between the (live) process value and a user definable fixed override value. The flow computer generates an alarm if the override value is in use.

During normal operation the use of override values should be avoided. On MID compliant systems, using an override value means that the accountable totalizers are stopped and the non-accountable totalizers are activated.

Override	500	Override selection
		0: Disabled The live value is used for the calculations
		1: Enabled The override value is used for the calculations
Override	500	Override value [%vol]

Process alarm limits

The limits in this section are used to monitor the BS&W value. The flow computer generates an alarm if the BS&W value passes any of these limits.

Hi hi limit	500	Limit for the BS&W high high alarm [%vol]
Hi limit	500	Limit for the BS&W high alarm [%vol]
Lo limit	500	Limit for the BS&W low alarm [%vol]
Lo lo limit	500	Limit for the BS&W low low alarm [%vol]
Rate of change	500	Limit for the BS&W rate of change alarm [%vol/sec]

limit

Viscosity

A viscosity display is available if a viscosity input has been configured.

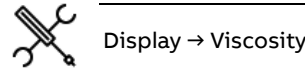

The viscosity display contains the following operator settings:

Override

These settings can be used to switch between the (live) process value and a user definable fixed override value. The flow computer generates an alarm if the override value is in use.

During normal operation the use of override values should be avoided. On MID compliant systems, using an override value means that the accountable totalizers are stopped and the non-accountable totalizers are activated.

Override	500	Override selection
		0: Disabled The live / calculated value is used for the calculations
		1: Enabled The override value is used for the calculations
Override	500	Override value [cSt]

Process alarm limits

The limits in this section are used to monitor the viscosity. The flow computer generates an alarm if the viscosity passes any of these limits.

Hi hi limit	500	Limit for the viscosity high high alarm [cSt]
Hi limit	500	Limit for the viscosity high alarm [cSt]
Lo limit	500	Limit for the viscosity low alarm [cSt]
Lo lo limit	500	Limit for the viscosity low low alarm [cSt]
Rate of change	500	Limit for the viscosity rate of change alarm [cSt/sec]

Batching

The 'Batch' section contains displays to start and end a batch, to define the batch stack, to recalculate the previous batch and to view the current and previous batch data.

Batch control

Depending on the configuration, a batch is defined for each separate meter run, or for a whole station consisting of multiple meter runs.



Display → Batch, Run <x>, Batch control

Display → Batch, Station, Batch control

With <x> the number of the meter run

Meter factor override	500	Only applicable if Implement meter factor retroactively is enabled. The value entered here will be used as meter factor for the whole batch. If left empty, the last proved meter factor will be used (even if the prove was done during the batch).
Recalc. batch meter factor input type	1000	Only applicable if Implement meter factor retroactively is enabled. Defines whether the meter factor or meter error has to be filled in. 1: Meter factor [-] 2: Meter error [%]
Standard density override	500	Only applicable if Implement standard density retroactively is enabled. The value entered here will be used as standard density for the whole batch. The original standard density (batch average) will be used if left empty.
Recalc. batch standard density input unit	1000	Only applicable if Implement standard density retroactively is enabled. Unit to be used for the entered standard density 1: Relative density [-] 2: API gravity [°API] 3: Density [kg/sm ³]
BS&W override	500	Only applicable if Implement BS&W retroactively is enabled. The value [%] entered here will be used as BS&W value for the whole batch. The original BS&W (batch average) will be used if left empty.
Batch end command	500	Ends the current batch. Command may be disabled depending on the actual status (e.g. flow rate > 0) and system settings (e.g. batch end only allowed when current batch has a batch volume > 0).

Batch definition

The settings in this section are used to define the current batch.

Current - Batch ID	500	The alpha-numeric identification of the current batch
Current - Batch size	500	The target batch size expressed in gross volume [m ³]. When the batch amount reaches this volume, then a 'batch size reached alarm' is given. A value of 0 m ³ disables this function.
Current - Product nr.	500	The product number [1..16] of the current batch. The corresponding product name is shown automatically when a product number is chosen.
Current - Customer nr.	500	The customer number [1..16] of the current batch (if applicable). The corresponding customer name is shown automatically when a customer number is chosen.
Batch preset	500	Batch preset warning volume [m ³]

warning volume	When the batch amount reaches the batch size minus this warning volume, then a 'batch preset warning volume reached' alarm is given. A value of 0 m ³ disables this function.
----------------	---

Batch commands

By default the 'Batch end command' closes the current batch and directly starts a new batch.

Optionally a 'Batch start command' can be configured. In that case a 'Batch start command' has to be given to start a new batch. Between the batch end command and the batch start command the batch totals are not running.

Batch start command	500	Starts a new batch.
Batch end command	500	Ends the current batch (see above). If the batch stack has been defined, the stack is shifted one position, so that the next batch in line will be activated.
Batch end -no batch stack shift command	500	Ends the current batch without shifting the batch stack.

Defining the batch stack

Depending on the configuration, a batch stack can be defined for each separate meter run, or one generic batch stack for a station consisting of multiple meter runs.

A batch stack contains up to 6 batches (seq. #1 to #6). Seq. #1 is the active batch that is currently being processed. Seq #2 to #6 are predefined batches that are waiting to be processed.



Display → Batch, Run <x>, Batch stack

Display → Batch, Station, Batch stack

With <x> the number of the meter run

Each batch (seq #1 to #6) is defined by the following settings:

Batch ID	500	The alpha-numeric identification of the batch
Product nr.	500	The product number [1..16] of the batch. The corresponding product name is shown automatically when a product number is chosen.
Customer nr.	500	The customer number [1..16] of the batch (if applicable). The corresponding customer name is shown automatically when a customer number is chosen.
Batch size	500	The target batch size expressed in gross volume [m ³]. When the batch amount reaches this volume, then a 'batch size reached alarm' is given. A value of 0 m ³ disables this function.

Batch stack commands

Delete seq. #	500	Deletes the selected batch from the batch stack
Insert before seq. #	500	Inserts a batch before the selected batch. The last batch from the batch stack will be deleted.

Scheduled batch ends



Display → Batch, Scheduled batch ends

Only available if **Automatic batch end on time** has been activated and set to 'Scheduled'.

Batch end date 1..5	500	Up to five days can be configured for automatic batch ends. The flow computer automatically generates a batch end at the scheduled days.
Batch end sampling volume 1..5	500	If sampling is enabled and the sampling method has been set to 'Flow (auto batch end)', then for each scheduled batch end a sampling volume can be entered. This volume represents the projected batch size and is used by the sample logic to calculate the volume between grabs, so that the sample can will be approximately full at the end of the scheduled batch.
Batch end sampling volume in-use	500	At the moment when an automatic batch end is generated, the corresponding sampling volume 1..5 is copied to the in-use sampling volume. In needed, this in-use volume can be modified / adjusted during execution of the batch.

Batch recalculation

The last 4 completed batches can be recalculated based on modified input data. This is useful in case of a sample can that is analyzed in a laboratory to determine the standard volume and / or BS&W content. As the analysis takes some time, the analysis data typically becomes available when the next batch has already been started. Batch recalculation makes it possible to recalculate the previous batch while the next batch is already running.

Another occasion when batch recalculation is feasible is when the meter is proved during the execution of a batch. Recalculating the batch after completion with the newly derived meter factor makes it possible to apply the new meter factor to the whole batch (and not only to the part of the batch that has been processed after the new meter factor has been determined).

Depending on the configuration, batch recalculation can be done on each meter run separately, or at once for a whole station consisting of multiple meter runs.

Batch recalculations can be repeated with the number of recalculations indicated on top of the recalculated meter ticket.



Display → Batch, Run <x>, Batch recalculation

Display → Batch, Station, Batch recalculation

With <x> the number of the meter run

Batch selected for recalculation	500	The batch to be recalculated 1: Last batch 2: Last batch - 1 3: Last batch - 2 4: Last batch - 3
Print recalculated meter ticket	500	Generates a new meter ticket based on the entered recalculation data

Standard density

Recalc. batch standard density input unit	1000	Unit to be used for the entered standard density 1: Relative density [-] 2: API gravity [°API] 3: Density [kg/sm3]
Recalc. batch standard density	500	New standard density to be used for recalculation. The unit depends on the selected 'Recalc batch standard density input unit'

BS&W

Recalc. batch BS&W	500	New BS&W value to be used for recalculation.
--------------------	-----	--

Meter factor

Recalc. batch meter factor input type	1000	Defines whether the new meter factor or meter error has to be filled in. 1: Meter factor [-] 2: Meter error [%]
Recalc. batch meter factor / error	500	New meter factor or meter error to be used for recalculation.



If the flow computer has been configured for bi-directional flow, then separate fields are available for entering the standard density, BS&W and meter factor values for recalculation of the forward and reverse totalizers.



If station batch recalculation has been enabled, then the new standard density, BS&W and meter factors for all separate meter runs can be entered in one display.

Proving

The application supports the following types of proving:

- Bi-directional ball prover
- Uni-directional ball prover
- Calibron / Flow MD small volume prover
- Brooks compact prover
- Master meter proving

Displays to view the status of the current and previous prove sequence can be accessed through option "Proving" from the main menu.

The prove displays are only available if proving has been configured.

Proving operation

The proving operation display shows the actual prove status and contains commands to start or abort a prove sequence and to accept or reject the proved meter factor.

A prove can only be started if the prove permissive is 'On'. The prove permissive is 'Off' if:

- Communication to the meter on prove is down (ultrasonic / Coriolis meter)
- Communication to the master meter is down (master meter proving with ultrasonic / Coriolis master meter)
- The 4-way valve is in manual control (bi-directional ball prover only)
- The 4-way valve is in local control (bi-directional ball prover only)
- The 4-way valve is not at the reverse position (bi-directional ball prover only)
- Low nitrogen detected (Brooks compact prover only)
- A Custom permissive condition is not met (f.e. a valve must be opened or closed). This is no standard functionality, but it may have been added by the user.

If the prove permissive gets off during a prove sequence, then the sequence is aborted.

A prove is also aborted if the prove integrity gets 'Off' during a prove pass. This is the case if:

- A 4-way valve leak is detected
- A custom integrity condition is not met (this is no standard functionality, but it may have been added by the user).

The resulting meter factor can be configured to be accepted automatically or manually. In the latter case, after finishing of the prove sequence the flow computer waits for the operator to accept or reject the meter factor.

The meter factor is accepted, provided that:

- A normal (no trial) prove sequence has been started

- The prove sequence has been completed successfully
- The new meter factor has passed all test criteria
- In case of manual acceptance: The operator issues the 'accept meter factor' command before the acceptance time-out period has elapsed



Display → Proving, Proving operation

The following settings / commands related to proving are available:

Meter to be proved	500	Number of the meter to be proved. Only applicable if multiple meters are involved.
--------------------	-----	--

Prove commands

Start prove sequence	500	Command to start a prove sequence for the selected meter.
Accept meter factor	500	Command to accept the proved meter factor
Reject meter factor	500	Command to reject the proved meter factor.
Abort prove sequence	500	Command to abort an active prove sequence

Trial prove

Start trial prove	500	Command to start a trial prove sequence for the selected meter. A trial prove is the same as a normal prove except that the new meter factor will not be accepted.
-------------------	-----	--

In-use prover

One or two provers can be configured. Both provers can be of any of the types described above (including master meter proving).

In case of two provers, the settings in this section can be used to switch between the provers.

Selected prover	500	The prover to be used. 1: Prover A 2: Prover B
Reset prover in-use state	500	Command to 'free' the selected prover. Normally this command is not needed.

Prove required flags

For each flow meter the flow computer can be configured to maintain a number of prove required flags, that indicate that a new prove is required because of a change of flow rate, standard density, temperature, pressure, viscosity, or because a maximum flow between proves has been exceeded.



Display → Flow meter, Run <x>, Meter factor, Prove required flags

This display is only available if parameter **Prove required flags** is set to 'enabled' (Display → Configuration, Flow meter, Run <x>, Meter factor setup).

Flow rate

Prove required flag on flow rate change	500	If enabled, the 'prove required - flow rate change' flag will be raised if the flow rate deviates from the last prove flow rate by more than the threshold value AND the relative deviation is larger than the flow rate change percentage. 0: Disabled 1; Enabled
Flow rate change percentage	500	The prove required flag will be raised if the flow rate differs from the last meter proving flow rate by more than this percentage.
Flow rate change threshold	500	The prove required flag will be raised if the flow rate differs from the last meter proving flow rate by more than this amount. Unit [m ³ /hr] in case of a volume flow meter, [tonne/hr] in case of a mass flow meter.
Flow rate deviation period	500	The flow rate change must be sustained for at least this period [min] before the prove required flag is raised.

Flow between proves

Prove required flag on flow between proves	500	If enabled, the 'prove required - flow between proves' flag will be raised if the indicated volume / mass since the last accepted prove is larger than the 'maximum flow between proves' value. 0: Disabled 1; Enabled
Maximum flow between proves	500	Maximum volume / mass that is allowed to flow through the meter before a new prove has to be conducted. Unit [m ³] in case of a volume flow meter, [tonne] in case of a mass flow meter.

Standard density

Prove required flag on std. density change	500	If enabled, the 'prove required - std. density change' flag will be raised if the standard density deviates from the last prove standard density by more than the threshold value. 0: Disabled 1; Enabled
Standard density change threshold	500	The prove required flag will be raised if the standard density differs from the last meter proving standard density by more than this amount [kg/sm ³].
Standard density deviation period	500	The standard density change must be sustained for at least this period before the prove required flag is raised.

Temperature

Prove required flag on temperature change	500	If enabled, the 'prove required - temperature change' flag will be raised if the temperature deviates from the last prove temperature by more than the threshold value. 0: Disabled 1; Enabled
Temperature change threshold	500	The prove required flag will be raised if the temperature differs from the last meter proving temperature by more than this amount [°C].
Temperature deviation period	500	The temperature change must be sustained for at least this period before the prove required flag is raised.

Pressure

Prove required flag on pressure change	500	If enabled, the 'prove required - pressure change' flag will be raised if the pressure deviates from the last prove pressure by more than the threshold value. 0: Disabled 1; Enabled
Pressure change threshold	500	The prove required flag will be raised if the pressure differs from the last meter proving pressure by more than this amount [bar].
Pressure deviation period	500	The pressure change must be sustained for at least this period before the prove required flag is raised.

Viscosity

Prove required flag on viscosity change	500	If enabled, the 'prove required - viscosity change' flag will be raised if the viscosity deviates from the last prove viscosity by more than the threshold value. 0: Disabled 1; Enabled
Viscosity change threshold	500	The prove required flag will be raised if the viscosity differs from the last meter proving viscosity by more than this amount [cSt].
Viscosity deviation period	500	The viscosity change must be sustained for at least this period before the prove required flag is raised.

Optionally, the flow computer can be configured to generate an alarm when a prove required flag is raised.

Valve control

The flow computer supports control of the following valves:

For each run:

- Run inlet valve
- Run outlet valve
- Run to prover valve

For each prover A/B:

- Prover 4-way valve (bi-directional prover only)
- Prover outlet valve

For each valve a separate display is available. Only the displays of those valves that have been enabled are shown.



Display → Valve control

The following settings and commands are available for each valve:

Manual control

Auto/manual mode	500	Toggles the valve between automatic and manual mode of operation. The automatic mode of operation is meant for systems where valve sequencing is applied, either through the flow computer itself or by an external device (e.g. the DCS or the supervisory computer). 1: Auto 2: Manual
Manual open command*	500	Issues the command to open the valve. Only accepted if the valve operates in manual mode and the valve open permissive is high.
Manual close command*	500	Issues the command to close the valve. Only accepted if the valve operates in manual mode and the valve close permissive is high.

*For prover 4-way valves 'open' and 'close' have to be read as 'forward' and 'reverse'.

Flow / pressure control

The flow computer supports flow control, pressure control and flow control with pressure monitoring. Depending on the configuration the appropriate display is shown.



Display → Flow control (, Run<x>)

Display → Flow control, Station

Display → Flow control, Prover

Display → Pressure control (, Run<x>)

Display → Pressure control, Station

Display → Pressure control, Prover

With <x> the number of the meter run

The following settings and commands are available for each flow control / pressure control valve:

Flow control

These settings are only available for flow control valves (with or without pressure monitoring).

Flow control setpoint type	500	Toggles between the auto setpoint and the user setpoint. The auto setpoint is meant for systems where the flow rate setpoint is determined by the flow computer itself or by an external device (e.g. to implement a loading curve with several low / high flow rate stages). 1: Auto 2: User
Flow control - user setpoint	500	The control loop will try to achieve this setpoint value provided that the setpoint type is set to 'User' and Manual control mode is not enabled. The unit is the same as the controlled process value: [m3/hr] for volume flow meters and [tonne/hr] for mass flow meters. In case of flow control at the prover with option 'Copy setpoint from run FCV' enabled, the setpoint is overwritten by the setpoint from the run flow control valve.

Pressure control

These settings are only available for pressure control valves.

Pressure control - setpoint	500	The control loop will try to achieve this setpoint value provided that Manual control mode is not enabled. The unit is the same as the controlled process value [bar(g)] or [bar(a)], depending on the configured pressure control units.
-----------------------------	-----	---

Manual control

Manual control mode	500	Enables or disables manual control. 0: Disabled Manual control is disabled. The PID control algorithm is enabled. The valve position follows the manual output %. 1: Enabled Manual control is enabled. The PID control algorithm is disabled. The valve position is controlled by the PID algorithm, which tries to achieve or maintain the flow rate or pressure setpoint.
Manual control output	500	The valve position will be set to this value [%] if Manual control mode is enabled

Sampler control

The following sampling modes are supported:

- Single can
- Twin can
- Multiple cans

The flow computer both supports flow-proportional and time-proportional sampling.

Flow-proportional sampling can be based on:

- A fixed volume between grabs
- An estimated total metered volume to be sampled until the can is full
- The batch size from the batch stack
- The sample volume from the scheduled batch ends
- The nomination of the in-use can

Time-proportional sampling can be based on:

- A fixed time between grabs
- An estimated end time when the sample can should be full
- A time period during which the sample can should be filled

The can fill indication can be based on the actual grab count, a digital input (indicating the can full state) or an analog input. The sampler may be stopped automatically when the can is full. Automatic can switchover is also supported.

The sampling logic contains a virtual pulse reservoir which will be filled if the required sample rate is too high for the pulse output. The amount of grabs in the sampler reservoir is limited by a configurable limit. A 'Grabs lost' alarm is generated when the limit is reached. Another limit value (configurable) is used to generate an 'Overspeed alarm' when more pulses are generated than the sampler can handle.

Operator commands are available to start and stop sampling, to reset the whole sampler and to reset a specific can only.

Displays to control and monitor the sampler can be accessed through option "Sampling" from the main menu. The sampling displays are only visible if sampler control has been enabled.



Display → Sampling, Sampler control

Start sampler	500	Command to start the pulse output to the sampler and the accumulation of grabs in the grab counter.
Stop sampler	500	Command to stop the generation of pulses the accumulation of grabs in the grab counter.
Reset sampler	500	Resets the accumulated number of grabs of all available cans. Also implies a 'Stop sampler' command.
In-use can / Selected can	500	Shows the can that is currently in use. Depending on the configured can selection control mode*, this setting can be used to manually switch control to another can. Alternatively, the can is automatically selected by the flow computer sampling logic.

Can 1 / 2 / 3 / 4	500	Only available for specific can selection control modes*. Enables / disables can 1 / 2 / 3 / 4 (if available). A can that is disabled won't be used by the flow computer sampler logic. 0: Disabled 1: Enabled
Reset can	500	Command to reset the number of grabs in the can to 0. This effectively reports the can as 'empty'. This command can either be found on display: Sampling, Sampler control or on display: Sampling, Sampler cans, can <x> (with x = can number). Not applicable if Can fill indication method is 'Analog input'.

*Twin can modes and multiple cans (switch at batch end) and multiple cans (select can) modes.

Test

Grab test	1000	Command for testing the sampler strobe. Issues one pulse (=one grab) to the in-use sampler strobe. Can only be used when sampling is inactive.
-----------	------	---

Sample settings



Display → Sampling, Sample settings

The settings on this display can be used to define the frequency of the sample pulses.

For some sample methods the sample frequency is calculated from other settings (e.g. batch size, or can nomination), which can be found on a different display, as indicated below.

Flow (fixed value)

Gives a sample pulse each time when a certain (fixed) volume has been metered.

Volume between grabs fixed value	500	Volume [m3] that needs to be accumulated before the next grab command is issued.
----------------------------------	-----	--

Flow (estimated volume)

Calculates the volume between grabs based on an expected total metered volume, such that the can will be full when this volume has been metered.

Expected total volume	500	Estimated total volume [m3] to be metered in order to fill the can.
-----------------------	-----	---

Flow (batch volume)

Calculates the volume between grabs based on the batch size [m3], such that the can will be full when the batch is completed.

Uses the batch size, which can be found on the displays: batch, batch control and batch, batch stack

Flow (auto batch end)

Only applicable if **Automatic batch end on time** has been activated and set to 'Scheduled'.

Calculates the volume between grabs based on the projected sample volume [m3] from the scheduled batch ends, which can be found on display: Batch, Scheduled batch ends

Flow (can nomination)

Calculates the volume between grabs based on the nomination [m3] of the in-use can, which can be found on display: Configuration, Sampler control, Can settings, can <x>

Time (fixed value)

Gives a sample pulse each time when a certain (fixed) time has passed.

Time between grabs fixed value	500	Interval at which grab commands (pulses) are issued [s].
-----------------------------------	-----	---

Time (expected end time)

Calculates the time between pulses based on an expected end date and time, such that the can will be full at that moment.

Expected end time for sampling	500	Date / time when the sample can has to be full to the target fill percentage.
--------------------------------------	-----	--

Time (period)

Calculates the time between pulses based on a period [hours], such that the can will be full when this period has passed.

Can fill period	500	Period of time [hr] in which the can has to be filled to the target fill percentage.
--------------------	-----	---

Loading control

The optional 'Loading' section contains displays to control a loading or unloading, including loading data entry, loading start / stop, batch calculation. This section also provides detailed information on the loading state, batch size, flow rates, permissives, pump status, etc.

Loading state

The following loading states are discerned:

Ready for loading	Loading is idle: block valves closed, control valve in no-flow position, pump not running, no flow, batch inactive
Starting	Pump is started, block valves are opened, batch is opened
Low flow start	Loading at low flow rate. Control valve opened at low flow setpoint. Loading will remain in this state until the 'low flow at start amount' is reached.
High flow	Loading at high flow rate. Control valve opened at high flow setpoint. Loading will remain in this state until the loaded amount equals the batch size minus the 'low flow at end amount'.
Low flow end	Loading at low flow rate. Control valve opened at low flow setpoint. Loading will remain in this state until the loaded amount equals the batch size minus the 'Early end amount'.
Closing	Control valve is moving to no flow position
Shutdown	Control valve has reached no-flow position, flow has stopped, but pump is still running and block valves are still open
Completed	Pump has stopped, block valves are closed. Loading may be restarted within the 'restart time'. If not restarted within this time, loading will be automatically finished.
Aborted	Loading has been aborted due to an emergency close or because one or more permissives have been switched off. Pump is stopped, block valves are closed. Control valve frozen. Loading may be restarted within the 'restart time'. If not restarted within this time, loading will be automatically finished.
Unauthorized loading	Loading is supposed to be idle, but the meter is detecting flow.
Enter density and BS&W	Loading has been finished, but system is still waiting for the shakeout density and / or BS&W to be entered.

Loading control

The loading control display shows all information needed to control a loading. From this display, the main loading data can be entered and loading commands can be given.



Display → Loading, Run <x>, Loading control

With <x> the number of the meter run

Start loading command	500	Command to start the loading. Before loading can be started, all permissives must be 'On'. Depending on the configuration, these may include data fields that have to be entered, ground and other connections that have to be connected and other conditions that have to be met. If any permissive is not met, loading can't be started. The start loading command can also be used to restart loading after a stop, abort or emergency close. To be able to restart the loading, all loading
-----------------------	-----	---

Stop loading command	500	permissives must (again) be met. Restarting is only possible within a configurable restart time. Command to stop the loading. This will stop loading in an orderly way: First the control valve (if available) is controlled down to zero flow. A configurable time after zero flow has been reached the pump (if available) is stopped and the block valve(s) (if available) are closed.
Finish loading / print ticket command	500	Command to finish the loading and to generate the loading ticket. The command can only be used if loading is in the 'Completed' state (valves are closed, pump is not running, flow rate = 0).
Emergency close command	500	Immediately aborts the loading. Command should only be used in cases of emergency. Pump is stopped immediately and block valves are closed.

Batch size

This section is used to define the batch size and gives information on loading progress.

Batch size	500	Expected loading quantity. Unit is [m3] or [ktonne], based on the configured batch quantity type. The batch size is the basis of the loading curve to be followed and, amongst others, defines when loading switches from 'high flow' to 'low flow at end' and from 'low flow at end' to 'closing'.
------------	-----	---

Flow rate

This section gives information on flow rate and flow control setpoint.

Loading permissive

This section shows the overall loading permissive. More detailed information on individual permissives can be found on the loading permissives display.

Pump state

This section gives information on the status of the pump and booster pump (if available).

Recalculation

In this section, the shakeout density and BS&W can be entered and the recalculated ticket can be printed.

Shake-out standard density	500	Standard density [kg/m3] from product analysis. Used for batch recalculation. Needs to be a value between 0 and 2000 kg/m3.
Shake-out BS&W	500	BS&W [%] from product analysis. Used for batch recalculation. Needs to be a value between 0 and 100 %.
Calculate & print ticket command	500	Calculates and prints the ticket based on the shake out values, provided that these values are valid.



The loading control logic is to be seen as an add-on on the native flow computer functionality and makes use of the flow computer's batch control and flow control capabilities. Please be cautious not to interfere into the logic by manually influencing batch control or flow control, as this will confuse the loading sequence.

Loading data

The loading data display can be used to enter detailed loading data that is registered with the batch and printed on the loading ticket.



Display → Loading, Run <x>, Loading data

Depending on the configuration, specific fields have to be completed before a loading can be started. Other fields are facultative.

Data fields may include:

Truck data

- Driver nr.
- Driver name
- Trucking company
- Truck number
- Trailer number

Lease and operator information

- Lease operator name
- Lease name
- Lease number
- Ticket operator number

Ticket information

- Ticket number
- Observed volume entry
- Observed BS&W entry
- Observed density entry
- Observed pressure entry
- Observed temperature entry

Customer information

- Customer number [1-16]

Max. 16 customers can be defined. The corresponding customer name is automatically retrieved.

Product information

- Product number [1-16]

Max. 16 products can be defined. The corresponding product name is automatically retrieved.

The selected product number defines the calculation standard used.

Batch data

- Batch ID
- Batch size [m3] or [tonne]

Sampler data

- Sample can number [1-16]

Max. 16 sample cans can be defined. The corresponding sample can ID is automatically retrieved.

The sample can number defines to which sample can the samples are lead.

Custom loading data

Up to 25 additional custom loading data fields can be configured.

Loading permissives

The loading permissives display gives a detailed overview of the actual permissive states.



Display → Loading, Run <x>, Loading permissives

Truck driver display

Optionally a dedicated 'truck driver' display can be enabled.



Display → Loading, Run <x>, Truck driver

This display contains condensed information for systems where a truck driver can control a loading without the help of an operator.

The display includes authorization, loading data entry, loading control and a summary of loading state information.

Transloader displays

Optionally dedicated 'transloader' displays can be enabled.



Display → Loading, Run <x>, Loading operator

Display → Loading, Run <x>, Ticket operator

These displays contain condensed information for systems where a loading operator and ticket operator work together (ticket operator enters the ticket information and loading operator controls the loading).

The ticket operator display contains detailed ticket information and a summary of the batch data and loading state, whereas the loading operator display contains more detailed data to control the loading.

4 Configuration

This chapter describes the configuration items of the flow computer that are specific for the Liquid Metric application.

Introduction

The configuration procedure for any Flow-X flow computer is described in manual IIA- Operation and Configuration.

The procedure basically consists of the following steps:

- Setting up the flow computer device
- Configuring the HART and communications devices
- Defining the configuration settings
- Defining the reports and printers
- Defining the communication lists.

All the steps are described in manual IIA.

Manual IIA describes how to use the user interface to access the configuration settings. The actual settings however are dependent on the actual application. This chapter describes all the settings that are part the Liquid Metric application in a sequence that is logical from a configuration point of view.

I/O setup

A logical first step in the configuration process is to define the physical I/O points that involve all the transmitters, controllers and devices that are or will be physically wired to the I/O terminals of the flow computer.

Each flow module has the following amount of I/O.

- 6 analog inputs
- 2 PT100 inputs
- 4 analog outputs
- 16 digital I/O



The total number of pulse inputs, time period inputs, status inputs, pulse outputs, frequency outputs and status outputs is 16.

Later on in the configuration procedure the I/O points can be assigned to the related meter run, station and proving variables and statuses.

Analog inputs



Display → IO, <Module <x>, Configuration, Analog inputs, Analog input <y>

with <x> the number of the module to which the input is physically connected and <y> the relative input number.

Each flow module has 6 analog inputs. For each analog input the following settings are available:

Tag	600	Alphanumeric string representing the tag name of the transmitter, e.g. "PT-1001A". Only used for display and reporting purposes.
Input type	1000	Type of input signal 1= 4-20 mA 2= 0-20 mA 3= 1-5 Vdc 4= 0-5 Vdc
Averaging	1000	The method to average the individual samples within every calculation cycle. 15 samples per second are taken, so with a cycle time of 500 ms 7 to 8 samples are available per cycle. 1= Arithmetic mean 2= Root mean square Enter '2: Root Mean Square' for differential pressure flow transmitters. Enter '1: Arithmetic Mean' for other transmitters
Full scale	1000	The value in engineering units that corresponds with the full scale value. Uses the basic FC units: e.g. [°C] for temperature, [bar(a)] or [bar(g)] for pressure, [kg/m ³] for density, [mbar] for differential pressure, [cSt] for viscosity, [m ³ /hr] for volume flow rate, [tonne/hr] for mass flow rate. If a transmitter is used that uses different units, the range has to be converted into the basic FC unit. E.g. for a 4-20 mA temperature transmitter with a

		range of -30..+80 [°C] the value 80 [°C] must be entered. For a temperature transmitter with a range of 0-300 [°F] the value 148.889 [°C] must be entered.
Zero scale	1000	The value in engineering units that corresponds with the zero scale value. Uses the basic FC units: e.g. [°C] for temperature, [bar(a)] or [bar(g)] for pressure, [kg/m ³] for density, [mbar] for differential pressure, [cSt] for viscosity, [m ³ /hr] for volume flow rate, [tonne/hr] for mass flow rate. If a transmitter is used that uses different units, the range has to be converted into the basic FC unit. E.g. for a 4-20 mA temperature transmitter with a range of -30..+80 [°C] the value -30 [°C] must be entered. For a temperature transmitter with a range of 0-300 [°F] the value -16.778 [°C] must be entered.
High fail limit	1000	The value as percentage of the total span, at which a high fail alarm is given. Should be between 100 and 112.5 % span. For a 4-20 mA transmitter this corresponds to 20 to 22 mA.
Low fail limit	1000	The value as percentage of the total span, at which a low fail alarm is given. Should be between -25 and 0 % span. For a 4-20 mA transmitter this corresponds to 0 to 4 mA.



Before physically connecting the analog signals to the flow computer, please make sure the analog input modes (voltage/current) and ranges are correctly configured. An incorrect configuration may cause damage to the inputs.

PT100 inputs



Display → IO, <Module <x>, Configuration, PT100 inputs, PT100 input <y>

with <x> the number of the module to which the input is physically connected and <y> the relative input number

Each flow module has 2 PT100 inputs that can be connected to a PT100 element. For each PT100 input the following settings are available.

Tag	600	Alphanumeric string representing the tag name of the transmitter, e.g. "TT-1001A". Only used for display and reporting purposes.
Input type	1000	Type of PT100 element 1: European (most commonly used) Alpha coefficient 0.00385 Ω/ Ω/°C As per DIN 43760, BS1905, IEC751 Range - 200..+850 °C 2: American Alpha coefficient 0.00392 Ω/ Ω/°C Range - 100..+457 °C
High fail limit	1000	The temperature in °C, at which a high fail alarm is given.
Low fail limit	1000	The temperature in °C, at which a low fail alarm is given.

Digital IO assign

Each flow module provides 16 multi-purpose digital channels that can be assigned to any type of input or output.



Display → IO, <Module <x>, Configuration, Digital IO assign, Digital <y>

with <x> the number of the module to which the output is physically connected and <y> the output number

Tag	1000	Alphanumeric string representing the tag name of the transmitter, e.g. "MOV-34010". Only used for display and reporting purposes.
Signal type	1000	Assigns the digital signal to a specific purpose 0 : Not used 1 : Digital input e.g. status input 2 : Digital output e.g. status output, control output 3 : Pulse input 1A meter or master meter pulse input single pulse / channel A of dual pulse 4 : Pulse input 1B meter or master meter pulse input channel B of dual pulse 5 : Time period input 1 for densitometers 6 : Time period input 2 7 : Time period input 3 8 : Time period input 4 9 : Pulse output 1 to drive an E/M counter or a sampler 10 : Pulse output 2 11 : Pulse output 3 12 : Pulse output 4 13 : Prover A common / start (A) common detector or 1 st start detector or master meter prove start / stop signal input 14 : Prover A 2nd start (B) 2 nd start detector 15 : Prover A stop (C) 1 st stop detector 16 : Prover A 2nd stop (D) 2 nd stop detector 17 : Prover bus pulse output A meter pulse A output to prover FC 18 : Prover bus pulse output B meter pulse B output to prover FC 19 : Prover bus pulse input A remote meter / master meter pulse input A for proving 20 : Prover bus pulse input B remote meter / master meter pulse input B for proving 21 : Prover B common / start (A) common detector or 1 st start detector or master meter prove start / stop signal input 22 : Prover B 2nd start (B) 2 nd start detector 23 : Prover B stop (C) 1 st stop detector 24 : Prover B 2nd stop (D) 2 nd stop detector 25 : Frequency output 1 26 : Frequency output 2 27 : Frequency output 3 28 : Frequency output 4 29 : Pulse input 2A only applicable to version 2 hardware 30 : Pulse input 2B only applicable to version 2 hardware 31 : Pulse input 3A only applicable to version 2 hardware 32 : Pulse input 3B only applicable to version 2 hardware 33 : Pulse input 4A

only applicable to version 2 hardware
34: Pulse input 4B
only applicable to version 2 hardware

Digital IO settings



Display → IO, <Module <x>, Configuration, Digital IO settings, Digital <y>

with <x> the number of the module to which the output is physically connected and <y> the output number

Polarity	1000	1: Normal 2: Inverted Refer to setting 'Input latch mode' for more details.
Input threshold level	1000	Each digital channel has 2 threshold levels, which are as follows (all relative to signal ground): Channels 1 through 8: 1: + 1.25 Volts 2: + 12 Volts Channels 9 through 16: 1: + 3.6 Volts 2: + 12 Volts
Input latch mode	1000	Only applicable if signal type is 'Digital input' 1: Actual 2: Latched If polarity = Normal & input latch mode = Actual then digital input is 0:OFF when signal is currently below threshold 1:ON when signal is currently above threshold If polarity = Normal & input latch mode = Latched then digital input is 0:OFF when signal has not been above threshold 1:ON when signal is or has been above threshold during the last calculation cycle If polarity = Inverted & input latch mode = Actual then digital input is 0:OFF when signal is currently above threshold 1:ON when signal is currently below threshold If polarity = Inverted & input latch mode = Latched then digital input is 0:OFF when signal has not been below threshold 1:ON when signal is or has been below threshold during the last calculation cycle
Output min. activation time	1000	Only applicable if signal type is 'Digital output' Minimum period of time that the signal will remain activated. After the minimum activation time has elapsed the output signal will remain activated until the control value becomes 0.
Output delay time	1000	Only applicable if signal type is 'Digital output' Period of time that the control signal must be high (> 0) without interruption before the output will be activated. If the control signal becomes 0 before the time has elapsed, then the output signal will not be activated The value 0 disables the delay function

Pulse inputs



Display → Configuration, <Module IO <x.>, Pulse input

with <x> the number of the module to which the input is physically connected

Each version 1 flow module supports 1 single or dual pulse input meant for a flow meter that provides a single or a dual pulse output signal. A version 2 flow module supports up to 4 single or dual pulse inputs.

A dual pulse signal is a set of two pulse signals ('pulse trains') A and B that originate from the same flow meter. The two pulse trains are similar but shifted in phase (typically 90°).

The primary purpose of the dual signal is to allow for **pulse integrity checking**. Added or missing pulses on either pulse train are detected and corrected for and simultaneous noise pulses are rejected.

The function provides detailed information on the raw, corrected and bad pulses for both channels and for both the forward and reverse flow direction.

The phase shifted pulse train signal also allows for automatic detection of flow direction. Each A pulse is followed by a B pulse within a time period (Δt) in case the flow runs in the forward direction. In case the flow runs in the reverse direction, the opposite is the case, i.e. each B pulse is followed by an A pulse within the same time period Δt .

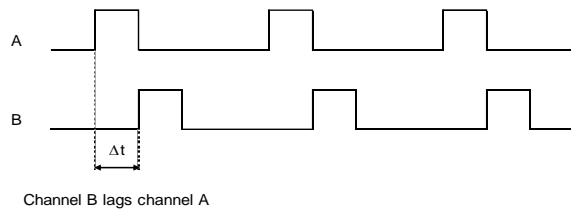

Figure 3: Flow direction from dual pulse signal

There is also the option to conditionally output the raw pulse 'prover bus' signal, which is useful in case a separate flow computer is used for proving purposes. The proving flow computer reads the 'prover bus' pulse output from the meter flow computer to perform prove measurements including double chronometry if required. The 'prover bus' output signal is generated at 10 MHz, the same frequency at which the raw pulse input signals are sampled.

The Flow/X series of flow computers provides **Level A** and **Level B** pulse security as defined in ISO 6551. Level A means that bad pulses are not only detected but also corrected for. **Level B** means that bad pulses are detected but not corrected for.



Like any digital input signal a pulse input has a threshold level (Volts) that determines whether the actual signal is considered as on or off.

The actual threshold level is defined on display 'Digital IO settings'.

The following settings are available for the pulse input of each flow module.

Pulse fidelity checking

Pulse fidelity level	1000	Pulse fidelity levels according to ISO6551 0: None No pulse fidelity checking or correction 1: Level A Pulse verification, alarming and correction 2: Level B Pulse verification and alarming; no correction If pulse fidelity level A is enabled, then the corrected pulses are used for flow totalization. If pulse fidelity level B is enabled or if pulse fidelity checking is disabled, then the uncorrected pulses of channel A are used or, in case channel A does not provide any pulses, the uncorrected pulses of channel B are used.
Fall back to secondary pulse	1000	Only applicable to pulse fidelity level B. 0: Enabled pulse B will be used when pulse A fails. 1: Disabled pulse B is solely used for pulse verification.
Error pulses limit	1000	Only applicable to dual pulse inputs. If the total number of missing, added and simultaneous pulses for either channel becomes larger than this value, the FC will generate an 'error pulses limit alarm'. The value 0 disables the error pulses limit check.
Good pulses reset limit	1000	Only applicable to dual pulse inputs. If the number of good pulses since the last 'bad' pulse has reached this value, the bad pulse count and alarms will be reset automatically. The value 0 disables this reset function.
Error rate limit	1000	Only applicable to dual pulse inputs. If the difference in frequency between the two raw pulse trains is larger than this limit within the last calculation cycle, the FC will generate an 'Error pulse rate limit alarm'. The value 0 disables the error rate limit check.
Dual pulse fidelity threshold	1000	Dual pulse fidelity checking is only enabled when the actual pulse frequency is above this threshold limit [Hz]

Prover bus pulse outputs

Prover bus pulse output A	1000	Enables prover bus output A. Meant for systems using a common prover bus to a separate prover or master meter flow computer. The flow module will output the raw pulse input signal A directly to the prover bus pulse out A channel. (This channel is assigned to a specific digital on display 'Digital IO assign') In case of a multi-stream setup with a common prover or common master meter only the meter under prove should have its prover bus output enabled. Automatically set by prover logic.
Prover bus pulse output B	1000	Enables prover bus output B. Meant for systems using a common prover bus to a separate prover or master meter flow computer. The flow module will output the raw pulse input signal B directly to the prover bus pulse out B channel. (This channel is assigned to a specific digital on display 'Digital IO assign') In case of a multi-stream setup with a common prover or common master meter only the meter under prove should have its prover bus output enabled. Automatically set by prover logic.

Time period inputs



Display → Configuration, <Module IO <x>, Time period inputs, Time period input <y>

with <x> the number of the module to which the input is physically connected and <y> the input number

Each flow module has 4 time period inputs, which can be used for densitometer and specific gravity transducer inputs. For each time period input the following settings are available.

Difference limit	1000	Maximum allowable difference in microseconds. When the time period between two consecutive pulses differs more than this limit from the previous time period, the reading is considered to be abnormal. Following an abnormal reading there must be 3 consecutive readings within the limit before the time period value is considered normal again. When no 3 consecutive readings within the limit are available in the last 5 readings then the input signal is considered to be invalid. Resolution of the limit value is 100 nanoseconds
------------------	------	--



Like any digital input signal a time period input has a threshold level (Volts) that determines whether the actual signal is considered as on or off.

The actual threshold level is defined on display 'Digital IO settings'.

Analog outputs



Display → IO, <Module <x>, Configuration, Analog outputs, Analog output <y>

with <x> the number of the module to which the output is physically connected and <y> the output number

Each flow module has 4 analog outputs. For each analog output the following settings are available.

Tag	600	Alphanumeric string representing the tag name of the output signal, e.g. "AO-045". Only used for display and reporting purposes.
Full scale	600	The value in engineering units that corresponds with the full scale (20mA) value. Uses the original FC units: [m3/hr] for volume flow rate, [tonne/hr] for mass flow rate, [°C] for temperature, [bar] for pressure, [kg/m3] for density. E.g. for a temperature with a range of -30..+80 [°C] the value 80 must be entered. For a temperature with a range of 0-300 [°F] the value 148.889 [°C] must be entered.
Zero scale	600	The value in engineering units that corresponds with the zero scale (4mA) value. Uses the original FC units: [m3/hr] for volume flow rate, [tonne/hr] for mass flow rate, [°C] for temperature, [bar] for pressure, [kg/m3] for density. E.g. for a temperature with a range of -30..+80 [°C] the value -30 must be entered. For a temperature

Dampening factor	600	with a range of 0-300 [°F] the value -16.778 [°C] must be entered. Dampening factor [0..8]. Can be used to obtain a smooth output signal. The value represents the number of calculation cycles * 8 that are required to get to the new setpoint. 0: No filtering 1: It takes 8 cycles to get to the new setpoint 2: It takes 16 cycles to get to the new setpoint etc.
------------------	-----	---

For example: the following filtering is used when setpoint is set to 1.

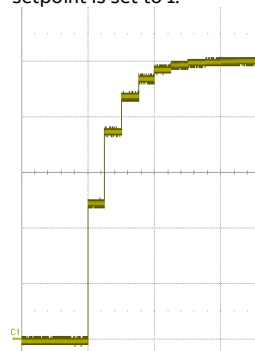

Figure 4: Analog output dampening factor

Pulse outputs

Pulse outputs can be used to feed low frequency pulses to an electro-mechanical (E/M) counter or to control a sampling system.

Pulse outputs are connected to a totalizer: A pulse is given each time that the totalizer has incremented by a certain value.

A reservoir is used to accumulate the pulses. Pulses are taken from the reservoir and fed to the output at a rate that will not exceed the specified maximum output rate



Display → IO, Configuration, <Module <x>, Pulse outputs, Pulse output <y>

with <x> the number of the module to which the output is physically connected and <y> the output number

Each flow module has 4 pulse outputs. For each pulse output the following settings are available.

Max. frequency	600	Maximum pulse frequency. When output pulses are generated at a frequency higher than the maximum output rate, the superfluous pulses will be accumulated in the pulse reservoir. The maximum output rate is not a restriction of the Flow-X flow computer, but may be a restriction of the connected device. E.g. a electro-mechanical counter may be able to generate pulses up to 10 Hz.
Pulse duration	600	The flow computer uses a fixed pulse duration to output the pulses. The 'Pulse duration' is the time in milliseconds that an output pulse remains active (high). The actual pulse duration that will be used is the minimum of this setting and the time corresponding to 50% duty cycle at maximum frequency

		E.g. if the pulse duration setting = 0.25 sec and the maximum frequency = 5 Hz, then the actual pulse duration equals $0.5 * 1/5 = 0.1$ sec.
Reservoir limit	600	Alarm limit for the number of pulses in the reservoir buffer. When the number of pulses in the reservoir exceeds the limit, then an alarm will be raised and no further pulses will be accumulated.



Display → IO, Force IO

If an input is forced the flow computer will generate an alarm.

Frequency outputs

Frequency outputs can be used to feed high frequency pulses to an electro-mechanical (E/M) counter or to control a sampling system.

Frequency outputs are connected to a process variable: The actual value of the process variable is translated into a pulse frequency using linear interpolation. In principle any process value may be used (temperature, pressure, etc.), but flow rate and density are most common.



The use of frequency outputs is only supported by FPGA version 1422-21-2-2012 or later.



Display → IO, <Module <x>, Configuration, Frequency outputs, Frequency output <y>

with <x> the number of the module to which the output is physically connected and <y> the output number

Each flow module has 4 frequency outputs. For each frequency output the following settings are available.

Full scale value	600	The value in engineering units that corresponds to the highest frequency. Uses the original FC units: [m3/hr] for volume flow rate, [tonne/hr] for mass flow rate. E.g. for a flow rate with a range of 0-2000 [m3/hr] the value 2000 must be entered. For a flow rate with a range of 0-1000 [l/min] the value 60 [m3/hr] must be entered.
Zero scale value	600	The value in engineering units that corresponds with the lowest frequency. Uses the original FC units: [m3/hr] for volume flow rate, [tonne/hr] for mass flow rate.
Full scale frequency	600	Highest frequency
Zero scale frequency	600	Lowest frequency (>=0)

Forcing I/O

For testing purposes all inputs and outputs can be forced to a defined value or state. This option is available at security level 1000 'engineer' or higher.

Overall setup

The overall settings are related to the flow computer device itself and to settings that are common for all meter runs.

Flow computer concepts

The Flow-X supports 3 different flow computer concepts:

- 1 Independent flow computer
- 2 Station / prover flow computer with remote run flow computers
- 3 Single-stream flow computer(s) with remote prover IO server

Independent flow computer

The flow computer does its job independent of other flow computers. It might be a single or multi-stream flow computer. If needed, station and / or proving functionality can be enabled, which is done by the flow computer itself. No other flow computer is needed for that. The flow computer runs one application, which takes care of everything.

Depending on the required functionality the flow computer has to be configured as one of the following FC types:

- 1: Run only
- 2: Station / run
- 3: Proving / run
- 4: Station / proving / run

Station / prover flow computer with remote run flow computers

In this concept a number of flow computers are working together. Usually several single-stream flow computers are involved. Station and / or proving functionality is done by a separate flow computer, which is communicating to the (remote) run flow computers to exchange the data that's needed to fulfill its station / proving tasks. Any meter can be proved from the station / prover flow computer. The station / proving flow computer and run flow computers are each running a separate application.

The run flow computers have to be configured as FC type:

- 1: Run only

Depending on the required functionality the station / proving flow computer has to be configured as one of the following FC types:

- 6: Station only
- 7: Proving only
- 8: Station / proving

On the remote run flow computer(s) the '**Connect to remote station**' Modbus driver has to be enabled (in Flow-Xpress 'Ports and Devices').

It's also possible to enable run functionality on the station / proving flow computer, f.e. in case of master meter proving, where the proving flow computer can also control the master meter. In that case the station / proving flow computer has to be configured as one of the following FC types:

- 2: Station / run
- 3: Proving / run
- 4: Station / proving / run

The maximum number of runs in a station (local plus remote runs) is 8.



In case of a station that consists of a **local** run (controlled by the station flow computer itself) and a number of **remote** runs (remote run flow computers running their own application), the local run is numbered 1 and the remote runs can be configured as runs 2 - 8.

Single-stream flow computer(s) with a remote prover IO server

In this concept a number of single stream flow computers are involved. Each of them contains proving functionality to prove its own meter. However, the run flow computers are not communicating directly to the prover, but through a separate flow computer, which has been configured as remote IO server. A prove is initiated on the run flow computer. The run flow computers and the remote prover IO server flow computer are each running a separate application.

The run flow computers have to be configured as FC type:

- 3: Proving / run

The remote prover IO server has to be configured as FC type:

- 9: Prover IO server only

It's also possible to enable meter run functionality on the prover IO server as well. This can be done by configuring it as:

- 3: Proving / run

In this case the prover IO can be used locally (for proving the run of the prover IO server FC itself), or remotely (for proving the other runs).



In order to be able to communicate to the 'remote run' flow computer(s), the station / proving flow computer must have a '**Connect to remote run**' Modbus driver configured for every individual remote run flow computer (in Flow-Xpress 'Ports and Devices').



In order to be able to communicate to the remote 'prover IO module' the run flow computers must have the '**Connect to remote prover IO server**' driver configured in Flow-Xpress 'Ports and Devices'.

On the remote prover IO server FC the 'Act as remote prover IO server' driver has to be enabled in Flow-Xpress 'Ports and Devices'

Common settings



Display → Configuration, Overall setup, Common settings

Flow computer type	1000	<p>Determines whether the flow computer contains meter run functionality and / or station functionality and / or proving functionality.</p> <p>1: Run only Only meter run functionality is activated on this flow computer. Station functionality and proving logic are de-activated. The flow computer is either a single run FC or a multiple run FC. In case of a single run FC the run may be part of a remote station.</p> <p>2: Station / run Both meter run and station functionality are activated on this flow computer. Proving logic is de-activated. The flow computer is a station FC with one or more local runs and may optionally be communicating to one or more remote runs FC's. All local and remote runs are part of the station.</p> <p>3: Proving / run Both meter run functionality and proving logic are activated on this flow computer. Station functionality is de-activated. The flow computer is a prover FC with one or more local runs and may optionally be communicating to one or more remote run FC's. All local and remote runs are independent and are not part of a station, but they can all be proved by this FC.</p> <p>4: Station / proving / run Meter run and station functionality and proving logic are all activated on this flow computer. The flow computer is a station / prover FC with one or more local runs and may optionally be communicating to one or more remote runs FC's. All local and remote runs are part of the station and can be proved by this FC.</p> <p>6: Station only Only station functionality is activated on this flow computer. Run functionality and proving logic are de-activated. The flow computer is a station FC without local runs and is communicating to one or more remote run FC's. All remote runs are part of the station.</p> <p>7: Proving only Only proving logic is activated on this flow computer. Run and station functionality are de-activated. The flow computer is a prover FC without local runs and is communicating to one or more remote run FC's which can be proved by it.</p> <p>8: Station / proving Station functionality and proving logic are activated on this flow computer. Run functionality is disabled. The flow computer is a station / prover FC without local runs and is communicating to one or more remote runs FC's. All remote runs are part of the station and can be proved by this FC.</p> <p>9: Prover IO server only The flow computer acts as an IO server to one or more prover FC's. Run and station functionality are de-activated. Prover logic is deactivated, but the prover IO (prover temperature, prover pressure, prover density, 4-way valve commands and status, prove start command, piston upstream status (Brooks), plenum pressure charge and vent commands (Brooks), low N2 status (Brooks)) are available.</p>
Common product	1000	<p>Defines whether a common product setup is used for all meter runs or each meter run uses its own product setup.</p>

and batching		<p>Determines also whether a common batch is used for all runs, or each run uses its own batch.</p> <p>0: Disabled Each meter run uses a separate product setup. Each meter run runs a separate batch, which can be started and stopped independently.</p> <p>1: Enabled A common product setup is used for all meter runs. All runs are running one common batch, which is started / stopped synchronously.</p> <p>In case of a station FC with one or more remote run flow computers, Common product and batching has to be enabled both on the station FC and on the remote run flow computer(s).</p> <p>In case of a proving flow computer without station functionality (FC type proving/run or proving only), Common product and batching has to be disabled both on the proving FC and on the remote run flow computer(s).</p>
Common density input	1000	<p>Defines whether one common (station) density input (e.g. densitometer) is used for all meter runs or separate density inputs for each individual meter run.</p> <p>0: Disabled Separate density inputs for each individual run</p> <p>1: Enabled One common density input for all runs</p> <p>In case of a station FC with one or more remote run flow computers which share a common density input, Common density input has to be enabled both on the station flow computer and on the remote run flow computer(s).</p> <p>In case of a station FC with one or more remote run flow computers with separate density inputs, Common density input has to be disabled both on the station flow computer and on the remote run flow computer(s).</p>
Common BS&W input	1000	<p>Defines whether one common (station) BS&W input is used for all meter runs or separate BS&W inputs for each individual meter run.</p> <p>0: Disabled Separate BS&W inputs for each individual run</p> <p>1: Enabled One common BS&W input for all runs</p> <p>In case of a station FC with one or more remote run flow computers which share a common BS&W input, Common BS&W input has to be enabled both on the station flow computer and on the remote run flow computer(s).</p> <p>In case of a station FC with one or more remote run flow computers with separate BS&W inputs, Common BS&W input has to be disabled both on the station flow computer and on the remote run flow computer(s).</p>
Common viscosity input	1000	<p>Defines whether one common (station) viscosity input is used for all meter runs or separate viscosity inputs for each individual meter run.</p> <p>0: Disabled Separate viscosity inputs for each individual run</p> <p>1: Enabled One common viscosity input for all runs</p> <p>In case of a station FC with one or more remote run flow computers which share a common viscosity input, Common viscosity input has to be enabled both on the station flow computer and on the remote run flow computer(s).</p> <p>In case of a station FC with one or more remote run flow computers with separate viscosity inputs, Common viscosity input has to be disabled both on the station flow computer and on the remote run flow computer(s).</p>
Number of products	1000	<p>Defines the number of separate products that are defined on the FC (max. 16).</p>

Constants

Atmospheric pressure	1000	<p>The local atmospheric pressure [bar(a)] is used to convert gauge pressure to absolute pressure and vice versa.</p>
Base pressure	1000	<p>Base pressure [bar(a)], which is used for calculation of CPL according to API MPMS 12.2.2. Formula:</p>

		$CPL = 1/(1-F*(\text{observed pressure} - (\text{equilibrium pressure} - \text{base pressure})))$
Density of water	1000	The density of water at reference conditions [kg/sm ³] is used to convert relative density to density and vice versa.
Viscosity reference temperature	1000	Reference temperature for base viscosity calculation.

Totalizer settings

Volume total rollover value	1000	The rollover value for the indicated, gross, gross standard and net standard volume cumulative totals.
Mass total rollover value	1000	The rollover value for the mass cumulative totals.
Mass totals type	1000	Determines whether the calculated mass totals and mass flow rates reflect the 'mass in vacuum' or 'mass in air'. 1: Mass in vacuum Mass totals and flow rates reflect the 'mass in vacuum', which is calculated using the standard density 2: Mass in air Mass totals and flow rates reflect the 'mass in air', which is calculated using the standard density in air. Standard density in air is calculated according to API MPMS 11.5.3, using the formula: $SD_{air} = 1.000149926 * SD_{vacuum} - 1.199407795$ In case of a mass flow meter the measured mass flow (in vacuum) is converted into 'mass in air' by multiplying the mass by SD_{air} / SD_{vacuum} .
Reverse totals	1000	Enables / disabled the reverse totals 0: Disabled 1: Enabled If enabled, the flow computer maintains forward AND reverse totalizers and averages. If disabled, the flow computer only maintains one set of (forward) totalizers and averages. Based on the flow direction input the forward or reverse totalizers are active. See paragraph 'Flow direction input' for an explanation how to configure the flow direction.
Disable totals if meter is inactive	1000	Controls if the totals are disabled when the meter is inactive (flow rate, dP or pulse frequency below the low flow cutoff). 0: No 1: Yes
Set flowrate to 0 if meter is inactive	1000	Controls if the flow rates are set to 0 if the meter is inactive (flow rate, dP or pulse frequency below the low flow cutoff). 0: No 1: Yes
Reset maint. totals on entering maint. mode	1000	This setting controls whether the maintenance totalizers start at 0 when entering maintenance mode or at the values from the last time that maintenance mode has been active. 0: No 1: Yes

Alarm settings

Disable alarms if meter is inactive	1000	Controls if the limit alarms, calculation alarms and deviation alarms are suppressed when the meter is inactive (flow rate, dP or pulse frequency below the low flow cutoff). 0: No 1: Yes
Disable alarms in maintenance mode	1000	Controls if the limit alarms, calculation alarms and deviation alarms are suppressed when the meter is set in maintenance mode. 0: No 1: Yes
Deviation alarm delay	1000	Delay time [s] on deviation alarms: <ul style="list-style-type: none"> Pressure deviation alarms (deviation between both pressure transmitter readings in case of dual transmitters)

- Temperature deviation alarms (deviation between both temperature transmitter readings in case of dual transmitters)
- Density deviation alarms (deviation between two densitometers)
- Flow deviation alarms (deviation between pulse flow rate and smart meter flow rate)
- dP deviation alarms (deviation between two dP transmitter values if two transmitters of the same range are used)

Batch settings

Batch quantity type	1000	Defines whether the batch quantities represent volume [m ³] or mass [tonne]. 1: Volume 2: Mass
Allow batch end if meter is active	1000	Controls whether it is allowed to end a batch when the meter is active (flow rate, dP or pulse frequency above the low flow cutoff). 0: No 1: Yes Note: this option avoids running batches to be ended before the flow has stopped
Allow batch end if total 0	1000	Controls whether it is allowed to end a batch when the current batch total is 0, so when there has been no flow since the previous batch end. 0: No 1: Yes Note: this option avoids 'empty' meter tickets to be generated.
Shift batch stack on batch end	1000	Controls whether the batch stack is shifted upwards when a batch end command is given. 0: Disabled 1: Enabled Disabling this option means that only the first batch of the batch stack is used.
Batch start command	1000	Defines whether batches are started manually by giving a start command, or automatically as soon as a flow is detected. 0: Disabled 1: Enabled If enabled, after a batch end command the batch totals are inactive until a batch start command is given. If disabled, the batch totals remain active after a batch end and the batch start command is not used.
All totals inactive after batch end	1000	Only applicable if the batch start command is enabled. Defines the behavior of the totalizers between a batch end command and the next batch start command. 0: No Only the batch totals are inactive after a batch end, while the cumulative and period totals remain active. 1: Yes All cumulative, period and batch totals are inactive after a batch end.
Station batch recalculation	1000	Defines if batch recalculation data is to be entered for the whole station at once (on one display), or for each run separately (separate displays for each run). 0: Disabled 1: Enabled In case of a station FC with one or more remote run flow, Station batch recalculation has to be enabled / disabled both on the station flow computer and on the remote run flow computer(s).

Loading

Loading functionality	1000	Controls whether loading functionality is enabled or not 0: Disabled 1: Enabled Optional loading functionality can be added to the flow computer, such as: loading data entry, loading curve (low / high low flow rate), pump control, loading permissives, digital or 2-stage control valves.
-----------------------	------	---

Metrological

MID compliance	1000	Determines if compliance with the measuring instruments directive (MID, the european metrology law) is required or not. Enables the accountable / non-accountable totalizers and alarms. 0: Disabled 1: Enabled If enabled, the accountable totalizers are active only if there's no accountable alarm, while the non-accountable totalizers are active if there is an accountable alarm. If disabled, both the accountable and non-accountable totalizers are inactive. Refer to chapter 'MID Compliance' for more information. If enabled then metrological data is shown on display 'Metrological'.
Allow manual overrides	1000	Determines whether manual (operator) transmitter overrides are accepted or not. 0: No 1: Yes

Date and time

Date format	1000	Date format used on the flow computer screens and reports 1: dd/mm/yy 2: mm/dd/yy
Time set inhibit time	1000	Number of seconds around the hour shift that any time shift request is inhibited. This is to avoid problems with the closing of period totals and the generation of reports on the hour / day shift. Typically 30 sec.
SNTP time Synchronization	1000	Switches on or off SNTP time Synchronization. If enabled, the flow computer will communicate to one or more NTP time servers (local or remote) in order to retrieve the actual date and time. 1: Enabled 0: Disabled

Historical data archives

Generate batch / loading archive data	1000	Defines if batch or loading archive data is generated and stored after each batch / loading end. 0: No 1: yes Please be aware that the actual historical data archive content has to be configured in Flow-Xpress prior to writing the application to the flow computer.
Generate hourly archive data	1000	Defines if hourly archive data is generated and stored after each hour end. 0: No 1: yes Please be aware that the actual historical data archive content has to be configured in Flow-Xpress prior to writing the application to the flow computer.
Generate daily archive data	1000	Defines if daily archive data is generated and stored after each day end. 0: No 1: yes Please be aware that the actual historical data archive content has to be configured in Flow-Xpress prior to writing the application to the flow computer.
Generate period A archive data	1000	Defines if period A archive data is generated and stored after each period A end. 0: No 1: yes Please be aware that the actual historical data archive content has to be configured in Flow-Xpress prior to writing the application to the flow computer.
Generate period B archive data	1000	Defines if period B archive data is generated and stored after each period B end. 0: No 1: yes Please be aware that the actual historical data archive content has to be configured in Flow-Xpress prior to writing the application to the flow computer.

Generate prove archive data	1000	Defines if prove archive data is generated and stored when a prove is finished. 0: No 1: yes Please be aware that the actual historical data archive content has to be configured in Flow-Xpress prior to writing the application to the flow computer.
-----------------------------	------	--

System

Memory low alarm limit	1000	A memory low alarm will be given if the available memory of any module gets below this limit [KB].
------------------------	------	--

FC running DO

FC running status DO	1000	Defines if the flow computer running status is sent to a digital output. If configured, this output will always be high as long as the flow computer is running. 0: Disabled 1: Enabled
----------------------	------	---

FC running status DO module	1000	Number of the flow module to which the output signal is physically connected.
-----------------------------	------	---

FC running status DO channel	1000	Number of the digital channel on the selected module to which the output signal is physically connected.
------------------------------	------	--

FC redundancy DO

FC duty status DO	1000	Defines if the flow computer duty status is sent to a digital output. 0: Disabled 1: Enabled Only applicable if flow computer redundancy is enabled. Please be aware that redundancy has to be enabled / configured in Flow-Xpress prior to writing the application to the flow computer.
-------------------	------	--

FC duty status DO module	1000	Number of the flow module to which the output signal is physically connected.
--------------------------	------	---

FC duty status DO channel	1000	Number of the digital channel on the selected module to which the output signal is physically connected.
---------------------------	------	--

Meter ticket



Display → Configuration, Overall setup, meter ticket

Calculation settings

API 12.2.2 Measurement tickets compliance	1000	Determines whether meter tickets should comply with the rounding, discrimination and calculation rules as per API MPMS 12.2.2. This standard requires a recalculation on the average input data at the end of the batch. Therefore the 'recalculated meter ticket' is generated and normal meter tickets are disabled. 0: Disabled 1: Enabled
Implement meter factor retroactively	1000	Applies the meter factor value as it is at the end of the batch to the whole batch. This means that a new meter factor from a prove during a running batch is applied from the beginning to the end of that batch. Enabling 'implement meter factor retroactively' also creates the possibility to manually enter an override value before ending the batch. 0: Disabled 1: Enabled

		<p>If enabled, an automatic batch recalculation will be done at the end of the batch, using the new meter factor for the whole batch. Results are shown on the 'recalculated meter ticket'. Normal meter tickets are disabled</p> <p>If disabled, the new meter factor from a prove during a batch is only applied to the part of the batch after the implementation of the new meter factor.</p>
Implement standard density retroactively	1000	<p>Enabling 'Implement standard density retroactively' creates the possibility to manually enter an override standard density value before ending the batch.</p> <p>0: Disabled 1: Enabled</p> <p>If enabled, an automatic batch recalculation will be done at the end of the batch, using the override standard density value, if entered, for the whole batch. If no override value is entered, the batch average standard density value is used. Results are shown on the 'recalculated meter ticket'. Normal meter tickets are disabled</p>
Implement BS&W retroactively		<p>Enabling 'Implement BS&W retroactively' creates the possibility to manually enter an override BS&W value before ending the batch.</p> <p>0: Disabled 1: Enabled</p> <p>If enabled, an automatic batch recalculation will be done at the end of the batch, using the override BS&W value, if entered, for the whole batch. If no override value is entered, the batch average BS&W value is used. Results are shown on the 'recalculated meter ticket'. Normal meter tickets are disabled</p>
API rounding	1000	<p>Determines whether the rounding and truncating rules of the applicable API standard(s) are applied or not.</p> <p>0: Disabled The calculation of the standard density, CTL, CPL and CTPL is performed with full precision.</p> <p>1: Enabled The calculation of the standard density, CTL, CPL and CTPL is performed in accordance with the selected API standard, including all rounding and truncating rules.</p>
Correction factors use last good	1000	<p>Determines whether or not the last good calculated values of CTL, CPL and CTPL are used in case of a calculation failure.</p> <p>0: No The CTL, CPL and CTPL factors are set to 1 if the calculation fails or is out of range</p> <p>1: Yes The CTL, CPL and CTPL factors are set to the last good calculated values if the calculation fails or is out of range</p>
Calculation extrapolation allowed	1000	<p>Determines whether or not the process conditions are allowed to go beyond the boundaries of the applicable API standard.</p> <p>0: No The calculation fails when conditions get out of the range of the API standard</p> <p>1: Yes The calculation is continued when conditions get out of the range of the API standard</p>
Calculation out of range alarms	1000	<p>Defines whether or not an alarm is given if a process value gets out of range of the applicable API standard.</p> <p>Enables / disables the following alarms: Standard density calc out of range alarm Meter density calc out of range alarm</p> <p>0: Disabled 1: Enabled</p>
Averaging method	1000	<p>Determines the method used for calculating the batch and period averages.</p> <p>0: Time weighted 1: Flow weighted on gross volume 2: Flow weighted on mass 3: Flow weighted on gross standard volume</p>

		In either case averaging is inactive if the meter is inactive (flow rate, dP or pulse frequency below the low flow cutoff).
Water / steam switch pressure deadband	1000	<p>Only applicable to product 'Water / Steam'.</p> <p>Switches from water to steam if meter pressure < equilibrium pressure - deadband. Switches from steam to water if meter pressure > equilibrium pressure + deadband.</p>

Decimal resolution

Volume total decimal places	1000	<p>Decimal resolution at which the volume cumulative, batch and period totals are maintained.</p> <p>Set to 3 decimal places if API 12.2.2 Measurement tickets compliance is enabled.</p>
Mass total decimal places	1000	<p>Decimal resolution at which the mass cumulative, batch and period totals are maintained.</p>
CTL decimal places	1000	<p>Number of decimals to which the CTL values on batch and period reports are rounded.</p> <p>Set to 4 decimal places if API 12.2.2 Measurement tickets compliance is enabled.</p> <p>Note that when API rounding is enabled, the CTL factor is already rounded to the number of decimal places required by the applicable API standard.</p>
CPL decimal places	1000	<p>Number of decimals to which the CPL values on batch and period reports are rounded.</p> <p>Set to 4 decimal places if API 12.2.2 Measurement tickets compliance is enabled.</p> <p>Note that when API rounding is enabled, the CTL factor is already rounded to the number of decimal places required by the applicable API standard.</p>
CTPL decimal places	1000	<p>Number of decimals to which the combined correction factors CCF (CTPL) on batch and period reports are rounded.</p> <p>Set to 4 decimal places if API 12.2.2 Measurement tickets compliance is enabled.</p>

Period settings

The application provides custody transfer data (totals and averages) for 4 different periods, the hourly period, the daily period and 2 freely definable periods A and B.

The start of the daily period is configurable. Periods A and B can be used for any period type and any period start, e.g. a 2 weekly period starting at Tuesday 06:00 or a 2nd fiscal daily period starting at 08:00. The flow computer maintains similar totals and averages for the hourly, daily, period A and period B periods.



Display → Configuration, Overall setup, Periods

Daily period

Day start hour	600	Start of the daily period as offset in hours from midnight. E.g. for a day start at 6:00 AM this parameter should be set to 6.
Day start offset minutes	600	Day offset from the whole hour in number of minutes
Day start offset seconds	600	Day offset from the whole hour in number of seconds

Periods A / B

Period <X> label	600	Text to be shown on period displays and reports E.g. "Two weekly" or "Monthly"
Period <X> type	600	Type of period 2: Minute

		3: Hour
		4: Day
		5: week
		6: Month
		7: Quarter
		8: Year
Period <x> duration	600	Period duration, i.e. number of period types. E.g. for a 2 weekly period, enter 2 (and set the period type at 5: week).
Period <x> offset days	600	Period offset from start of year ('January 1.') expressed in number of days, e.g. 10 means 'January 11.'
Period <x> offset hours	600	Period offset from midnight in number of hours. e.g. 6 means 6:AM
Period <x> offset minutes	600	Period offset from the whole hour in number of minutes, e.g. 30 means 30 minutes after the hour
Period <x> offset seconds	600	Period offset from the whole hour in number of seconds

Period end commands

Manual commands to end the periods for testing and special applications. The commands close the applicable period totals and averages and generate the period reports and archives (if applicable).

End hourly period	1000	Manual command to close the hourly period
End daily period	1000	Manual command to close the daily period
End period A	1000	Manual command to close the period A period
End period B	1000	Manual command to close the period B period

Display levels

When no user has logged in to the flow computer, only abbreviated versions of the following displays are shown:

- In-use values
- Flow rates
- Cumulative totals

All other displays have a minimum security level that needs to be activated (by a log-in) before the displays are shown and therefore accessible.

The following settings define the minimum security level required to access the associated displays. A display is hidden when the active security level is below the setting.

For each type of displays a selection can be made from the following list:

Always show

Always shows the display(s), even if not logged in

Operator (500)

Only show the display(s) if logged in at security level 'operator' or higher

Technician (750)

Only show the display(s) if logged in at security level 'technician' or higher

Engineer (1000)

Only show the display(s) if logged in at security level 'engineer' or higher

Administrator (2000)

Only show the display(s) if logged in at security level 'administrator'

The display levels only define the security levels needed for **viewing** specific types of displays. They don't define the security levels needed for **modifying** the parameters that are shown on the displays. Each parameter has its own minimum security level, which is needed to modify it, as is indicated in this manual.



Display → Configuration, Overall setup, Display levels

Detailed data display level	2000	Minimum security level for all displays that contain detailed information: <ul style="list-style-type: none"> • Live data • Flow rates • Cumulative totals • Flow meter details • Temperature details • Pressure details • Density details • BS&W details • Viscosity details • Period data • Historical data • Event log • Metrological details (if applicable) • IO diagnostics • Communication diagnostics
Product display level	2000	Minimum security level for defining the 16 products
Proving display level	2000	Minimum security level for the proving displays
Batch control display level	2000	Minimum security level for batch control displays
Batch stack display level	2000	Minimum security level for the batch stack display
Loading display level	2000	Minimum security level for the loading displays
Sampler control display level	2000	Minimum security level for sampler control displays
Batch recalculation display level	2000	Minimum security level for the batch recalculation display
Valve control display level	2000	Minimum security level for displays for controlling the motor-operated valves
Flow control display level	2000	Minimum security level for flow control displays
Reports display level	2000	Minimum security level for viewing and printing reports
Alarm overview display level	2000	Minimum security level for accessing the alarm overview display
IO calibration display level	2000	Minimum security level for accessing the displays to calibrate the analog IO
Metrological configuration display level	2000	Minimum security level for accessing the metrological configuration displays (like run set, flow meter, pressure, temperature, pressure and density configuration displays)
Non-metrological configuration display level	2000	Minimum security level for accessing the non-metrological configuration displays (like valve control, flow control, analog outputs, pulse outputs)

Customer definition

Up to 16 customers can be defined. To each batch a customer number can be assigned. The following settings define the customer names for reporting purposes.



Display → Configuration, Overall setup, Customer definition

Customer <x> name	600	Name of customer <x>
-------------------	-----	----------------------

case of a single stream flow computer, the meter run, e.g. "Green field, South section"

SNTP time Synchronization



Display → Configuration, Overall setup, SNTP Time Synchronization

SNTP period duration (days)	1000	Use this setting to specify how often the flow computer will contact all configured NTP servers for time synchronization. The minimum time between two consecutive requests is 1 day.
SNTP time of day (hh:mm)	1000	Time of day for time synchronization, to be entered as 'hh:mm'. A request to the configured NTP server(s) will be sent 30 seconds later, at hh:mm:30.
NTP server 1/4 - hostname / IP-address	1000	Up to 4 NTP servers can be configured. Servers can be identified by their hostname or IP-address. In case of hostnames, a valid name server (DNS server) has to be configured on display System->Network
NTP server 1/4 - port number	1000	Port number of the NTP server (default 123)
Time zone relative to UTC	1000	Time shift due to time zone relative to UTC. F.e. for 'UTC - 6:00' enter '-6'; for 'UTC + 1:00' enter '1'.
Number of samples	1000	Number of samples to be collected from the NTP server(s)
Number of attempts	1000	Number of connection attempts in case of an error.
Minimum time shift	1000	A timeshift will only be applied if the timeshift that is returned from the NTP sever is larger than this minimum value (seconds). This avoids frequent spurious time shifts.
Maximum time shift	1000	A timeshift will only be applied if the timeshift that is returned from the NTP sever is smaller than this maximum value (seconds).
SNTP test command	1000	This command enables testing of the SNTP logic of the flow computer and the NTP servers that have been configured. Upon launching the flow computer sends one NTP request to all configured NTP servers.

System data



Display → Configuration, Overall setup, System data

Flow computer tag	600	Tag name of the flow computer, e.g. "FY-1001A"
System tag	600	Tag name for the meter station or in case of a single stream flow computer, the meter run, e.g. "YY-100"
System description	600	Description of the meter station or in case of a single stream flow computer, the meter run, e.g. "Export stream 2"
System company	600	Name of the company that owns the meter station or in case of a single stream flow computer, the meter run, e.g. "LiqTransco"
System location	600	Name of the location of the meter station or in

Product definition

Up to 16 products can be defined. The actual number of products to be used in the application can be configured on display: Overall setup, Common settings.

If 'common product and batching' is enabled, the whole station is using one and the same product. If multiple products have been defined, the in-use product can be selected by the operator on the Product display, Batch control display or Batch stack display.

If 'common product and batching' is not enabled, a separate product can be used for each run. The product can be fixed per run (configurable on the Run setup display) or selected by the operator on the Product display, Batch control display or Batch stack display.



Display → Configuration, Products, Product <x>

With <x> the product number

For each product the following configuration parameters are available:

Name	1000	Name of the product
Density conversion method	1000	Method to convert the density between densitometer conditions, standard conditions and meter conditions. 1: 53/54A: 1980 Crude API-2540 table 53A/54A: Crude oil at 15°C. 2: 53/54B: 1980 Auto API-2540 table 53B/54B: Refined products at 15°C. Automatically determines the table B product range 3: 53/54B: 1980 Gasoline API-2540 table 53B/54B: Gasoline at 15°C 4: 53/54B: 1980 Transition API-2540 table 53B/54B: Transition area at 15°C 5: 53/54B: 1980 Jet fuel API-2540 table 53B/54B: Jet fuel at 15°C 6: 53/54B: 1980 Fuel oil API-2540 table 53B/54B: Fuel oil at 15°C 7: 53/54D: 1980 Lub oil API-2540 table 53D/54D: Lubricating oil at 15°C 8: 53/54A: 2007 Crude API MPMS 11.1:2007 table 53A/54A: Crude oil at 15°C. 9: 53/54B: 2007 Auto API MPMS 11.1:2007 table 53B/54B: Refined products at 15°C. Automatically determines the table B product range 10: 53/54B: 2007 Gasoline API MPMS 11.1:2007 table 53B/54B: Gasoline at 15°C 11: 53/54B: 2007 Transition API MPMS 11.1:2007 table 53B/54B: Transition area at 15°C 12: 53/54B: 2007 Jet fuel API MPMS 11.1:2007 table 53B/54B: Jet fuel at 15°C 13: 53/54B: 2007 Fuel oil API MPMS 11.1:2007 table 53B/54B: Fuel oil at 15°C 14: 53/54D: 2007 Lub oil API MPMS 11.1:2007 table 53D/54D: Lubricating oil at 15°C 15: 59/60A: 2007 Crude API MPMS 11.1:2007 table 53A/54A: Crude oil at 20°C. 16: 59/60B: 2007 Auto API MPMS 11.1:2007 table 53B/54B: Refined products at 20°C.

Automatically determines the table B product range 17: 59/60B: 2007 Gasoline API MPMS 11.1:2007 table 53B/54B: Gasoline at 20°C 18: 59/60B: 2007 Transition API MPMS 11.1:2007 table 53B/54B: Transition area at 20°C 19: 59/60B: 2007 Jet fuel API MPMS 11.1:2007 table 53B/54B: Jet fuel at 20°C 20: 59/60B: 2007 Fuel oil API MPMS 11.1:2007 table 53B/54B: Fuel oil at 20°C 21: 59/60D: 2007 Lub oil API MPMS 11.1:2007 table 53D/54D: Lubricating oil at 20°C 22: 53/54E:2007 NGL/LPG API MPMS 11.2.4 (GPA TP-27) table 53E/54E: NGL/LPG at 15°C 23: 59/60E:2007 NGL/LPG API MPMS 11.2.4 (GPA TP-27) table 59E/60E: NGL/LPG at 20°C 24: 53/54: 1952 In compliance with Tables 53 and 54 of ASTM-IP Petroleum Measurement Tables - Metric Edition - 1952 25: 5/6A: 1980 Crude API-2540 table 5A/6A: Crude oil at 60 °F. 26: 5/6B: 1980 Auto API-2540 table 5B/6B: Refined products at 60 °F. Automatically determines the table B product range 27: 5/6B: 1980 Gasoline API-2540 table 5B/6B: Gasoline at 60 °F 28: 5/6B: 1980 Transition API-2540 table 5B/6B: Transition area at 60 °F 29: 5/6B: 1980 Jet fuel API-2540 table 5B/6B: Jet fuel at 60 °F 30: 5/6B: 1980 Fuel oil API-2540 table 5B/6B: Fuel oil at 60 °F 31: 5/6D: 1982 Lub oil API-2540 table 5D/54D: Lubricating oil at 60 °F 32: 23/24A: 1980 Crude API-2540 table 23A/24A: Crude oil at 60 °F. 33: 23/24B: 1980 Auto API-2540 table 23B/24B: Refined products at 60 °F. Automatically determines the table B product range 34: 23/24B: 1980 Gasoline API-2540 table 23B/24B: Gasoline at 60 °F 35: 23/24B: 1980 Transition API-2540 table 23B/24B: Transition area at 60 °F 36: 23/24B: 1980 Jet fuel API-2540 table 23B/24B: Jet fuel at 60 °F 37: 23/24B: 1980 Fuel oil API -2540 table 23B/24B: Fuel oil at 60 °F 38: 23/24D: 1980 Lub oil API-2540 table 23D/24D: Lubricating oil at 60 °F 39: 5/6A: 2007 Crude API 11.1:2007 table 5A/6A: Crude oil at 60 °F. 40: 5/6B: 2007 Auto API 11.1:2007 table 5B/6B: Refined products at 60 °F. Automatically determines the table B product range 41: 5/6B: 2007 Gasoline API 11.1:2007 table 5B/6B: Gasoline at 60 °F 42: 5/6B: 2007 Transition API 11.1:2007 table 5B/6B: Transition area at 60 °F 43: 5/6B: 2007 Jet fuel API 11.1:2007 table 5B/6B: Jet fuel at 60 °F 44: 5/6B: 2007 Fuel oil API 11.1:2007 table 5B/6B: Fuel oil at 60 °F 45: 5/6D: 2007 Lub oil API 11.1:2007 table 5D/54D: Lubricating oil at 60 °F 46: 23/24A: 2007 Crude API 11.1:2007 table 23A/24A: Crude oil at 60 °F 47: 23/24B: 2007 Auto API 11.1:2007 table 23B/24B: Refined products at 60 °F. Automatically determines the table B product range 48: 23/24B: 2007 Gasoline API 11.1:2007 table 23B/24B: Gasoline at 60 °F

49: 23/24B: 2007 Transition API 11.1:2007 table 23B/24B: Transition area at 60 °F
50: 23/24B: 2007 Jet fuel API 11.1:2007 table 23B/24B: Jet fuel at 60 °F
51: 23/24B: 2007 Fuel oil API 11.1:2007 table 23B/24B: Fuel oil at 60 °F
52: 23/24D: 2007 Lub oil API 11.1:2007 table 23D/24D: Lubricating oil at 60 °F
53: 23/24E: 2007 NGL/LPG API MPMS 11.2.4 (GPA TP-27) NGL/LPG at 60 °F. Fully complies with GPA TP-25.
54: 5/6: 1952 In compliance with Tables 5 and 6 of ASTM-IP Petroleum Measurement Tables - American Edition - 1952
55: 23/24: 1952 In compliance with Tables 23 and 24 of ASTM-IP Petroleum Measurement Tables - American Edition - 1952
56: IAPWS-IF97 Water In compliance with IAPWS-IF97, revised release, 2007 Uses P and T to define density and phase. Totals are only enabled in liquid phase. Totals are disabled and alarm 'Gas phase detected' is active if the combination of P and T indicates steam.
57: IAPWS-IF97 Super heated steam In compliance with IAPWS-IF97, revised release, 2007 Uses P and T to define density and phase. Totals are only enabled in gas phase. Totals are disabled and alarm 'Liquid phase detected' is active if the combination of P and T indicates water.
58: IAPWS-IF97 Saturated steam In compliance with IAPWS-IF97, revised release, 2007 Uses T to define equilibrium pressure and density. Totals are disabled and alarm 'Liquid phase detected' is active if T<100°C.
59: IUPAC Ethylene In compliance with IUPAC International Thermodynamic Tables of the Fluid State Vol. 10 (1988)
60: API 11.3.3.2 Propylene In compliance with API MPMS 11.3.3.2 Propylene Compressibility Tables, 1974, Reaffirmed 1997.
61: ASTM D4311/4311M-09 Asphalt In compliance with ASTM D4311/4311M-09
62: ASTM D1550 Butadiene In compliance with ASTM D1550 Butadiene Measurement Tables, 1994, Reaffirmed 2005
63: NIST 1045 Ethylene In compliance with NIST 1045
64: API 11.3.2.1 Ethylene In compliance with API MPMS 11.3.2.1 Ethylene Ethylene density, 1974, Reaffirmed 1993
65: 54C Special applications API 11.1:2007 Special applications at 15°C (table 54C) procedure using a product specific 60°F thermal expansion factor and a (fixed) compressibility factor F for pressure correction (both configurable from the product configuration display). To be used for a.o. MTBE, gasohol.
66: 60C Special applications API 11.1:2007 Special applications at 20°C (table 60C) procedure using a product specific 60°F thermal expansion factor and a (fixed) compressibility factor F for pressure correction (both configurable from the product configuration display). To be used for a.o. MTBE, gasohol.
67: OIML-R22 Ethanol OIML-R22-1975 International Alcoholometric Tables for Ethanol / Water mixture. Base temperature for the Ethanol / Water mixture can be specified on display Configuration, Overall setup, Common settings. Next to the volume of the mixture at the mixture base temperature (represented as Gross standard volume), the flow computer calculates the ethanol volume at the ethanol base temperature

(represented as Net standard volume). The ratio between these two (called CSW) can be found on the BS&W display.

68: API 11.4.1 Water

In compliance with API 11.4.1:2018
Uses P and T to define density of water.

Use separate 1000
CTL and CPL
Only applicable to API 11.1:2007: Tables 5/6, 23/24, 53/54, 59/60

0: Disabled

The CTPL is calculated as (rounded) CTL * (rounded) CPL.

1: Enabled

The CTPL value from the standard (calculated as unrounded CTL * unrounded CPL) is used.

Density

Standard density override	1000	Defines whether the standard density override value for the product is used or not. 0: Disabled 1: Enabled
Standard density override	1000	The standard density override value for the product. The unit depends on the setting Standard density override unit type : relative density [-], API gravity [°API] or density [kg/sm3]. This value is used if the Standard density override of the product is enabled, or if the Standard density input type is set to 'Always use override' (see the paragraph on standard density for more details).
Std density override unit type	1000	The standard density units used for the override value. 1: Relative density [-] 2: API gravity [°API] 3: Density [kg/sm3]
Densitometer correction factor	1000	Densitometer correction factor (DCF). Only used if Use product DCF is enabled (see paragraph 'densitometer setup' for more information).

Equilibrium pressure

Equilibrium pressure mode	1000	Method to determine the equilibrium pressure. 1: Override value The 'Equilibrium pressure override value' is used for the calculation of the CPL value. 2: Standard The equilibrium pressure is calculated in accordance with the density conversion method Equilibrium pressure calculation is supported for NGL/LPG (GPA_TP15), water / steam (IAPWS-IF97), ethylene (IUPAC, NIST1045 or API 11.3.2.1) and propylene (API 11.3.3.2) 3: Antoine equation exponential The equilibrium pressure is calculated using the Antoine equation in exponential form:
---------------------------	------	---

$$P_e = e^{\left(A - \frac{B}{C+T}\right)}$$

with

P_e : equilibrium pressure [bar(a)]

T: meter temperature [°C]

A, B, C: Antoine coefficients

4: Antoine equation NIST

The equilibrium pressure is calculated using the Antoine equation as it is used in the NIST Standard Reference Database:

$$P_e = 10^{\left(A - \frac{B}{C+T+273.15}\right)}$$

		with P _e : equilibrium pressure [bar(a)] T: meter temperature [°C] A, B, C: Antoine coefficients
Equilibrium pressure override value	1000	The fixed equilibrium pressure value. Only used if equilibrium pressure mode of the product is set to 'Override value'.
TP15 P100 correlation	1000	Only applicable to NGL / LPG products with equilibrium pressure mode set to 'Standard'. Controls whether the basic or the improved GPA TP-15 correlation is applied for calculating the equilibrium pressure (= vapor pressure). 0: Disabled The basic correlation is commonly used for pure products such as propane, butane and natural gasoline. It only requires the relative density and the temperature to calculate the equilibrium pressure 1: Enabled The improved correlation requires the vapor pressure at 100°F. This method is better suited for varied NGL mixes, where different product mixes could have the same specific gravity but different equilibrium pressure
Vapor pressure at 100F	1000	The equilibrium pressure [bar(a)] of the product at 100 °F. Only applicable if TP15 P100 correlation is enabled.
Equilibrium pressure coefficient A, B, C	1000	Coefficients A, B, C for Antoine equation Only used if equilibrium pressure mode of the product is set to 'Antoine equation'.

Compressibility factor F

The compressibility factor F is used to calculate the CPL.

Compressibility override	1000	Enables or disables the compressibility factor F override value for the product. 0: Disabled The CPL is calculated from the compressibility factor F that is calculated by the standard 1: Enabled The CPL is calculated from the compressibility factor F override value.
Compressibility override	1000	Compressibility factor F override value

Thermal expansion coefficient

Thermal expansion coefficient	1000	Thermal expansion coefficient (alpha) for special applications (API table 54C/60C). Only applicable if density conversion method is set to '54C Special applications' or '60C Special applications'. Examples: MTBE: 1420.2 e-6 [1/°C], Gasohol: 1285.8 e-6 [1/°C]
-------------------------------	------	--

Isentropic exponent

The isentropic exponent is used for mass flow rate calculation in case of differential pressure flow meters.

Isentropic exponent override	1000	Enables or disables the isentropic exponent override value for the product. 0: Disabled 1: Enabled Isentropic exponent calculation is only supported for steam / water (IAPWS-IF97) and ethylene (IUPAC). For these products this option makes it possible to switch between the calculated and override value. For all other products the override value is used regardless of this setting.
Isentropic exponent override	1000	Override value for the isentropic exponent of the fluid at flowing conditions [-]

Dynamic viscosity

The dynamic viscosity is used for mass flow rate calculation in case of differential pressure flow meters.

Dynamic viscosity override	1000	Enables or disables the dynamic viscosity override value for the product. 0: Disabled 1: Enabled Dynamic viscosity calculation is only supported for ethylene (IUPAC). For this product this option makes it possible to switch between the calculated and override value. For all other products the override value is used regardless of this setting.
Dynamic viscosity override	1000	Dynamic viscosity of the liquid at flowing conditions [Pa.s].

Viscosity calculation

The viscosity value can be used to correct for the influence of the viscosity on turbine and PD flow meters. The viscosity can be measured or calculated according to the ASTM D341-09 standard. This calculation uses 3 product specific constants A, B, C, which can be configured in this section.

Viscosity constant A, B, C	1000	Constants A, B, C to calculate the kinematic viscosity according to ASTM D341-09 See paragraph 'Viscosity setup' for more details.
----------------------------	------	---

Auto product selection

These settings are used for auto product selection based on density. See paragraph 'Product selection' for more details.

Auto select density high limit	1000	High limit for the density of the product. Represents the observed density [kg/m ³] or standard density [kg/sm ³], depending on parameter Density interface – Density mode .
Auto select density high limit	1000	Low limit for the density of the product. Represents the observed density [kg/m ³] or standard density [kg/sm ³], depending on parameter Density interface – Density mode .

Meter run setup

The meter run configuration displays are only available for the following FC types:

- Run only
- Station /run
- Proving / run
- Station / proving / run

Run setup

This display contains the general run settings. Depending on the selections made in this display, specific configuration displays for detailed configuration will be available further down the menu.



Display → Configuration, Run <x>, Run setup

with <x> the number of the meter run

Meter type

Meter device type	1000	The following meter device types are supported:
		1: Pulse Any flow meter that provides a single or dual pulse signal representing the volumetric or mass flow. Typically used for turbine and PD (Positive displacement) flow meters.
		2: Smart Any flow meter that provides its flow rate and / or total value through an analog or HART signal or via a Modbus communications link. Typically used for ultrasonic and coriolis flow meters. For a HART signal or a Modbus communications link the corresponding communications device needs to be defined using the Flow-Xpress software, prior to writing the application to the flow computer
		3: Smart / pulse Any flow meter that provides its flow rate and / or total value through an analog or HART signal or via a Modbus communications link and also through a single or dual pulse signal. Either the smart or the pulse signal may be defined as the primary signal for totalization. Also a deviation check between the two signals is performed. Typically used for ultrasonic and coriolis flow meters that provide both a communications link and a pulse signal. For a HART signal or a Modbus communications link the corresponding communications device needs to be defined using the Flow-Xpress software, prior to writing the application to the flow computer.
		4: Orifice Orifice plate with up to 3 differential pressure transmitters.
		5: Venturi Classical venturi with up to 3 differential pressure transmitters.
		6: V-cone McCrometer V-Cone flow meter with up to 3 differential pressure transmitters.
		7: Venturi nozzle Venturi nozzle with up to 3 differential pressure transmitters.
		8: Long radius nozzle Long radius nozzle with up to 3 differential pressure transmitters.
		9: ISA1932 nozzle ISA1932 nozzle with up to 3 differential pressure

transmitters.

Meter temperature

Meter temperature transmitter(s)	1000	Defines if one or two transmitters are used for indicating the meter temperature. 0: Single One meter temperature transmitter 1: Dual Two meter temperature transmitters
----------------------------------	------	--

Meter pressure

Meter pressure transmitter(s)	1000	Defines if one or two transmitters are used for indicating the meter pressure. 0: Single One meter pressure transmitter 1: Dual Two meter pressure transmitters
-------------------------------	------	---

Density

These settings are only available if 'common density input' is disabled.

The settings are replicated from the 'Density setup' display. See the paragraph 'Density setup' for a description of the individual settings.

Observed density input type

Observed density input unit type

Density temperature input type

Density pressure input type

Standard density input type

Standard density input unit type



If an impossible combination of settings is chosen, then a 'Density configuration error' alarm is shown.

Product

The settings in this section are only available if 'common product and batching' is disabled.

Multiple products	1000	Defines whether the run uses one product or multiple products. 0: Disabled This run uses one fixed product only 1: Enabled This run uses multiple products
Single product number	1000	Fixed product number to be used for this run if 'Multiple products' is disabled.

Run control setup

From this display the run control functions, like valve control, flow control and sampler control can be enabled or disabled.

Depending on the selections made in this display, specific configuration displays for detailed configuration will be available further down the menu.



Display → Configuration, Run <x>, Run control setup

with <x> the number of the meter run

Valve control

Inlet valve	600	With this setting control of the inlet valve can be
-------------	-----	---

control signals		enabled or disabled (none=disabled). For a thorough explanation of this setting refer to paragraph 'Valve control'.
Outlet valve control signals	600	With this setting control of the outlet valve can be enabled or disabled (none=disabled). For a thorough explanation of this setting refer to paragraph 'Valve control'.
Run to prover valve control signals	600	With this setting control of the run to prover valve can be enabled or disabled (none=disabled). For a thorough explanation of this setting refer to paragraph 'Valve control'.

Flow / pressure control

Flow / pressure control mode	600	With this setting flow / pressure control (PID control) can be enabled or disabled (none=disabled). For a thorough explanation of this setting refer to paragraph 'Flow / pressure control'.
------------------------------	-----	--

Sampler control

Sampler control	600	With this setting sampler control can be enabled or disabled.
-----------------	-----	---

Flow meter setup

This section contains all flow meter specific settings.



The type of flow meter is set up under Configuration, Run <x>, Run Setup. Depending on the selected meter type, specific display screens for configuration of the meter are available.

Meter data



Display → Configuration, Run <x>, Flow meter, Meter data

with <x> the number of the meter run

Meter tag	600	Flow meter tag, e.g. 'FT-1023AA'
Meter ID	600	Flow meter ID, e.g. 'Check meter export 2'
Meter serial number	600	Flow meter serial number, e.g. 'H1009245'
Meter manufacturer	600	Name of the flow meter manufacturer
Meter model	600	Flow meter model, e.g. 'Promass 83'
Meter size	600	Flow meter size, e.g. '120 mm' or '11"'

Pulse input

This display is only available if **Meter device type** is 'Pulse' or 'Smart / Pulse'.



Display → Configuration, Run <x>, Flow meter, Pulse input

with <x> the number of the meter run

Pulse input module	1000	Number of the flow module to which the meter pulse is physically connected. -1: Local module means the module of the meter run
--------------------	------	---

		itself
Pulse input index	1000	Pulse input number [1-4]. Only applicable to version 2 hardware; must be set to 1 for version 1 hardware.
Pulse input quantity type	1000	Either 'Volumetric' for a volumetric flow meter (e.g. turbine, PD, ultrasonic) or 'Mass' for a mass flow meter (e.g. coriolis) 1: Volume 2: Mass

Meter active settings

Meter active threshold frequency	1000	Low flow cutoff frequency. When the actual frequency [Hz] is below this threshold value, the meter is considered to be inactive. Depending on the settings ' Disable totals when meter inactive ' and ' Set flow rate to 0 when meter inactive ' the totals are stopped and / or the flow rate is set to zero (refer to paragraph 'Overall setup').
Enable meter inactive custom condition	1000	If enabled, the 'meter inactive custom condition' of the meter run can be used to disable / enable the meter totals and / or set the flow rate to 0 through an internal 'calculation' or through communication. Should only be enabled if needed. 0: Disabled 1: Enabled

Custom pulse increment

Custom pulse increment	1000	If enabled, the totalizer increments are calculated from the value that is written to the 'Custom pulse increment' and the actual pulse input is not used. 0: Disabled 1: Enabled
------------------------	------	---

Smart meter

This display is only available if **Meter device type** is 'Smart' or 'Smart / Pulse'.



Display → Configuration, Run <x>, Flow meter, Smart meter

with <x> the number of the meter run

Input type

Smart meter input type	1000	Type of input used for the 'smart' flow meter 1: HART/Modbus (Serial, Ethernet or HART) 2: Analog input
Use flowrate or total	1000	Only applicable if smart meter input type = 'HART/Modbus'. Determines whether the flow rate or the flow total value as provided by the flow meter is used for flow totalization. 1: Flow rate 2: Flow total In case of an analog input the input always represents a flow rate.
Pulse is primary	1000	Only applicable if meter type is 'Smart / pulse'. Controls whether the pulse input or the smart input is used as the primary source for flow totalization. 0: No Smart input is primary 1: Yes Pulse input is primary
Fall back to secondary flow signal	1000	Only applicable if meter type is 'Smart / pulse'. Defines what happens if the primary input fails. 0: Disabled Don't use the secondary flow signal if the

		primary signal fails. The secondary signal is solely used for the deviation check.
	1: Enabled	Use the secondary flow signal if the primary signal fails while the secondary signal is healthy.

Analog input settings

Analog input quantity type	1000	Only applicable if smart meter input type = '2: Analog input' or input type is '1: HART/Modbus' with option 'HART to analog fallback' enabled 1: Volumetric 2: Mass For HART or Modbus inputs this setting is determined automatically from the communication tag list of the assigned communication device.
Analog input module	1000	Only applicable if smart meter input type = '2: Analog input' or input type is '1: HART/Modbus' with option 'HART to analog fallback' enabled Number of the flow module to which the analog signal is physically connected. -1: Local module means the module of the meter run itself
Analog input channel	1000	Only applicable if smart meter input type = '2: Analog input' or input type is '1: HART/Modbus' with option 'HART to analog fallback' enabled Number of the analog input channel on the selected module to which the analog signal is physically connected.

HART/Modbus settings

Smart meter internal device nr.	1000	Only applicable if smart meter input type = 'HART/Modbus'. Device nr. of the communication device as assigned in the configuration software (Flow-Xpress, section 'Ports & Devices')
HART to analog fallback	1000	Only applicable for a single HART transmitter in a loop, where the 4-20 mA signal is provided together with the HART signal. 0: Disabled The 4-20 mA signal will not be used if the HART signal fails. Instead the value corresponding with the 'Fallback type' will be used. 1: Enabled The 4-20 mA signal will be used if the HART signal fails. When both the HART and the mA signal fail the value corresponding with the 'Fallback type' will be used.

Meter active settings

Meter active threshold flow rate	1000	Low flow cutoff flow rate. The meter will be considered inactive when the flow rate is below this limit value. The value has the same units as the flow rate that is indicated by flow meter: [m3/hr] in case of a volume flow meter, [tonne/hr] in case of a mass flow meter. Depending on the settings ' Disable totals when meter inactive ' and ' Set flow rate to 0 when meter inactive ' the totals are stopped and / or the flow rate is set to zero if the flow rate is below this threshold (refer to paragraph 'Overall setup').
Enable meter inactive custom condition	1000	If enabled, the 'meter inactive custom condition' of the meter run can be used to disable / enable the meter totals and / or set the flow rate to 0 through an internal 'calculation' or through communication. Should only be enabled if needed. 0: Disabled 1: Enabled

Communication settings

Pulse K-factor selection	1000	Defines if the K factor (pulses/unit) is read from the meter or set manually. Only applicable if meter type is 'Smart / pulse'. 1: User parameter Use the K-factor that is configured in the flow computer
--------------------------	------	--

		2: Read from flow meter Use the K-factor that is read from the smart meter Note that communication of the K-factor via Modbus is not supported by all smart meters.
Pulse quantity type selection	1000	Defines if the pulse input quantity type (either mass or volume) is read from the meter or set manually. 1: User parameter Use the quantity type that is configured in the flow computer 2: Read from flow meter Use the quantity type that is read from the smart meter Note that communication of the quantity type via Modbus is not supported by all smart meters.
Flow meter total rollover	1000	Only applicable for a smart meter of which the 'Flow total' is used for flow accumulation. Defines the value at which the total as received from the flow meter rolls-over to 0. When the current total value indicated by the flow meter is smaller than the previous value total, then the Flow-X calculates the increment assuming that a roll-over occurred. It then checks that the increment does not exceed the 'Flow Meter Max. Change In Total'. Unit is [m3] in case of a volume flow meter, [tonne] in case of a mass flow meter.
Flow meter max. change in total	1000	Only applicable for a smart meter of which the 'Flow total' is used for flow accumulation. Total increments beyond this limit will be ignored. This may f.e. happen in case the totalizer in the meter is reset or when the meter is replaced. Unit is [m3] in case of a volume flow meter, [tonne] in case of a mass flow meter.

Flow rate deviation check

Flow deviation limit smart / pulses	600	Only applicable if meter type is 'Smart / pulse'. The flow rates as indicated by the smart and pulse inputs are compared and a 'Smart / pulse flow deviation' alarm is raised if the relative deviation between the two is larger than this Flow deviation limit [%].
-------------------------------------	-----	--

Batch total deviation check

Meter/FC batch total deviation check	600	Only applicable if meter type is 'Smart / pulse'. Enables / disables a deviation check between the previous batch total calculated from the totals at batch start / end as read from the flow meter and the previous batch total calculated by the flow computer. 0: Disabled 1: Enabled
Meter/FC batch total deviation limit	600	Maximum allowable deviation between the batch total calculated from the totals at batch start / end as read from the flow meter and the previous batch total calculated by the flow computer. Unit is [m3] in case of a volume flow meter, [tonne] in case of a mass flow meter.

Meter K-factor

Only available if Meter device type is 'Pulse input' or 'Smart / pulse'

To convert meter pulses in metered volume a meter K-factor is used. The meter K-factor value can be defined in two ways, either as a nominal meter K-factor value that is applied for all flow rates or as a calibration curve, where a number of calibrated K-factors is defined as a function of the actual pulse frequency.



Display → Configuration, Run <x>, Flow meter, Meter K-factor(, K-factor setup)

With <x> the number of the meter run

Nominal K-factor

Nominal K-factor (forward / reverse)	1000	The number of pulses per unit, with the unit being m3 for volumetric flow meters, or tonne for mass flow meters. Separate nominal K-factors are maintained for forward and reverse flow directions. Nominal K-factors are only used if K-factor curve interpolation is disabled. The reverse nominal K-factor is only used if reverse totalizers are enabled.
--------------------------------------	------	---

K-factor curve

K-factor curve	1000	Controls whether the nominal K-factor or the calibration curve is used. 0: Disabled Nominal K-factor is used 1: Enabled Calibration curve is used.
Curve extrapolation allowed	1000	Controls if extrapolation is allowed when the pulse frequency is outside the calibration curve 0: No When the pulse frequency is below the first calibration point or above the last calibration point, then respectively the first or the last calibration K-factor will remain in-use. 1: Yes The interpolation is extrapolated when the pulse frequency is outside the calibrated range.

K-factor curve (forward / reverse)



Display → Configuration, Run <x>, Flow meter, Meter K-factor, K-factor curve (forward / reverse)

With <x> the number of the meter run

K-factor curves are only visible if K-factor curve interpolation is enabled. The reverse K-factor curve is only visible if reverse totalizers are enabled.

Point x – Frequency	1000	Pulse frequency [Hz] of the calibration point
Point x – K-factor	1000	Meter K-factor [pls/unit] of the calibration point.

Remarks:

- Pulse frequency must be in ascending order
- Up to 12 points can be defined. For unused points, leave the pulse frequency to 0. E.g. if the curve has 6 points, the pulse frequency of points 7 through 12 must be set to 0.

Meter factor / error

To correct for a meter error that was determined at a meter calibration, the volume or mass as indicated by the meter can be corrected with either one nominal meter factor for all flow rates, or a calibration curve that defines the meter factor as a function of the flow rate.

Because meter calibration reports specify either the **meter factor** or the **meter error** as a function of the flow rate, the flow computer accommodates the entry of either value. The relationship between the meter error and the meter factor as follows:

$$\text{Meter factor} = 100 / (100 + \text{Meter error})$$

(with the meter error specified as a percentage).

By default a nominal meter factor of 1 is used, so effectively disabling the correction.

Nominal meter factors / errors and meter factor / error curves are product-dependent. For each of the up to 16 products a different nominal meter factor / error or meter factor / error curve is applied.

Furthermore, separate nominal meter factors / errors and separate meter factor / error curves are used for forward and reverse flow.



Display → Configuration, Run <x>, Flow meter, Meter factor(, Meter factor setup)

With <x> the number of the meter run

Type of input value	1000	Defines the meaning of the entered values. Applies for both the nominal value and the calibration curve values. 1: Meter factor [-] 2: Meter error [%]
---------------------	------	--

Meter factor / error curve

Meter factor / error curve	1000	Controls whether the nominal meter factor / error or the calibration curve is used. 0: Disabled Nominal value is used 1: Enabled Calibration curve is used.
Curve extrapolation allowed	1000	Controls if extrapolation is allowed when the flow rate is outside the calibration curve 0: No When the flow rate is below the first calibration point or above the last calibration point, respectively the first or the last calibration error will remain in-use. 1: Yes The interpolation is extrapolated when the pulse frequency is outside the calibrated range.
Curve flow rate corrected for MBF	1000	Only applicable if meter factor / error curve interpolation is enabled and meter body correction is enabled. Determines whether or not the flow computer applies the MBF (Meter Body Correction Factor) to the flow rate before using it in meter factor interpolation. 0: Disabled Uncorrected flow rate is used in meter factor / error curve interpolation 1: Enabled Corrected flow rate is used in meter factor / error curve interpolation

Prove base flow rate (forward or reverse)	1000	Only applicable if meter factor / error curve interpolation is enabled. Base flow rate at which the offset from the meter factor curve is calculated. [m ³ /hr] in case of a volume flow meter, [tonne/hr] in case of a mass flow meter. The actual prove flow rate should not differ too much from this prove base flow rate.
---	------	--

Meter factor offset

Meter factor offset (forward or reverse)		Only applicable if meter factor / error curve interpolation is enabled. Offset from the meter factor curve as determined from proving. Calculated by the flow computer based on the prove result.
--	--	---

Custom meter factor

Custom meter factor	1000	If enabled, the meter factor value that is written to the 'Custom meter factor' is used instead of the nominal or curve meter factor / error. 0: Disabled 1: Enabled
---------------------	------	--

Prove required flags and alarms

Prove required flags	1000	Enables one or more flags that indicate that a new prove is needed due to a change of flow rate, density, temperature, pressure or viscosity, or because the maximum flow between proves has been exceeded. 0: Disabled 1: Enabled
Prove required alarms	1000	If enabled, an alarm is generated when a prove required flag is raised. 0: Disabled 1: Enabled

When the prove required flags are enabled, there will be an extra operator display → Flow meter, Run <x>, Meter factor, Prove required flags, from which the detailed configuration can be done.

The prove required flags may be used as a trigger for a PLC, HMI or custom calculation to automatically start a prove. Alternatively, the operator may be triggered by the prove required alarm to manually conduct a prove.

Nominal meter factors / errors

The flow computer uses separate nominal meter factors / errors for each product as well as separate nominal meter factors / errors for forward and reverse flow direction. As there are maximum 16 products, 32 nominal meter factors / errors can be defined.

Nominal meter factors / errors are only visible if meter factor / error curve interpolation is disabled.

The reverse nominal meter factors / errors are only visible if reverse totalizers are enabled.



Display → Configuration, Run <x>, Flow meter, Meter factor, Meter factors (fwd / rev), Product <y>

With <x> the number of the meter run and <y> the product number

Nominal meter factor / error	1000	The nominal meter factor [-] or error [%] used for a specific product in a specific flow direction (forward / reverse).
------------------------------	------	---

Meter factor / error curves

The flow computer uses separate meter factor / error curves for each product as well as separate curves for forward and reverse flow direction. As there are maximum 16 products, 32 meter factor / error curves can be defined.

Meter factor / error curves are only visible if meter factor / error curve interpolation is enabled.

The reverse meter factor / error curves are only visible if reverse totalizers are enabled.



Display → Configuration, Run <x>, Flow meter, Meter factor, Meter factors curves, Product <y>

With <x> the number of the meter run and <y> the product number

Point x – Flow rate	1000	Flow rate [unit/h] of the calibration point
Point x – Meter factor / error	1000	Meter factor [-] or Meter error [%] of the calibration point, depending on the selected Type of input value .

Remarks:

- Flow rates must be in ascending order
- Up to 12 points can be defined. For unused points, leave the flow rate to 0. E.g. when the curve has 6 points, the flow rates of points 7 through 12 must be set to 0.

Meter factor offset

Meter factor offset		Offset from the meter factor curve as determined from proving. Calculated by the flow computer based on the prove result.
---------------------	--	--

Data valid input

The Data valid input is an optional input that can be used to control the accountable totals (for MID compliance). It is usually only applicable for smart flow meters (e.g. ultrasonic or coriolis) that provide a data valid output signal.

The Data Valid can also be used as a permissive for flow control.



Display → Configuration, Run <x>, Flow meter, Data valid input

with <x> the number of the meter run

Data valid input type	1000	Selects the data valid input type 0: None Data valid check is disabled 1: Digital input
-----------------------	------	--

		Reads the data valid status from a digital input
		2: Smart meter input Uses the data valid status from the flow meter Modbus communication
		3: Custom The value that is written to tag Data valid custom condition will be used. Use this option if the data valid condition is sent to the flow computer over a Modbus communications link or if you want to apply user-defined calculations to the data valid condition.
Data valid digital input module	1000	Only applicable if Data valid input type is 'Digital input'. Number of the flow module to which the signal is physically connected. -1: Local module means the module of the meter run itself
Data valid digital input channel	1000	Only applicable if Data valid input type is 'Digital input'. Number of the digital channel on the selected module to which the signal is physically connected.

Flow direction

Only available if **Reverse totals** are enabled (Display → Configuration, Overall setup, Common settings)

The flow direction is used to switch between the forward and reverse totals and averages.



Display → Configuration, Run <x>, Flow meter, Flow direction

with <x> the number of the meter run

Flow direction input

Flow direction input type	1000	Selects the flow direction input type 1: Meter pulse phase Only applies to dual pulse meters. The flow direction is derived from the sequence of the dual pulses. See paragraph 'Pulse input' for more details. 2: Digital input Reads the flow direction status from a digital input (0: Forward, 1: Reverse) 3: Smart meter modbus Uses the flow direction from the flow meter Modbus communication 4: Custom The value that is written to tag Flow direction custom value will be used. Use this option if the flow direction value is sent to the flow computer over a Modbus communications link or if you want to apply user-defined calculations to the flow direction.
Flow direction digital input module	1000	Only applicable if Flow direction input type is 'Digital input'. Number of the flow module to which the signal is physically connected. -1: Local module means the module of the meter run itself
Flow direction digital input channel	1000	Only applicable if Flow direction input type is 'Digital input'. Number of the digital channel on the selected module to which the signal is physically connected.

Flow direction output

Flow direction	600	Enables / disables the flow direction digital
----------------	-----	---

digital output		output. 0: Disabled 1: Enabled
Flow direction digital output module	600	Number of the flow module to which the signal is physically connected. -1: Local module means the module of the meter run itself
Flow direction digital output channel	600	Number of the digital channel on the selected module to which the signal is physically connected.

Meter body correction

Only available if Meter device type is 'Pulse', 'Smart' or 'Smart/Pulse'

The meter body correction facility is mainly meant for ultrasonic flow meters for which a correction of the expansion of the meter body may be required.

The meter body factor (MBF) accounts for the influence of temperature and pressure on the meter's steel.

Refer to chapter Calculations for more details



Display → Configuration, Run <x>, Flow meter, Meter body correction

with <x> the number of the meter run



If the flow rate value indicated by the smart flow meter already includes the correction for meter body expansion, then the **Meter Body Correction** in the flow computer must be disabled.

Meter body correction	1000	Controls whether meter body correction is enabled or not 0: Disabled 1: Enabled
Meter body correction type	1000	Controls how the meter body correction factor is calculated 1: Formula Calculated the meter body correction factor using the formula: $MBF = 1 + Temp\ coef * (T - Tref) + Pres\ coef * (P - Pref)$ 2: Custom Uses the value [-] that is written to the Custom meter body correction factor . Use this option if you want to apply user-defined calculations to the meter body correction factor.

Calculation constants

Body correction reference temperature	1000	Reference temperature for body correction [°C]
Body correction reference pressure	1000	Reference pressure for body correction [bar(g)]
Meter body coefficient selection	1000	1: Use parameter Uses the body expansion coefficients that are configured in the flow computer

2: Read from flow meter
 Uses the body expansion coefficients that are read from the smart meter
 Note that communication of the body expansion coefficients via Modbus is not supported by all smart meters.

User coefficients

Cubical temperature expansion coefficient	1000	Cubical temperature expansion coefficient [1/K] (same as 1/°C) Equals linear temperature expansion coefficient multiplied by 3. Typical values are 4.12 E-5 for carbon steel and 5.23 E-5 for stainless steel.
Cubical pressure expansion coefficient	1000	Cubical pressure expansion coefficient [1/bar] Equals linear pressure expansion coefficient multiplied by 3. Typical value is 6 E-6 both for carbon steel and stainless steel.

Viscosity correction

The application supports a viscosity input. The viscosity value can be used to calculate a viscosity correction factor (LCF) that corrects for the influence of the viscosity on turbine and PD flow meters.

Refer to chapter Calculations for more details



Display → Configuration, Run <x>, Flow meter, Viscosity correction

with <x> the number of the meter run

Viscosity correction	1000	Controls whether viscosity correction is enabled or not 0: Disabled 1: Enabled
Viscosity correction type	1000	1: Helical turbine Viscosity correction factor calculation for helical turbines, using coefficients A,B,C,D,E,F,G 2: PD meter Viscosity correction factor calculation for PD meters, using coefficients A,B,C 3: ISO 4124:1994 Viscosity correction factor calculation according to ISO 4124:1994, using coefficients a0,a1,a2,a3,a4,a5,a6 4: Custom Uses the value [-] that is written to the Custom viscosity correction factor . Use this option if you want to apply user-defined calculations to the viscosity correction factor.

Calculation limits

Viscosity correction maximum flow rate	1000	Maximum flow rate [m3/hr] for which the viscosity correction is applied. For flow rates above this limit viscosity correction is disabled.
Viscosity correction minimum flow rate	1000	Minimum flow rate [m3/hr] for which the viscosity correction is applied. For flow rates below this limit viscosity correction is disabled.
Viscosity correction maximum viscosity	1000	Maximum viscosity [cSt] for which the viscosity correction is applied. If the viscosity is above this limit, viscosity correction is disabled.
Viscosity correction minimum	1000	Minimum flow rate [cSt] for which the viscosity correction is applied. If the viscosity is below this limit, viscosity

viscosity		correction is disabled.
Maximum allowable calculated LCF	1000	If the calculated LCF lies above this value, it will be ignored and a correction factor of 1 will be used instead.
Minimum allowable calculated LCF	1000	If the calculated LCF lies below this value, it will be ignored and a correction factor of 1 will be used instead.

Helical turbine

Viscosity coefficients A-G	1000	Coefficients A, B, C, D, E, F and G for viscosity correction factor calculation for helical turbine meters
----------------------------	------	--

PD meter

Viscosity coefficients A-C	1000	Coefficients A, B, C for viscosity correction factor calculation for PD meters
----------------------------	------	--

ISO 4124:1994

Viscosity coefficients a0-a6	1000	Coefficients a0,a1,a2,a3,a4,a5,a6 for viscosity correction factor calculation according to ISO 4124:1994
------------------------------	------	--

Indicated totalizers

From this display the (forward and reverse) indicated totalizers can be adjusted.



Display → Configuration, Run <x>, Flow meter, Indicated totalizers

with <x> the number of the meter run

This feature can be used to make the indicated totalizers on the flow computer run in line with the totalizers indicated on the meter. This is mainly applicable to ultrasonic meters and coriolis meters that have a display showing an (indicated) volume or mass totalizer.

The unit of the indicated totalizer is either [m3] or [tonne] depending on the meter quantity type.

Forward totalizer

Preset fwd indicated totalizer value	1000	New value ([m3] or [tonne]) for the forward indicated totalizer
Accept fwd totalizer	1000	Command to accept the new value for the forward indicated totalizer

Reverse totalizer

Preset rev indicated totalizer	1000	New value ([m3] or [tonne]) for the reverse indicated totalizer
Accept rev totalizer	1000	Command to accept the new value for the reverse indicated totalizer

Serial mode

Only applicable for FC types:

- Station/run
- Station/proving/run
- 'Run only' FC with the run being part of a remote station

Serial mode avoids the totals of meters that are set in a serial configuration to be added together in a station total. If serial

mode for a run is active, the totalizers of that run are not taken into account in the station totalizers.



Display → Configuration, Run <x>, Flow meter, Serial mode

with <x> the number of the meter run

Serial mode can be activated by manual command, or from a digital input. The digital input may be connected to a status output of a 'crossover valve', by which 2 meters can be put into serial configuration. From this valve status the flow computer then can detect if the meters are in serial configuration or not.

Serial mode	1000	Enables or disables the serial mode logic for this meter. 0: Disabled 1: Enabled
-------------	------	--

Serial mode input type

Serial mode input type	1000	Enables or disables the serial mode logic for this meter. 0: None Serial mode logic is disabled 1: Manual The meter is set into / put out of serial mode by manual commands 2: Digital input The meter is set into / put out of serial mode by reading a digital input. 3: Custom Uses the status that is written to the Serial mode custom input value . Use this option if the serial mode status is received through a Modbus communications link, or if you want to apply user-defined logic to the serial mode status.
------------------------	------	--

Serial mode digital input

Serial mode digital input module	1000	Only applicable if Serial mode input type is 'Digital input'. Number of the flow module to which the signal is physically connected. -1: Local module means the module of the meter run itself
Serial mode digital input channel	1000	Only applicable if Serial mode input type is 'Digital input'. Number of the digital channel on the selected module to which the signal is physically connected.
Serial mode digital input polarity	1000	Only applicable if Serial mode input type is 'Digital input'. Polarity of the digital input to which the signal is physically connected. 1: Normal 2: Inverted

Serial mode switch permissive

Serial mode switch permissive	600	Determines whether or not a serial mode switch permissive is taken into account. If enabled the run can only be manually put into / out of serial mode if the serial mode switch permissive (to be written through Modbus or using a 'custom calculation') is ON. 0: Disabled 1: Enabled
-------------------------------	-----	--

Orifice

For orifice plates in accordance with ISO-5167 or AGA-3.

Only available if Meter device type is 'Orifice'



Display → Configuration, Run <x>, Flow meter, Orifice

with <x> the number of the meter run

Meter active settings

Low flow cutoff dP	1000	Meter active threshold dP. The meter will be considered inactive when the actual differential pressure [mbar] is below this limit value. Depending on the settings ' Disable totals when meter inactive ' and ' Set flow rate to 0 when meter inactive ' the totals are stopped and / or the flow rate is set to zero (refer to paragraph 'Overall setup').
Enable meter inactive custom condition	1000	If enabled, the 'meter inactive custom condition' of the meter run can be used to disable / enable the meter totals and / or set the flow rate to 0 through an internal 'calculation' or through communication. Should only be enabled if needed. 0: Disabled 1: Enabled

Calculation method

Orifice calculation method	1000	Defines the standard used for the calculations 1: ISO-5167 2: AGA-3
ISO5167 edition	1000	The edition of the ISO-5167 standard to be used for the flow calculations. 1: 1991 2: 1998 3: 2003 Only applicable if Orifice calculation method is 'ISO-5167'

Pipe settings

Pipe diameter	1000	Internal pipe diameter [mm]
Pipe reference temperature	1000	Reference temperature for the specified pipe diameter [°C]
Pipe expansion factor -type	1000	Selects the pipe material. Used to set the pipe linear thermal expansion factor. 1: Carbon steel 1.12e-5 [1/°C] 2: Stainless steel 304 1.73e-5 [1/°C] 3: Stainless steel 316 1.59e-5 [1/°C] 4: Monel 1.43e-5 [1/°C] 5: User-defined (uses the 'Pipe expansion factor - user')
Pipe expansion factor -user	1000	User-defined value for pipe linear thermal expansion factor [1/°C] Only used when Pipe expansion factor - type is set to 'User-defined'

Device settings

Device diameter	1000	Orifice internal diameter [mm]
Device reference temperature	1000	Reference temperature for the specified device diameter [°C]
Device expansion factor - type	1000	Selects the orifice material. Used to set the device linear thermal expansion factor. 1: Carbon steel 1.12e-5 [1/°C] 2: Stainless steel 304 1.73e-5 [1/°C]

		3: Stainless steel 316 1.59e-5 [1/°C]
		4: Monel 1.43e-5 [1/°C]
		5: User-defined (uses the Device expansion factor - user)
Device expansion factor - user	1000	User-defined value for device linear thermal expansion factor [1/°C] Only used when Device expansion factor - type is set to 'User-defined'
Orifice configuration	1000	Location of the pressure tapplings in accordance with the ISO5167 standard: 1: Corner tapplings 2: D and D/2 tapplings 3: Flange tapplings Only applicable if Orifice calculation method is 'ISO-5167'

Pressure settings

Pressure location	1000	Location of the pressure tap used for the static pressure relative to the orifice plate. 1: Upstream tapping 2: Downstream tapping If 'Downstream tapping' is selected, a correction of the meter pressure to upstream conditions is applied. Refer to chapter Calculations for more details
-------------------	------	---

Temperature settings

Temperature transmitter location	1000	Only applicable to steam Location of the temperature element relative to the orifice plate 1: Upstream tapping 2: Downstream tapping 3: Recovered pressure position Downstream at the location where the pressure has fully recovered. If 'Downstream tapping' or 'Recovered pressure position' is selected, a correction of the meter temperature to upstream conditions is applied. Refer to chapter Calculations for more details
Temperature correction	1000	Only applicable to steam This parameter specifies how the temperature must be corrected from downstream / recovered to upstream conditions 1: Isentropic exponent Isentropic expansion using $(1-\kappa)/\kappa$ as the temperature referral exponent 2: Temperature exponent Isentropic expansion using the 'Temperature Exponent' parameter value as the temperature referral exponent [-]. Please note that the 'Temperature Exponent' must be < 0 3: Joule Thomson Isenthalpic expansion using the 'Temperature Exponent' as the Joule Thomson coefficient [°C/bar]. This method is prescribed by ISO5167-1:2003.
Temperature exponent	1000	Only applicable to steam Only used when temperature has to be corrected to upstream conditions and type of temperature correction is either 'Temperature exponent' or 'Joule Thomson'.

AGA 3 settings

AGA3 fpwl correction factor	1000	Gravitational correction factor (Fpwl) for the AGA3 calculations Only applicable if Orifice calculation method is 'AGA-3'
-----------------------------	------	---

Product properties

Dynamic		Dynamic viscosity [Pa.s] of the selected product.
---------	--	---

viscosity		Configurable from the product configuration display.
Isentropic exponent		Isentropic exponent [-] at flowing conditions of the selected product. Configurable from the product configuration display.

Venturi

For classical venturi tubes in accordance with ISO-5167.

Only available if Meter device type is 'Venturi'



Display → Configuration, Run <x>, Flow meter, Venturi
with <x> the number of the meter run

Meter active settings

Low flow cutoff dP	1000	Meter active threshold dP. The meter will be considered inactive when the actual differential pressure [mbar] is below this limit value.
Enable meter inactive custom condition	1000	If enabled, the 'meter inactive custom condition' of the meter run can be used to disable / enable the meter totals and / or set the flow rate to 0 through an internal 'calculation' or through communication. Should only be enabled if needed. 0: Disabled 1: Enabled

Pipe settings

Pipe diameter	1000	Internal pipe diameter [mm]
Pipe reference temperature	1000	Reference temperature for the specified pipe diameter [°C]
Pipe expansion factor -type	1000	Selects the pipe material. Used to set the pipe linear thermal expansion factor. 1: Carbon steel 1.12e-5 [1/°C] 2: Stainless steel 304 1.73e-5 [1/°C] 3: Stainless steel 316 1.59e-5 [1/°C] 4: Monel 1.43e-5 [1/°C] 5: User-defined (uses the 'Pipe expansion factor - user')
Pipe expansion factor -user	1000	User-defined value for pipe linear thermal expansion factor [1/°C] Only used when Pipe expansion factor - type is set to 'User-defined'

Device settings

Device diameter	1000	Venturi internal diameter [mm]
Device reference temperature	1000	Reference temperature for the specified device diameter [°C]
Device expansion factor - type	1000	Selects the venturi material. Used to set the device linear thermal expansion factor. 1: Carbon steel 1.12e-5 [1/°C] 2: Stainless steel 304 1.73e-5 [1/°C] 3: Stainless steel 316 1.59e-5 [1/°C] 4: Monel 1.43e-5 [1/°C] 5: User-defined (uses the Device expansion factor - user)
Device	1000	User-defined value for device linear thermal

expansion factor - user		expansion factor [1/°C] Only used when Device expansion factor - type is set to 'User-defined'
Venturi configuration	1000	ISO5167 specifies different discharge coefficients for the different fabrication methods. 1: As cast convergent section 2: Rough welded 3: Machined 4: User-defined When 'User-defined' is selected then the parameter 'Discharge coefficient' will be used in the calculations instead. Note that this option is not in accordance to the standard.

Discharge coefficient

Discharge coefficient	1000	The user-defined discharge coefficient. Only used if parameter Venturi configuration is set to 'User-defined'.
-----------------------	------	--

Pressure settings

Pressure transmitter location	1000	Location of the pressure tap used for the static pressure relative to the orifice plate. 1: Upstream tapping 2: Downstream tapping If 'Downstream tapping' is selected, a correction of the meter pressure to upstream conditions is applied. Refer to chapter Calculations for more details
-------------------------------	------	---

Pressure loss mode	1000	The method for determining the pressure loss over the venturi tube 1: Absolute value The pressure loss is taken as an absolute value (as set in parameter 'Pressure Loss Value') 2: Percentage of dP The pressure loss value is taken as a percentage of the differential pressure. The percentage is as set in parameter 'Pressure Loss Value'.
Pressure loss value	1000	The pressure loss value either as an absolute value [mbar] or as a percentage [%] of dP.

Temperature settings

Temperature transmitter location	1000	Only applicable to steam Location of the temperature element relative to the venturi tube 1: Upstream tapping 2: Downstream tapping 3: Recovered pressure position Downstream at the location where the pressure has fully recovered. If 'Downstream tapping' or 'Recovered pressure position' is selected, a correction of the meter temperature to upstream conditions is applied. Refer to chapter Calculations for more details
----------------------------------	------	---

Temperature correction	1000	Only applicable to steam This parameter specifies how the temperature must be corrected from downstream / recovered to upstream conditions 1: Isentropic exponent Isentropic expansion using $(1-\kappa)/\kappa$ as the temperature referral exponent 2: Temperature exponent Isentropic expansion using the 'Temperature Exponent' parameter value as the temperature referral exponent [-]. Please note that the 'Temperature Exponent' must be < 0 3: Joule Thomson Isenthalpic expansion using the 'Temperature Exponent' as the Joule Thomson coefficient [°C/bar]. This method is prescribed by ISO5167-1:2003.
Temperature	1000	Only applicable to steam

exponent		Only used when temperature has to be corrected to upstream conditions and type of temperature correction is either 'Temperature exponent' or 'Joule Thomson'.
----------	--	---

Product properties

Dynamic viscosity		Dynamic viscosity [Pa.s] of the selected product. Configurable from the product configuration display.
Isentropic exponent		Isentropic exponent [-] at flowing conditions of the selected product. Configurable from the product configuration display.

V-cone

Settings for McCrometer V-cone and wafer cone flow meters.

Only available if Meter device type is 'V-cone'



Display → Configuration, Run <x>, Flow meter, V-cone
with <x> the number of the meter run

Meter active settings

Low flow cutoff dP	1000	Meter active threshold dP. The meter will be considered inactive when the actual differential pressure [mbar] is below this limit value. Depending on the settings ' Disable totals when meter inactive ' and ' Set flow rate to 0 when meter inactive ' the totals are stopped and / or the flow rate is set to zero (refer to paragraph 'Overall setup').
Enable meter custom condition	1000	If enabled, the 'meter inactive custom condition' of the meter run can be used to disable / enable the meter totals and / or set the flow rate to 0 through an internal 'calculation' or through communication. Should only be enabled if needed. 0: Disabled 1: Enabled

Pipe settings

Pipe diameter	1000	Internal pipe diameter [mm]
Pipe reference temperature	1000	Reference temperature for the specified pipe diameter [°C]
Pipe expansion factor -type	1000	Selects the pipe material. Used to set the pipe linear thermal expansion factor. 1: Carbon steel 1.12e-5 [1/°C] 2: Stainless steel 304 1.73e-5 [1/°C] 3: Stainless steel 316 1.59e-5 [1/°C] 4: Monel 1.43e-5 [1/°C] 5: User-defined (uses the 'Pipe expansion factor - User')
Pipe expansion factor -user	1000	User-defined value for pipe linear thermal expansion factor [1/°C] Only used if Pipe expansion factor - type is set to 'User-defined'

Device settings

Device diameter	1000	V-cone internal diameter [mm]
Device reference temperature	1000	Reference temperature for the specified device diameter [°C]
Device expansion	1000	Selects the V-cone material. Used to set the device linear thermal expansion factor.

factor - type		1: Carbon steel 1.12e-5 [1/°C] 2: Stainless steel 304 1.73e-5 [1/°C] 3: Stainless steel 316 1.59e-5 [1/°C] 4: Monel 1.43e-5 [1/°C] 5: User-defined (uses the Device expansion factor - user)
Device expansion factor - user	1000	User-defined value for device linear thermal expansion factor [1/°C] Only used if Device expansion factor - type is set to 'User-defined'
V-cone configuration	1000	V-cone configuration: 1: Standard V-cone 2: Wafer cone

Pressure settings

Pressure location	1000	Location of the pressure tap used for the static pressure relative to the v-cone. 1: At upstream tapping 2: Downstream tapping If 'Downstream tapping' is selected, a correction of the meter pressure to upstream conditions is applied. Refer to chapter Calculations for more details
-------------------	------	---

Temperature settings

Temperature transmitter location	1000	Only applicable to steam Location of the temperature element relative to the v-cone 1: Upstream tapping 2: Downstream tapping 3: Recovered pressure position Downstream at the location where the pressure has fully recovered. If 'Downstream tapping' or 'Recovered pressure position' is selected, a correction of the meter temperature to upstream conditions is applied. Refer to chapter Calculations for more details
Temperature correction	1000	Only applicable to steam This parameter specifies how the temperature must be corrected from downstream / recovered to upstream conditions 1: Isentropic exponent Isentropic expansion using $(1-\kappa)/\kappa$ as the temperature referral exponent 2: Temperature exponent Isentropic expansion using the 'Temperature Exponent' parameter value as the temperature referral exponent [-]. Please note that the 'Temperature Exponent' must be < 0 3: Joule Thomson Isenthalpic expansion using the 'Temperature Exponent' as the Joule Thomson coefficient [°C/bar]. This method is prescribed by ISO5167-1:2003.
Temperature exponent	1000	Only applicable to steam Only used when temperature has to be corrected to upstream conditions and type of temperature correction is either 'Temperature exponent' or 'Joule Thomson'.

Discharge coefficient

Discharge coefficient	1000	The discharge coefficient of the v-cone.
-----------------------	------	--

Product properties

Dynamic viscosity		Dynamic viscosity [Pa.s] of the selected product. Configurable from the product configuration display.
-------------------	--	---

Isentropic exponent		Isentropic exponent [-] at flowing conditions of the selected product. Configurable from the product configuration display.
---------------------	--	--

Venturi nozzle, long radius nozzle and ISA1932 nozzle

For venturi nozzles, long radius nozzles and ISA1932 nozzles in accordance with ISO-5167.

Only available if Meter device type is 'Venturi nozzle', 'Long radius nozzle' or 'ISA1932 nozzle'



Display → Configuration, Run <x>, Flow meter, Venturi nozzle

Display → Configuration, Run <x>, Flow meter, Long radius nozzle

Display → Configuration, Run <x>, Flow meter, ISA1932 nozzle
with <x> the number of the meter run

Meter active settings

Low flow cutoff dP	1000	Meter active threshold dP. The meter will be considered inactive when the actual differential pressure [mbar] is below this limit value. Depending on the settings ' Disable totals when meter inactive ' and ' Set flow rate to 0 when meter inactive ' the totals are stopped and / or the flow rate is set to zero (refer to paragraph 'Overall setup').
Enable meter inactive custom condition	1000	If enabled, the 'meter inactive custom condition' of the meter run can be used to disable / enable the meter totals and / or set the flow rate to 0 through an internal 'calculation' or through communication. Should only be enabled if needed. 0: Disabled 1: Enabled

Calculation method

ISO5167 edition	1000	The edition of the ISO-5167 standard to be used for the flow calculations. 1: 1991 2: 1998 3: 2003 Only applicable to long radius nozzles and ISA1932 nozzles
-----------------	------	---

Pipe settings

Pipe diameter	1000	Internal pipe diameter [mm]
Pipe diameter	1000	Internal pipe diameter [mm]
Pipe reference temperature	1000	Reference temperature for the specified pipe diameter [°C]
Pipe expansion factor -type	1000	Selects the pipe material. Used to set the pipe linear thermal expansion factor. 1: Carbon steel 1.12e-5 [1/°C] 2: Stainless steel 304 1.73e-5 [1/°C] 3: Stainless steel 316 1.59e-5 [1/°C] 4: Monel 1.43e-5 [1/°C] 5: User-defined (uses the 'Pipe expansion factor - user')
Pipe expansion	1000	User-defined value for pipe linear thermal

factor - user	expansion factor [1/°C] Only used when Pipe expansion factor - type is set to 'User-defined'
---------------	--

Device settings

Device diameter	1000	Nozzle internal diameter [mm]
Device reference temperature	1000	Reference temperature for the specified device diameter [°C]
Device expansion factor - type	1000	Selects the nozzle material. Used to set the device linear thermal expansion factor. 1: Carbon steel 1.12e-5 [1/°C] 2: Stainless steel 304 1.73e-5 [1/°C] 3: Stainless steel 316 1.59e-5 [1/°C] 4: Monel 1.43e-5 [1/°C] 5: User-defined (uses the Device expansion factor - user)
Device expansion factor - user	1000	User-defined value for venturi linear thermal expansion factor [1/°C] Only used when Device expansion factor - type is set to 'User-defined'

Pressure settings

Pressure transmitter location	1000	Location of the pressure tap used for the static pressure relative to the nozzle. 1: Upstream tapping 2: Downstream tapping If 'Downstream tapping' is selected, a correction of the meter pressure to upstream conditions is applied. Refer to chapter Calculations for more details
Pressure loss mode	1000	Only applicable to venturi nozzles. The method for determining the pressure loss over the nozzle 1: Absolute value The pressure loss is taken as an absolute value (as set in parameter 'Pressure Loss Value') 2: Percentage of dP The pressure loss value is taken as a percentage of the differential pressure. The percentage is as set in parameter 'Pressure Loss Value'.
Pressure loss value	1000	Only applicable to venturi nozzles. The pressure loss value either as an absolute value [mbar] or as a percentage [%] of dP.

Temperature settings

Temperature transmitter location	1000	Only applicable to steam Location of the temperature element relative to the nozzle 1: Upstream tapping 2: Downstream tapping 3: Recovered pressure position Downstream at the location where the pressure has fully recovered. If 'Downstream tapping' or 'Recovered pressure position' is selected, a correction of the meter temperature to upstream conditions is applied. Refer to chapter Calculations for more details
Temperature correction	1000	Only applicable to steam This parameter specifies how the temperature must be corrected from downstream / recovered to upstream conditions 1: Isentropic exponent Isentropic expansion using $(1-\kappa)/\kappa$ as the temperature referral exponent 2: Temperature exponent Isentropic expansion using the 'Temperature Exponent' parameter value as the temperature

Temperature exponent	1000	referral exponent [-]. Please note that the 'Temperature Exponent' must be < 0 3: Joule Thomson Isenthalpic expansion using the 'Temperature Exponent' as the Joule Thomson coefficient [°C/bar]. This method is prescribed by ISO5167-1:2003. Only applicable to steam Only used when temperature has to be corrected to upstream conditions and type of temperature correction is either 'Temperature exponent' or 'Joule Thomson'.
----------------------	------	--

Product properties

Dynamic viscosity	Dynamic viscosity [Pa.s] of the selected product. Configurable from the product configuration display.
Isentropic exponent	Isentropic exponent [-] at flowing conditions of the selected product. Configurable from the product configuration display.

dP inputs

Only available if Meter device type is 'Orifice', 'Venturi', 'V-cone', 'Venturi nozzle', 'Long radius nozzle' or 'ISA1932 nozzle'

Up to 3 differential pressure transmitters can be used for dP measurement, required for orifice, venturi, v-cone, venturi nozzle, long radius nozzle and ISA1932 nozzle flow meters.

The flow computer can handle the following type of cell range configurations:

- 1 cell, full range
- 2 cells, low range and high range
- 2 cells, full range
- 3 cells, low, mid and high range
- 3 cells, 1 low range and 2 high range
- 3 cells, full range

The flow computer selects between the configured input cells based on the actual measured value and the failure status of each cell.

The selection logic is described in chapter 'Calculations'.

dP selection



Display → Configuration, Run <x>, Flow meter, dP inputs, dP selection

with <x> the number of the meter run

dP selection type	1000	dP selection type 1: 1 cell full range Cell A - full range 2: 2 cells low / high range Cell A - low range Cell B - high range 3: 2 cells full range Cell A - full range Cell B - full range 4: 3 cells low / mid / high range
-------------------	------	--

		Cell A - low range Cell B - mid range Cell C - high range
		5: 3 cells low / high / high range Cell A - low range Cell B - high range Cell C - high range
		6: 3 cells full range Cell A - full range Cell B - full range Cell C - full range
Switch up percentage	1000	Switch-up value expressed as percentage of span of the lower range. Only used for 2 or 3 cells if more than one dP range is used. Refer to chapter 'Calculations' for more information on its usage. The dP cell selection switches from low range to high range if the reading of the low range cell exceeds this percentage.
Switch down percentage	1000	Switch-down value expressed as percentage of span of the lower range. Only used for 2 or 3 cells if more than one dP range is used. Refer to chapter 'Calculations' for more information on its usage. The dP cell selection switches from high range to low range if the reading of the low range cell gets below this percentage.
dP auto switchback	1000	Determines whether or not to switch back to a dP transmitter when it becomes healthy after a failure. Refer to chapter 'Calculations' for more information on its usage. 0: Disabled 1: Enabled
dP deviation limit	1000	Differential pressure deviation limit [mbar]. Only applicable if dP selection type is '2 cells full range', '3 cells low/high/high' or '3 cells full range'. If the deviation between two dP cells of the same range exceeds this limit, then a dP deviation alarm is generated.

Fail fallback

Fallback type	1000	Determines what to do if the selected dP transmitter fails and there is no other dP transmitter to switch to, or if all applicable dP transmitters fail. 1: Last good value Keep on using the last value that was obtained when the input was still healthy. 2: Fallback value Use the value as specified by parameter 'Fallback value' The fallback value is usually a fixed value and will generally never be changed during the lifetime of the flow computer. 3: Override value Use the value as specified by parameter 'Override value'
Fallback value	1000	Only used if Fallback type is 'Fallback value'. Represents the differential pressure [mbar] that is used when the input fails.

dP input A, B and C



Display → Configuration, Run <x>, Flow meter, dP inputs, dP input A/B/C

with <x> the number of the meter run

Input type

Diff. pressure input type	1000	Type of input for dP cell 2: Analog input 4: HART/Modbus (including multivariable
---------------------------	------	---

transmitters)

5: Custom input

If option 5: Custom is selected then the value [mbar] that is written to tag **Differential pressure A/B/C custom value** will be used. Use this option if the differential pressure value is sent to the flow computer over a Modbus communications link or if you want to apply user-defined calculations to the differential pressure.

Analog input settings

These settings are only applicable if **diff. pressure input type** is 'Analog input', or if **diff. pressure input type** is 'HART/Modbus' with option **HART to analog fallback** enabled

Diff. pressure analog input module	1000	Number of the flow module to which the dP signal is physically connected to. -1: Local module means the module of the meter run itself
Diff. pressure analog input channel	1000	Number of the analog input channel on the selected module to which the dP signal is physically connected.

HART/Modbus settings

These settings are only applicable if **diff. pressure input type** is 'HART/Modbus'

Diff. pressure HART/Modbus internal device nr.	1000	Internal device nr. of the HART/Modbus transmitter as assigned in the configuration software (Flow-Xpress: 'Ports & Devices')
Diff. pressure HART variable value	1000	Determines which of the 4 HART variables provided by the HART transmitter is used. Select the variable that represents the dP value [mbar] . Usually this is the 1st (primary) variable.
Diff. pressure HART/Modbus full scale	1000	Full scale [mbar] of the dP transmitter. Used to calculate the actual percentage of range, which is required for dP selection if multiple dP transmitters with different ranges are used.
Diff. pressure HART/Modbus zero scale	1000	Zero scale [mbar] of the dP transmitter. Used to calculate the actual percentage of range, which is required for dP selection if multiple dP transmitters with different ranges are used.
HART to analog fallback	1000	Only applies for a HART transmitter, where the 4-20 mA signal is provided together with the HART signal. 0: Disabled The 4-20 mA signal will not be used when the HART signal fails. Instead the value corresponding to the 'Fallback type' will be used. 1: Enabled The 4-20 mA signal will be used when the HART signal fails. When both the HART and the mA signal fail the value corresponding to the 'Fallback type' will be used. If multiple HART transmitters are installed within a loop, then the HART to analog fallback option can't be used.

All dP inputs support Modbus multivariable transmitters.

Input frozen alarm

Input frozen time	1000	Maximum time [s] which the input value is allowed to remain unchanged. If the input value hasn't changed during this time, an 'input frozen' alarm is given. Not applicable for input type 'always use override'. Enter 0 to disable this functionality.
-------------------	------	--

Station setup

A station consists of up to 8 runs, each of which can be a local or a remote run. Local runs are part of the station flow computer (and application; f.e. an X/P3 flow computer can contain 3 local runs), while remote runs are separate, single run flow computers, each running its own application, to which the station flow computer communicates through Modbus.



In order to be able to communicate to the remote run flow computer(s), the station flow computer must have a **'Connect to remote run'** Modbus driver configured for every individual remote run (in Flow-Xpress 'Ports and Devices').

On the remote run flow computer(s) the **'Connect to remote station'** Modbus driver has to be enabled (in Flow-Xpress 'Ports and Devices').

The station configuration displays are only available for the following FC types:

- Station /run
- Station / proving / run
- Station only
- Station / proving

Station setup

This display contains the general station configuration settings. Depending on the selections made in this display, specific configuration displays for detailed configuration will be available further down the menu.



Display → Configuration, Station, Station setup

Station data

These data are only used for reporting.

Station tag	600	Station tag (text)
Station ID	600	Station ID (text)

Density

The settings in this section are only available if 'common density input' is enabled.

These settings are replicated from the 'Density setup' display. See the paragraph 'Density setup' for a description of the individual settings.

- Observed density input type
- Observed density input unit type
- Density temperature input type
- Density pressure input type
- Standard density input type
- Standard density input unit type

If an observed density input other than 'none' is selected, then also a **density temperature input** and a **density pressure input** have to be configured.



If an impossible combination of settings is chosen, then a 'Density configuration error' alarm is shown.

Station control setup

From this display the station control functions: flow / pressure control and sampler control can be enabled or disabled.

Depending on the selections made in this display, specific configuration displays for detailed configuration will be available further down the menu.



Display → Configuration, Run <x>, Run control setup with <x> the number of the meter run

Flow / pressure control

Flow / pressure control mode	600	With this setting flow / pressure control (PID control) can be enabled or disabled (none=disabled). For a thorough explanation of this setting refer to paragraph 'Flow / pressure control'.
------------------------------	-----	--

Sampler control

Sampler control	600	With this setting sampler control can be enabled or disabled.
-----------------	-----	---

Meter runs

This display page gives an overview of the meter runs that make up the station.



Display → Configuration, Station, Meter runs

Run <x>

Remote run device nr.	1000	Device nr. of the remote run flow computer as defined in Flow-Xpress 'Ports & devices'. If a valid 'Remote run' device nr. is selected (i.e. if in Flow-Xpress this device nr. has been assigned to a remote run communication device), the run will be designated as 'Remote'. If 'No Device' is selected, the run is either designated as 'Local' or as 'None', depending on the physical flow computer hardware.
Meter run <x> totalizer type	1000	Defines how the station totals and flow rates are calculated. 1: Positive The flow of this run is added to the station totals and rates. This is the default setting. 0: None The flow of this run is not taken into account in the station totals and rates. -1: Negative The flow of this run is subtracted from the station totals and rates. This option can be used for return flows.

System time deviation

These settings are only applicable if the flow computer is communicating to one or more remote run flow computers.

Remote run max. system time deviation	1000	If the system time of a remote run module differs from the system time of the station module by more than this amount [s], then a 'System time out of sync alarm' is generated.
Delay for system time out of sync alarms	1000	System time out of sync alarms only become active after the deviation has been larger than the 'max. deviation' during the delay time [s].

Temperature setup

Temperature transmitters

The flow computer supports the following temperature transmitter inputs:

For each run:

- One or two meter temperature transmitters (A and B)
- One density temperature transmitter

For the station:

- One density temperature transmitter

For each prover (A/B):

- One prover inlet temperature transmitter
- One prover outlet temperature transmitter
- One prover rod temperature transmitter (for Calibron / Flow MD small volume prover)
- One prover density transmitter

Auxiliary inputs:

- Two auxiliary temperature transmitters (1 and 2)

Meter temperature transmitters

Either a single temperature transmitter or dual temperature transmitters can be used. In case of dual transmitters there are several schemes for determining the in-use meter temperature (duty / standby or average) and a deviation check is done between the two temperature values.

Density temperature transmitters

Density temperature transmitters are used in combination with an observed (live) density (e.g. a densitometer) and measure the temperature at the point where the density is measured.

In case of an observed (live) density on a run, a density temperature transmitter is optional. If no density temperature transmitter is configured, the flow computer uses the meter temperature.

In case of a station observed (live) density, the use of a density temperature transmitter is obligatory.

In case of a prover observed (live) density, a density temperature transmitter is optional. If no prover density temperature transmitter is configured, the flow computer uses the prover temperature (which is the average of the prover inlet temperature and the prover outlet temperature).

Prover temperature transmitters

If both prover inlet and outlet temperatures are configured, the in-use prover temperature is calculated as the average of both. If only one of them is configured, the in-use prover temperature equals this one. If none is configured, the flow computer uses the meter temperature.

Auxiliary temperature transmitters

Two auxiliary temperature transmitters can be defined (e.g. a station temperature). These are for informational purposes only, or can be used in custom calculations.



Display → Configuration, Run <x>, Temperature (, Meter temperature A/B)

Display → Configuration, Run <x>, Temperature, Density temperature

Display → Configuration, Station, Temperature

Display → Configuration, Proving (, Prover A/B), Temperature (, Prover inlet temperature)

Display → Configuration, Proving (, Prover A/B), Temperature (, Prover outlet temperature)

Display → Configuration, Proving (, Prover A/B), Temperature, Prover rod temperature

Display → Configuration, Proving (, Prover A/B), Temperature, Prover density temperature

Display → Configuration, Auxiliary inputs, Auxiliary temperature 1/2

with <x> the number of the meter run

For each temperature transmitter the following settings are available:

Input type

Input type	1000	Type of input
		1: Always use override
		2: Analog input
		3: PT100 input
		4: HART/Modbus
		5: Custom input
		The value [°C] that is written to the corresponding custom input tag (e.g. Meter temperature custom value) will be used. Use this option if the temperature value is sent to the flow computer over a Modbus communications link or if you want to apply user-defined calculations to the temperature.
		6: Smart flow meter (meter temperature only)
		8: Prover remote IO server (prover temperatures only)
		The temperature is read from a remote flow computer that has been configured as 'Prover IO server'. See paragraph Proving, Prover setup, Local / remote prover IO for more details.

Analog / PT100 input settings

These settings are only applicable if the **temperature input type** is 'Analog input' or 'PT100 input', or if the **temperature input type** is 'HART/Modbus' with **HART to analog fallback** enabled.

Analog / PT100 input module	1000	Number of the flow module to which the signal is physically connected. -1: Local module means the module of the meter run itself
Analog / PT100 input channel	1000	Number of the analog / PT100 input channel on the selected module to which the signal is physically connected.

HART/Modbus settings

These settings are only applicable if the **temperature input type** is 'HART/Modbus'.

HART/Modbus internal device nr.	1000	Internal device nr. of the HART/Modbus transmitter as assigned in the configuration software (Flow-Xpress: 'Ports & Devices').
HART variable	1000	Determines which of the 4 HART variables provided by the HART transmitter is used. Select the variable that represents the temperature . Usually this is the 1st (primary) variable.
HART to analog fallback	1000	Only applies for a single HART transmitter, where the 4-20 mA signal is provided together with the HART signal. 0: Disabled The 4-20 mA signal will not be used when the HART signal fails. Instead the value corresponding with the 'Fallback type' will be used. 1: Enabled The 4-20 mA signal will be used when the HART signal fails. If both the HART and the mA signal fail the value corresponding with the Fallback type will be used. If multiple HART transmitters are installed within a loop, then the HART to analog fallback option can't be used.

Modbus multivariable transmitters are only supported for meter temperature A/B.

Smart meter settings

Only applicable if the **temperature input type** is 'Smart meter'.

Smart meter internal device nr.	1000	Device nr. of the smart meter as assigned in the configuration software (Flow-Xpress, section 'Ports & Devices')
---------------------------------	------	--

Fail fallback

Fallback type	1000	Determines what to do if the input fails. 1: Last good value Keep on using the last value that was obtained when the input was still healthy. 2: Fallback value Use the value as specified by parameter 'Fallback value' The fallback value is usually a fixed value and will generally never be changed during the lifetime of the flow computer. 3: Override value Use the value as specified by parameter 'Override value'
Fallback value	1000	Only used if Fallback type is 'Fallback value'. Represents the temperature [°C] that is used when the input fails.

Input frozen alarm

Input frozen time	1000	Maximum time [s] which the input value is allowed to remain unchanged. If the input value hasn't changed during this time, an 'input frozen' alarm is given. Not applicable for input type 'always use override'. Enter 0 to disable this functionality.
-------------------	------	--

Temperature transmitter selection

Only applicable in case of dual meter temperature transmitters



Display → Configuration, Run <x>, Temperature, Meter temperature

with <x> the number of the meter run

Transmitter selection

Dual transmitter mode	1000	Determines how the in-use meter temperature is calculated from both transmitter values 1: Auto transmitter A Transmitter value A is used when it is healthy and not out of service. Transmitter value B is used when transmitter A fails, or is out of service, while transmitter B is healthy and not out of service. If both transmitters fail or are out of service, the value according to the Fallback type is used. 2: Auto transmitter B Transmitter value B is used when it is healthy and not out of service. Transmitter value A is used when transmitter B fails, or is out of service, while transmitter A is healthy and not out of service. If both transmitters fail or are out of service, the value according to the Fallback type is used. 3: Average If both transmitters are healthy and not out of service, the average of both values is used. If one transmitter fails or is out of service, while the other is healthy and not out of service, the other transmitter is used. If both transmitters fail or are out of service, the value according to the Fallback type is used.
-----------------------	------	---

Transmitter deviation

Meter temperature deviation limit	1000	Temperature deviation limit [°C]. If the deviation between two temperature transmitters exceeds this limit, then a temperature deviation alarm is generated.
Temperature deviation fallback mode	1000	Determines what happens in case of a temperature deviation alarm. 0: None A deviation alarm is given, but the original input value remains in use. 1: Transmitter failure The deviation alarm is treated as a transmitter failure: depending on the fallback type either the last good, fallback or override value is used. 2: Use transmitter A value 3: Use transmitter B value

Pressure setup

Pressure transmitters

The flow computer supports the following pressure transmitter inputs:

For each run:

- One or two meter pressure transmitters (A and B)
- One density pressure transmitter

For the station:

- One density pressure transmitter

For each prover (A/B):

- One prover inlet pressure transmitter
- One prover outlet pressure transmitter
- One prover plenum pressure transmitter (for Brooks compact prover)
- One prover density transmitter

Auxiliary inputs:

- Two auxiliary pressure transmitters (1 and 2)

Meter pressure transmitters

Either a single pressure transmitter or dual pressure transmitters can be used. In case of dual transmitters there are several schemes for determining the in-use meter pressure (duty / standby or average) and a deviation check is done between the two pressure values.

Density pressure transmitters

Density pressure transmitters are used in combination with an observed (live) density (e.g. a densitometer) and measure the pressure at the point where the density is measured.

In case of an observed (live) density on a run, a density pressure transmitter is optional. If no density pressure transmitter is configured, the flow computer uses the meter pressure.

In case of a station observed (live) density, the use of a density pressure transmitter is obligatory.

In case of a prover observed (live) density, a density pressure transmitter is optional. If no prover density pressure transmitter is configured, the flow computer uses the prover pressure (which is the average of the prover inlet pressure and the prover outlet pressure).

Prover pressure transmitters

If both prover inlet and outlet pressures are configured, the in-use prover pressure is calculated as the average of both. If only one of them is configured, the in-use prover pressure equals this one. If none is configured, the flow computer uses the meter pressure.

Auxiliary pressure transmitters

Two auxiliary pressure transmitters can be defined (e.g. a station pressure). These are for informational purposes only, or can be used in custom calculations.



Display → Configuration, Run <x>, Pressure (, Meter pressure A/B)

Display → Configuration, Run <x>, Pressure, Density pressure

Display → Configuration, Station, Pressure

Display → Configuration, Proving (, Prover A/B), Pressure (, Prover inlet pressure)

Display → Configuration, Proving (, Prover A/B), Pressure (, Prover outlet pressure)

Display → Configuration, Proving (, Prover A/B), Pressure, Prover rod pressure

Display → Configuration, Proving (, Prover A/B), Pressure, Prover density pressure

Display → Configuration, Auxiliary inputs, Auxiliary pressure 1/2 with <x> the number of the meter run

For each pressure transmitter the following settings are available:

Input type

Input type	1000	Type of input
		1: Always use override
		2: Analog input
		4: HART/Modbus
		5: Custom input
		The value ([bara] or [barg]), depending on the selected pressure input units) that is written to the corresponding custom input tag (e.g. Meter pressure custom value) will be used. Use this option if the pressure value is sent to the flow computer over a Modbus communications link or if you want to apply user-defined calculations to the pressure.6: Smart flow meter (meter pressure only)
		8: Prover remote IO server (prover pressures only)
		The pressure is read from a remote flow computer that has been configured as 'Prover IO server' module. See paragraph Proving, Prover setup, Local / remote prover IO for more details.
Input units	1000	1: Absolute
		The input value is an absolute pressure
		2: Gauge
		The input value is a gauge pressure (i.e. relative to the atmospheric pressure)

Analog input settings

These settings are only applicable if the **pressure input type** is 'Analog input', or if the **pressure input type** is 'HART/Modbus' with **HART to analog fallback** enabled.

input module	1000	Number of the flow module to which the signal is physically connected.
		-1: Local module means the module of the meter run itself
Analog input	1000	Number of the analog input channel on the selected

channel module to which the signal is physically connected.

HART/Modbus settings

These settings are only applicable if the **pressure input type** is 'HART/Modbus'.

HART/Modbus internal device nr.	1000	Internal device nr. of the HART/Modbus transmitter as assigned in the configuration software (Flow-Xpress: 'Ports & Devices')
HART variable	1000	Determines which of the 4 HART variables provided by the HART transmitter is used. Select the variable that represents the pressure . Usually this is the 1st (primary) variable.
HART to analog fallback	1000	Only applies for a single HART transmitter, where the 4-20 mA signal is provided together with the HART signal. 0: Disabled The 4-20 mA signal will not be used when the HART signal fails. Instead the value corresponding with the 'Fallback type' will be used. 1: Enabled The 4-20 mA signal will be used when the HART signal fails. If both the HART and the mA signal fail the value corresponding with the Fallback type will be used. If multiple HART transmitters are installed within a loop, then the HART to analog fallback option can't be used.

Modbus multivariable transmitters are only supported for meter pressure A/B.

Smart meter settings

Only applicable if the **pressure input type** is 'Smart meter'.

Smart meter internal device nr.	1000	Device nr. of the smart meter as assigned in the configuration software (Flow-Xpress, section 'Ports & Devices')
---------------------------------	------	--

Fail fallback

Fallback type	1000	Determines what to do if the input fails. 1: Last good value Keep on using the last value that was obtained when the input was still healthy. 2: Fallback value Use the value as specified by parameter 'Fallback value' The fallback value is usually a fixed value and will generally never be changed during the lifetime of the flow computer. 3: Override value Use the value as specified by parameter 'Override value'
Fallback value	1000	Only used if Fallback type is 'Fallback value'. Represents the pressure ([bar(a)] or [bar(g)], depending on the selected input units) that is used when the input fails.

Input frozen alarm

Input frozen time	1000	Maximum time [s] which the input value is allowed to remain unchanged. If the input value hasn't changed during this time, an 'input frozen' alarm is given. Not applicable for input type 'always use override'. Enter 0 to disable this functionality.
-------------------	------	--

Pressure transmitter selection

Only applicable in case of dual meter pressure transmitters



Display → Configuration, Run <x>, Pressure, Meter pressure

with <x> the number of the meter run

Transmitter selection

Dual transmitter mode	1000	Determines how the in-use meter pressure is calculated from both transmitter values 1: Auto transmitter A Transmitter value A is used when it is healthy and not out of service. Transmitter value B is used when transmitter A fails, or is out of service, while transmitter B is healthy and not out of service. If both transmitters fail or are out of service, the value according to the Fallback type is used. 2: Auto transmitter B Transmitter value B is used when it is healthy and not out of service. Transmitter value A is used when transmitter B fails, or is out of service, while transmitter A is healthy and not out of service. If both transmitters fail or are out of service, the value according to the Fallback type is used. 3: Average If both transmitters are healthy and not out of service, the average of both values is used. If one transmitter fails or is out of service, while the other is healthy and not out of service, the other transmitter is used. If both transmitters fail or are out of service, the value according to the Fallback type is used.
-----------------------	------	--

Transmitter deviation

Meter pressure deviation limit	1000	Pressure deviation limit [bar]. If the deviation between two pressure transmitters exceeds this limit, then a pressure deviation alarm is generated.
Pressure deviation fallback mode	1000	Determines what happens in case of a pressure deviation alarm. 0: None A deviation alarm is given, but the original input value remains in use. 1: Transmitter failure The deviation alarm is treated as a transmitter failure: depending on the fallback type either the last good, fallback or override value is used. 2: Use transmitter A value 3: Use transmitter B value

Density setup

The flow computer supports the following density inputs:

For each run:

- One or two densitometers or one analog / HART / smart meter observed density input
- One analog / HART standard density input

For the station:

- One or two densitometers or one analog / HART observed density input
- One analog / HART standard density input

For each prover (A/B):

- One densitometer or one analog / HART observed density input

Auxiliary inputs:

- Two densitometers

If the flow computer is used for 2 or more meter runs, the density input can be either a common input for all the meter runs or a separate input for each meter run. E.g. a densitometer can be installed in the header of the metering station in which case one and the same density measurement is used for all meter runs, or separate densitometers can be installed in each run.



Whether the density setup is on station or meter run level is controlled by parameter **Common density input**, which is accessible through display Configuration, Overall setup, Common settings.

See paragraph 'common settings' for more details.



Display → Configuration, Run <x>, Density (, Density setup)

Display → Configuration, Station, Density (, Density setup)

Display → Configuration, Proving, Density (, Density setup)

Display → Configuration, Auxiliary inputs, Setup

with <x> the number of the meter run

Observed density input type	1000	Defines how the observed density (density at densitometer conditions) is determined 0: None There is no observed density input 1: Always use override Use this option if a fixed value is used for the observed density 2: Analog input 4: HART/Modbus 5: Custom input The value [kg/m3] that is written to tag Observed density custom value will be used as the observed density. Use this option if the
-----------------------------	------	---

		observed density value is sent to the flow computer over a Modbus communications link or if you want to apply user-defined calculations to the observed density value.
		6: One densitometer The observed density is read from a single densitometer.
		7: Two densitometers The observed density is provided by two (redundant) densitometers. The observed density of the selected densitometer is used.
		8: Smart flow meter The observed density [kg/m3] is read from the smart (Coriolis) flow meter. Only applicable for run observed density input.
		9: Prover remote IO server (prover density only) The density is read from a remote flow computer that has been configured as 'Prover IO server' module. See paragraph Proving, Prover setup, Local / remote prover IO for more details.
		In case of a remote run with Common density input enabled the observed density is read from the station flow computer.
		If a station observed density input other than 'none' is selected, then also a station density temperature input and a density pressure input have to be configured.
		In case of a run, prover or auxiliary observed density input the use of separate density temperature and density pressure inputs are optional. See paragraphs 'Temperature setup' and 'pressure setup' for more information.
Density temperature input type	1000	Type of input for the density temperature (temperature at the density meter). 0: None 1: Always use override 2: Analog input 3: PT100 input 4: HART/Modbus 5: Custom input If this option is selected then the value [°C] that is written to tag Density temperature custom value is used. Use this option if the temperature value is sent to the flow computer over a Modbus communications link or if you want to apply user-defined calculations to the density temperature.
		In case of a remote run FC with Common density input enabled the density temperature is read from the station flow computer.
Density pressure input type	1000	Type of input for the density pressure (pressure at the density meter). 0: None 1: Always use override 2: Analog input 4: HART/Modbus 5: Custom input If this option is selected then the value [bar] that is written to tag Density pressure custom value is used. Use this option if the pressure value is sent to the flow computer over a Modbus communications link or if you want to apply user-defined calculations to the density pressure.
		In case of a remote run FC with Common density input enabled the density pressure is read from the station flow computer.
Standard density input type	1000	Defines how the standard density is determined 0: Calculated Not applicable to ethylene. For all other products except propylene, water / steam and asphalt the selection 'Calculated' requires an observed density to be available, because the standard density is calculated from the observed density value. In case of propylene,

water / steam and asphalt the standard density is calculated from the base temperature and base pressure only, so an observed density value is not needed.

1: From product table
Use this option if a fixed value is used for the standard density. This fixed value is retrieved from the product table.

2: Analog input

4: HART/Modbus

5: Custom input
The value that is written to tag **Standard density custom value** will be used as the standard density. Use this option if the standard density value is sent to the flow computer over a Modbus communications link or if you want to apply user-defined calculations to the standard density value.

In case of a remote run FC with **Common density input** enabled the standard density is read from the station flow computer.

HART/Modbus internal device nr.	1000	Internal device nr. of the HART/Modbus transmitter as assigned in the configuration software (Flow-Xpress: 'Ports & Devices')
HART variable	1000	Determines which of the 4 HART variables provided by the HART transmitter is used. Select the variable that represents the observed density . Usually this is the 1st (primary) variable.
HART to analog fallback	1000	Only applies for a single HART transmitter, where the 4-20 mA signal is provided together with the HART signal. 0: Disabled The 4-20 mA signal will not be used when the HART signal fails. Instead the value corresponding with the 'Fallback type' will be used. 1: Enabled The 4-20 mA signal will be used when the HART signal fails. If both the HART and the mA signal fail the value corresponding with the Fallback type will be used. If multiple HART transmitters are installed within a loop, then the HART to analog fallback option can't be used.



If an impossible combination of settings is chosen, then a 'Density configuration error' alarm is shown.

Observed density



Display → Configuration, Run <x>, Density, Observed density

Display → Configuration, Station, Density, Observed density

Display → Configuration, Proving, Density, Observed density

with <x> the number of the meter run

Input type and units

Observed density input type	1000	See the description in the previous paragraph
Input unit type	1000	Input unit for the observed density input 1: Relative density The input signal represents the relative density / specific gravity 2: API gravity The input signal represents API gravity 3: Density [kg/m ³] The input signal represents the density in kg/m ³ . Typically used for densitometers

Analog input settings

These settings are only applicable if the **observed density input type** is 'Analog input', or if the **observed density input type** is 'HART/Modbus' with **HART to analog fallback** enabled.

Analog input module	1000	Number of the flow module to which the signal is physically connected. -1: Local module means the module of the meter run itself
Analog input channel	1000	Number of the analog input channel on the selected module to which the signal is physically connected.

HART/Modbus settings

These settings are only applicable if the **observed density input type** is 'HART/Modbus'.

Smart meter settings

These settings are only applicable if the **observed density input type** is 'Smart meter'.

Smart meter internal device nr.	1000	Internal device nr. of the smart meter as assigned in the configuration software (Flow-Xpress: 'Ports & Devices')
---------------------------------	------	---

Fail fallback

Fallback type	1000	Determines what to do in case the input fails. 1: Last good value Keep on using the last value that was obtained when the input was still healthy. 2: Fallback value Use the value as specified by parameter 'Fallback value' The fallback value is usually a fixed value and will generally never be changed during the lifetime of the flow computer. 3: Override value Use the value as specified by parameter 'Override value'
Fallback value	1000	Only used when Fallback type is 'Fallback value'. Represents the observed density to be used when the input fails. The unit depends on the selected observed density input unit type (relative density, API gravity, density)
High fail limit	1000	High fail limit for the input value. Above this value the input value is considered to be faulty. The unit depends on the selected observed density input unit type (relative density, API gravity, density)
Low fail limit	1000	Low fail limit for the input value. Below this value the input value is considered to be faulty. The unit depends on the selected observed density input unit type (relative density, API gravity, density)
Failure delay	1000	Optional delay time [s] on all observed density / densitometer failure alarms (if applicable): <ul style="list-style-type: none"> Density limit fail Analog input low fail Analog input high fail HART/Modbus input fail Custom input fail Densitometer input fail Densitometer calculation fail Densitometer communication fail (Anton Paar) Densitometer analog input fail (Anton Paar) Densitometer measurement fail (Anton Paar) A failure alarm is generated if the failure condition lasts longer than this delay time. During this delay time the last good (measured or calculated) density value is used. After the delay time the alarm becomes active and the

value configured as 'observed density fallback type' is used.
 If a failure delay is used in combination with a dual densitometer setup, this setting also delays densitometer switching in case of an alarm on the in-use densitometer.
 Enter 0 to disable this feature.

Input frozen alarm

Input frozen time	1000	Maximum time [s] which the input value is allowed to remain unchanged. If the input value hasn't changed during this time, an 'input frozen' alarm is given. Not applicable for input type 'always use override'. Enter 0 to disable this functionality.
-------------------	------	--

Coriolis density correction

The density read from a Coriolis flow meter can be corrected for pressure influences by applying the following formula:

$$\rho_{cor} = \rho \times \left(1 + [A + B \times \rho + C \times \rho^2] \times (P - P_{ref}) \right) + D$$

Where:

- ρ_{corr} : Corrected observed density
- ρ : Uncorrected observed density
- P: Pressure at the density meter
- P_{ref} : Reference pressure
- A, B, C, D : Correction coefficients

This correction is applicable if **Observed density input type** is set to 'Analog input', 'HART/Modbus', 'Smart flow meter' or 'Custom input'.

Coriolis density correction	1000	Enables or disables the density correction for Coriolis meters. 0: Disabled 1: Enabled
Coriolis density correction ref. pressure	1000	Reference pressure [bar(a)] to be used for the density correction
Coriolis density correction coefficients A, B, C, D	1000	Coefficients A, B, C and D to be used in the density correction formula.

Densitometer setup

The following display is only available if **Observed density input type** is set to 'One densitometer' or 'Two densitometers'



Display → Configuration, Run <x>, Density, Densitometer, Densitometer setup

Display → Configuration, Station, Density, Densitometer, Densitometer setup

Display → Configuration, Proving, Density, Densitometer, Densitometer setup

Display → Configuration, Auxiliary inputs, Auxiliary densitometer <y>, Densitometer setup

with <x> the number of the meter run and <y> the number of the auxiliary densitometer (1/2)

Densitometer type	1000	Densitometer A/B device type. 1: Solartron 2: Sarasota 3: UGC 4: Anton Paar In case of an Anton Paar densitometer, the corresponding communication protocol (HART or Modbus) has to be configured in Flow-Xpress, Ports and Devices.
Densitometer units	1000	Densitometer units. 1: kg/m3 2: g/cc 3: lb/ft3
Densitometer select mode	500	Only applicable if Observed density input type is set to 'Two densitometers'. Densitometer selection mode. 1: Auto-A Densitometer B only used when densitometer A fails and densitometer B is healthy. Densitometer A is used in all other cases. 2: Auto-B Densitometer A is only used when densitometer B fails and densitometer A is healthy. Densitometer B is used in all other cases. 3: Manual-A Always use densitometer A irrespective of its failure status 4: Manual-B Always use densitometer B irrespective of its failure status

Time period A/B

Time period settings of densitometer A /B. Time period B settings are only applicable if **Observed density input type** is set to 'Two densitometers'.

Input module	1000	Flow-X module to which the densitometer A/B signal is connected to.
Input number	1000	Defines the time period input of the Flow-X module for densitometer A/B. Each module has a maximum of 4 time period inputs. A time period input can be connected to a physical digital channel on display: IO, Module <x>, Configuration, Digital IO assign. See paragraph 'Digital IO assign' for more details.
Input averaging	1000	Enables / disables input averaging. 0: Disabled The density is directly calculated from the input signal 1: Enabled The density is calculated from the moving averaged input signal
Averaging cycles	1000	Number of flow computer cycles (by default 1 cycle = 500 ms) for averaging the densitometer signal

Deviation limit

Only applicable if **Observed density input type** is set to 'Two densitometers'.

Densitometer A/B deviation limit	1000	If the deviation between the density from both densitometers exceeds this limit [kg/m3], then a 'Densitometer A/B deviation limit exceeded' alarm is generated.
----------------------------------	------	---

Density correction factor

Use product	1000	Defines whether a separate density correction
-------------	------	---

DCF		factor (DCF) is used for each product (density correction factors to be configured at product setup) or a separate density correction factor for each densitometer (uses the density correction factor(s) specified on this display). 0: Disabled Separate DCF for each densitometer, one value for all products 1: Enabled Separate DCF for each product, one value for all densitometers
DCF nominal value	1000	Only applicable if Use product DCF disabled. Nominal density correction factor (DCF). The incoming observed density (analog / HART / Modbus / densitometer / custom / override value) is multiplied by this factor.
Densitometer A/B nominal correction factor	1000	Only applicable in case of dual densitometers with Use product DCF disabled. Separate density correction factor (DCF) for densitometer A/B. The density as measured by densitometer A/B is multiplied by this factor.
Aux. densitometer product selection	1000	Only applicable for auxiliary densitometers with Use product DCF enabled. Defines the product that is used to look up the product DCF. -1: Custom Uses the product number that is written to the tag Aux. densitometer 1/2 custom product number . 0: Station Uses the in-use product number of the station x: Run x Uses the in-use product number of run <x>

Input frozen alarm

Input frozen time	1000	Maximum time [s] which the input value is allowed to remain unchanged. If the input value hasn't changed during this time, an 'input frozen' alarm is given. Enter 0 to disable this functionality.
-------------------	------	---

Solartron / Sarasota / UGC densitometer setup

The densitometer constants are device-specific and can be defined on the following display.

-  Display → Configuration, Run <x>, Density, Densitometer, Densitometer A / B constants
 - Display → Configuration, Station, Density, Densitometer, Densitometer A / B constants
 - Display → Configuration, Proving, Density, Densitometer, Densitometer A / B constants
 - Display → Configuration, Auxiliary inputs, Auxiliary densitometer <y>, Densitometer constants
- with <x> the number of the meter run and <y> the number of the auxiliary densitometer (1/2)

All densitometer constants are at security level 1000. Refer to section calculations for the meaning of these settings.

Anton Paar densitometer setup

Two types of Anton Paar densitometers are supported: conventional densitometers with a frequency output and densitometers communicating to the flow computer through HART or Modbus serial communication.



Display → Configuration, Run <x>, Density, Densitometer, Densitometer A / B constants

Display → Configuration, Station, Density, Densitometer, Densitometer A / B constants

Display → Configuration, Proving, Density, Densitometer, Densitometer A / B constants

Display → Configuration, Auxiliary inputs, Auxiliary densitometer <y>, Densitometer constants

with <x> the number of the meter run and <y> the number of the auxiliary densitometer (1/2)

Densitometer input type	1000	Defines the signal type that is used: 1: Time period Uses the (conventional) time period / frequency signal 2: HART/Modbus Uses the HART or Modbus input that is configured in Flow-Xpress: 'Ports & Devices' 3: Analog Uses the analog (4-20 mA) signal
-------------------------	------	--

Analog input settings

These settings are only applicable if the **densitometer input type** is set to 'Analog input', or if the **densitometer input type** is 'HART/Modbus' with **HART to analog fallback** enabled.

Analog input module	1000	Number of the flow module to which the signal is physically connected. -1: Local module means the module of the meter run itself
Analog input channel	1000	Number of the analog input channel on the selected module to which the signal is physically connected.

HART/Modbus settings

These settings are only applicable if the **densitometer input type** is 'HART/Modbus'

HART/Modbus internal device nr.	1000	Internal device nr. of the HART/Modbus transmitter as assigned in the configuration software (Flow-Xpress: 'Ports & Devices')
HART to analog fallback	1000	Only applies for a single HART transmitter, where the 4-20 mA signal is provided together with the HART signal. 0: Disabled The 4-20 mA signal will not be used when the HART signal fails. Instead the value corresponding with the 'Fallback type' will be used. 1: Enabled The 4-20 mA signal will be used when the HART signal fails. If both the HART and the mA signal fail the value corresponding with the Fallback type will be used. If multiple HART transmitters are installed within a loop, then the HART to analog fallback option can't be used.

Densitometer constants

Only applicable if the **densitometer input type** is 'Time period'. Constants for calculation of the density from the time period signal.

All densitometer constants are at security level 1000.
Refer to section calculations for the meaning of these settings.

Standard density



Display → Configuration, Run <x>, Density, Standard density

Display → Configuration, Station, Density, Standard density
with <x> the number of the meter run

Input type and units

Standard density input type	1000	See the description above, in the paragraph 'Density setup'
Input unit type	1000	Input unit for the standard density input 1: Relative density [-] 2: API gravity [°API] 3: Density [kg/sm3]

Analog input settings

These settings are only applicable if the **standard density input type** is set to 'Analog input', or if the **standard density input type** is 'HART/Modbus' with **HART to analog fallback** enabled.

Analog input module	1000	Number of the flow module to which the signal is physically connected. -1: Local module means the module of the meter run itself
Analog input channel	1000	Number of the analog input channel on the selected module to which the signal is physically connected.

HART/Modbus settings

These settings are only applicable if the **standard density input type** is 'Analog input', or if the **standard density input type** is 'HART/Modbus' with **HART to analog fallback** enabled.

HART/Modbus internal device nr.	1000	Internal device nr. of the HART/Modbus transmitter as assigned in the configuration software (Flow-Xpress: 'Ports & Devices')
HART variable	1000	Determines which of the 4 HART variables provided by the HART transmitter is used. Select the variable that represents the standard density . Usually this is the 1st (primary) variable.
HART to analog fallback	1000	Only applies for a single HART transmitter, where the 4-20 mA signal is provided together with the HART signal. 0: Disabled The 4-20 mA signal will not be used when the HART signal fails. Instead the value corresponding with the 'Fallback type' will be used. 1: Enabled The 4-20 mA signal will be used when the HART signal fails. When both the HART and the mA signal fail the value corresponding with the 'Fallback type' will be used. If multiple HART transmitters are installed within a loop, then the HART to analog fallback option can't be used.

Fail fallback

Fallback type	1000	Determines what to do in case the input fails. 1: Last good value Keep on using the last value that was obtained when the input was still healthy. 2: Fallback value Use the value as specified by parameter 'Fallback value'
---------------	------	---

Fallback value	1000	The fallback value is usually a fixed value and will generally never be changed during the lifetime of the flow computer. 3: Override value Use the value as specified by parameter 'Override value'
High fail limit	1000	Only used when Fallback type is 'Fallback value'. Represents the value to be used when the input fails. The unit depends on the standard density input unit type . High fail limit for the input value. Above this value the input value is considered to be faulty. The unit depends on the selected standard density input unit type (relative density, API gravity, density)
Low fail limit	1000	Low fail limit for the input value. Below this value the input value is considered to be faulty. The unit depends on the standard density input unit type (relative density, API gravity, density)
Failure delay	1000	Optional delay time [s] on all standard density failure alarms (if applicable): • Standard density limit fail • Analog input low fail • Analog input high fail • HART/Modbus input fail • Custom input fail An alarm is generated if the failure condition lasts longer than this delay time. During the delay time the last good standard density value is used. After the delay time the alarm becomes active and the value configured as 'standard density fallback type' is used. Enter 0 to disable this feature.

Input frozen alarm

Input frozen time	1000	Maximum time [s] which the input value is allowed to remain unchanged. If the input value hasn't changed during this time, an 'input frozen' alarm is given. Only applicable in case of a life (not calculated) or custom input value. Not applicable for input type 'always use override'. Enter 0 to disable this functionality.
-------------------	------	--

BS&W setup

The flow computer supports the following BS&W inputs:

For each run:

- One analog / HART BS&W input

For the station:

- One analog / HART BS&W input

The BS&W value is used for the calculation of the net standard volume flow rate.

If the flow computer is used for 2 or more meter runs, the BS&W input can be either a common input for all the meter runs or a separate input for each meter run. E.g. a BS&W transmitter can be installed in the header of the metering station in which case one and the same BS&W measurement is used for all meter runs, or separate BS&W transmitters can be installed in each run.



Whether the BS&W setup is on station or meter run level is controlled by parameter **Common BS&W input**, which is accessible through display Configuration, Overall setup, Common settings.

See paragraph 'common settings' for more details.



Display → Configuration, Run <x>, BSW

Display → Configuration, Station, BSW

with <x> the number of the meter run

Input type

Input type	1000	Type of input
		0: None
		1: Always use override
		2: Analog input
		4: HART
		5: Custom input
		The value [%vol] that is written to the BS&W custom value will be used. Use this option if the BS&W value is sent to the flow computer over a Modbus communications link or if you want to apply user-defined calculations to the BS&W.
		In case of a remote run FC with Common BS&W input enabled the BS&W value is read from the station flow computer.

Analog input settings

These settings are only applicable if the **BS&W input type** is 'Analog input', or if the **BS&W input type** is 'HART/Modbus' with **HART to analog fallback** enabled.

Analog input module	1000	Number of the flow module to which the signal is physically connected.
		-1: Local module means the module of the meter run itself
Analog input channel	1000	Number of the analog input channel on the selected module to which the signal is physically connected.

HART/Modbus settings

These settings are only applicable if the **BS&W input type** is 'HART/Modbus'.

HART/Modbus internal device nr.	1000	Internal device nr. of the HART/Modbus transmitter as assigned in the configuration software (Flow-Xpress: 'Ports & Devices')
HART variable	1000	Determines which of the 4 HART variables provided by the HART transmitter is used. Select the variable that represents the BS&W . Usually this is the 1st (primary) variable.
HART to analog fallback	1000	Only applies for a single HART transmitter, where the 4-20 mA signal is provided together with the HART signal. 0: Disabled The 4-20 mA signal will not be used when the HART signal fails. Instead the value corresponding with the 'Fallback type' will be used. 1: Enabled The 4-20 mA signal will be used when the HART signal fails. When both the HART and the mA signal fail the value corresponding with the 'Fallback type' will be used. If multiple HART transmitters are installed within a loop, then the HART to analog fallback option can't be used.

Fail fallback

Fallback type	1000	Determines what to do in case the input fails.
		1: Last good value Keep on using the last value that was obtained when the input was still healthy.
		2: Fallback value Use the value as specified by parameter 'Fallback value' The fallback value is usually a fixed value and will generally never be changed during the lifetime of the flow computer.
		3: Override value Use the value as specified by parameter 'Override value'
Fallback value	1000	Only used when Fallback type is 'Fallback value'.

Input frozen alarm

Input frozen time	1000	Maximum time [s] which the input value is allowed to remain unchanged. If the input value hasn't changed during this time, an 'input frozen' alarm is given. Enter 0 to disable this functionality.
-------------------	------	---

Viscosity setup

The flow computer supports the following viscosity inputs:

For each run:

- One analog / HART viscosity input

For the station:

- One analog / HART viscosity input

The viscosity value is used to correct for the influence of the viscosity on turbine and PD flow meters. Refer to section Configuration\...\Flow meter\Viscosity correction for more details.

If the flow computer is used for 2 or more meter runs, the viscosity input can be either a common input for all the meter runs or a separate input for each meter run. E.g. a viscosity transmitter can be installed in the header of the metering station in which case one and the same viscosity measurement is used for all meter runs, or separate viscosity transmitters can be installed in each run.



Whether the BS&W setup is on station or meter run level is controlled by parameter **Common viscosity input**, which is accessible through display Configuration, Overall setup, Common settings.

See paragraph 'common settings' for more details.



Display → Configuration, Run <x>, Viscosity

Display → Configuration, Station, Viscosity

with <x> the number of the meter run

Input type

Input type	1000	Type of input
		0: None
		1: Always use override
		2: Analog input
		4: HART/Modbus
		5: Custom input
		The value [Pa.s] that is written to the viscosity custom value will be used. Use this option if the viscosity value is sent to the flow computer over a Modbus communications link or if you want to apply user-defined calculations to the viscosity.
		7: Calculated (ASTM-D341-09)
		The viscosity is calculated according to ASTM D341-09.
		In case of a remote run FC with Common viscosity input enabled the viscosity is read from the station flow computer.

Analog input settings

These settings are only applicable if the **viscosity input type** is 'Analog input', or if the **viscosity input type** is 'HART/Modbus' with **HART to analog fallback** enabled.

Analog input module	1000	Number of the flow module to which the signal is physically connected. -1: Local module means the module of the meter run itself
Analog input channel	1000	Number of the analog input channel on the selected module to which the signal is physically connected.

HART/Modbus settings

These settings are only applicable if the **viscosity input type** is 'HART/Modbus'.

HART/Modbus internal device nr.	1000	Internal device nr. of the HART/Modbus transmitter as assigned in the configuration software (Flow-Xpress: 'Ports & Devices')
--	------	---

HART variable	1000	Determines which of the 4 HART variables provided by the HART transmitter is used. Select the variable that represents the viscosity . Usually this is the 1st (primary) variable.
----------------------	------	---

HART to analog fallback	1000	Only applies for a single HART transmitter, where the 4-20 mA signal is provided together with the HART signal. 0: Disabled The 4-20 mA signal will not be used when the HART signal fails. Instead the value corresponding with the 'Fallback type' will be used.
--------------------------------	------	--

1: Enabled	The 4-20 mA signal will be used when the HART signal fails. When both the HART and the mA signal fail the value corresponding with the 'Fallback type' will be used.
------------	--

If multiple HART transmitters are installed within a loop, then the HART to analog fallback option can't be used.

Fail fallback

Fallback type	1000	Determines what to do in case the input fails.
1: Last good value	Keep on using the last value that was obtained when the input was still healthy.	
2: Fallback value	Use the value as specified by parameter 'Fallback value' The fallback value is usually a fixed value and will generally never be changed during the lifetime of the flow computer.	
3: Override value	Use the value as specified by parameter 'Override value'	
Fallback value	1000	Only used when Fallback type is 'Fallback value'. Represents the value [cSt] to be used when the input fails.

Input frozen alarm

Input frozen time	1000	Maximum time [s] which the input value is allowed to remain unchanged. If the input value hasn't changed during this time, an 'input frozen' alarm is given. Enter 0 to disable this functionality.
-------------------	------	---

Viscosity calculation

Temperature input for viscosity calculation	100 0	Temperature input for viscosity calculation according to ASTM-D341-09. 1: Auxiliary temperature 1 2: Auxiliary temperature 2 Only applicable for station viscosity. For calculation of the run viscosity the meter temperature is used.
Viscosity constant A/B/C	100 0	In-use product viscosity constants A, B and C. To be used in the formula: $\log(\log(\nu + C)) = A - B * \log(T + 273.15)$ with ν = Viscosity and T = Temperature The constants for the individual products can be entered on the product definition display pages.

Viscosity referral

Station to run viscosity referral	1000	Only applicable in case of a (local or remote) station viscosity. This setting defines whether or not the run viscosity is corrected for the difference between station temperature and meter temperature. The correction is done using the ASTM D341-09 formula. 0: Disabled The run viscosity equals the station viscosity 1: Enabled An offset is calculated between the measured station viscosity and the station viscosity as calculated from the ASTM D341-09 formula (using the station temperature). Then the run viscosity is calculated using the ASTM D341-09 formula (using the run temperature) plus the offset.
-----------------------------------	------	--

Batching

By default batches are ended manually by giving a batch end command from the Batch control display. Additionally, automatic batch end commands can be configured based on time (on a daily basis or based on a schedule) or on required batch size.



Display → Configuration, Run <x>, Batching

Display → Configuration, Station, Batching

with <x> the number of the meter run

Whether batching is done on each run separately, or on the whole station at once, depends on the settings **Flow computer type** and **Common product and batching**, which are accessible through display Configuration, Overall setup, Common settings.

See paragraph 'common settings' for more details.

Batch size reached alarm

Generate alarm if batch size reached	500	Determines if a batch end alarm is given when the batch total reaches the preset batch size. 0: No 1: Yes
Batch preset warning amount	500	Volume [m3] or mass [tonne], depending on the selected batch quantity type . When the batch amount reaches the batch size minus this amount [m3], then a 'batch preset warning volume reached' alarm is given. A value of 0 disables this function.

Batch end on time

Automatic batch end mode	500	Determines if and how batches are ended automatically 0: Disabled Batches are not ended automatically 1: Daily Automatic batch end every day at the Hour of day for automatic batch end . 2: Scheduled Automatic batch ends at the scheduled batch end dates , which can be set from the operator display Batch, Scheduled batch ends, where the operator can set up to 5 scheduled batch end dates. 3: Weekly Automatic batch end every week at the Day of week for weekly batch end .
Monthly batch end	500	Enables / disables automatic monthly batch ends at the specified day(s) of month. 0: Disabled 1: Enabled
Hour of day for automatic batch end	500	Hour of the day (0-23) for automatic batch ends on time. Applicable to daily, weekly, monthly and scheduled batch ends.
Auto batch end offset minutes	500	Offset from the whole hour in number of minutes (0-59). Applicable to daily, weekly, monthly and scheduled batch ends.
Auto batch end offset seconds	500	Offset from the whole hour in number of seconds (0-59). Applicable to daily, weekly, monthly and scheduled batch ends.
Day of month for monthly	500	Specifies the day of month for automatic monthly batch ends.

batch end		
Day of month for monthly batch end 2	500	Specifies a second day of month for automatic monthly batch ends. If a second monthly batch end day is needed, enter the day of the month. If it is not needed, enter a value of 0.
Day of week for weekly batch end	500	Specifies the day of week for automatic weekly batch ends.

Batch end on batch size reached

Batch end on batch size reached	500	Automatically ends the batch when the defined batch size (from the batch stack) has been reached. 0: Disabled 1: Enabled
---------------------------------	-----	--

Batch end on no flow condition

Auto batch end at no flow	500	Automatically ends the batch when the flow stops. If enabled a batch end is given when the meter has been inactive for the delay time. 0: Disabled 1: Enabled
---------------------------	-----	---

Batch end on flow direction change

Auto batch end at no flow	500	Automatically ends the batch when the flow direction changes. If enabled a batch end is given as soon as the meter is active while the flow direction has changed 0: Disabled 1: Enabled
---------------------------	-----	--

Batch end digital input

Batch end digital input module	500	Number of the flow module to which the input signal is physically connected. -1: Local module means the module of the meter run itself
Batch end digital input channel	500	Number of the digital channel on the selected module to which the input signal is physically connected. Enter '0' to un-assign the digital input

Batch end digital output

Batch end digital output module	500	Number of the flow module to which the output signal is physically connected. -1: Local module means the module of the meter run itself
Batch end digital output channel	500	Number of the digital channel on the selected module to which the output signal is physically connected. Enter '0' to un-assign the digital output

Batch start digital input

Only applicable if the **Batch start command** is enabled (display: Configuration, Overall setup, Common settings).

Batch start digital input module	500	Number of the flow module to which the input signal is physically connected. -1: Local module means the module of the meter run itself
Batch start digital input channel	500	Number of the digital channel on the selected module to which the input signal is physically connected. Enter '0' to un-assign the digital input

Product selection

The application supports a maximum of 16 products, which can be configured from display: Configuration, Products. The product to be used for the current batch or for a scheduled batch can be set up from the batch stack display.

Alternatively the flow computer can be configured to automatically select the product based on density (density interface), a combination of 4 digital inputs, a combination of 4 bits communicated via modbus, or the position of a valve.



Display → Configuration, Run <x>, Auto product selection

Display → Configuration, Station, Auto product selection

With <x> the number of the meter run

Whether product selection is done on each run separately, or on the whole station at once, depends on the settings **Flow computer type** and **Common product and batching**, which are accessible through display Configuration, Overall setup, Common settings.

See paragraph 'common settings' for more details.

When a different product is selected, then also a batch end is given. Therefore, a batch always consists of one product only.

Product selection on density interface

Product selection on density interface	1000	Enables / disables automatic product selection based on density interface. 0: Disabled 1: Enabled For each product a product auto select density low limit and a product auto select density high limit can be configured (Display: Configuration, Products). These define the density range for each product. The selection logic looks in the product table to find out in which product's density range the actual density lies and selects the appropriate product. Be aware that the product density ranges should not overlap. If they are overlapping, the density may lie within more than one product density range. In that case the flow computer selects the product with the lowest product number.
Density interface – Density mode	1000	Product selection can be based either on observed density or on standard density. 1: Observed density 2: Standard density The first option uses the product density limits as observed density limits [kg/m ³]. The second option uses the product density limits as standard density limits [kg/sm ³].
Density interface – Delay time	1000	The density has to be within the product selection limits during the delay time [s] before the new product is selected.

Product selection on Modbus bits

Product selection on Modbus bits	1000	Enables / disables product selection through 4 bits (Product select bit 0 – 3) that are read through Modbus communication. 0: Disabled 1: Enabled The product number is calculated from the status of the 4 bits using the formula: Product number = 1 + bit3 + 2 * bit2 + 4 * bit1 + 8 * bit0 The product selection is activated with a 5 th Modbus bit: Product select bit command. Bits 0-3 are global variables, while there are separate select commands for the station and for each run.
----------------------------------	------	--

Product selection on digital inputs

Product selection on Modbus bits	1000	Enables / disables product selection through 4 digital inputs. 0: Disabled 1: Enabled The product number is calculated from the status of 4 bits that are read as digital inputs, using the formula: Product number = 1 + bit3 + 2 * bit2 + 4 * bit1 + 8 * bit0 The product selection is activated when a 5 th digital input, the product select command input is triggered. Bits 0-3 are global inputs, while there are separate inputs for the product select bit commands of the station and of each run.
Product select bit 0..3 DI module	1000	The module to which the signal is physically connected
Product select bit 0..3 DI channel	1000	The digital channel on the selected module to which the signal is physically connected (1..16)
Product select command DI module	1000	The module to which the product select command signal is physically connected -1: Local module means the module of the meter run itself
Product select command DI channel	1000	The digital channel on the selected module to which the product select command signal is physically connected (1..16)

Product selection on valve position

Product selection on valve position	1000	Enables / disables switching between product 1 and 2 based on the position of a valve. 0: Disabled 1: Enabled Two digital inputs are used to read the valve position. If the first input is activated then product 1 is selected. If the second input is activated then product 2 is selected. This option only uses products 1 and 2. The other products are not used.
Valve position – Product 1/2 DI module	1000	The module to which the valve position – product 1/2 signal is physically connected -1: Local module means the module of the meter run itself
Valve position – Product 1/2 DI channel	1000	The digital channel on the selected module to which the valve position – product 1/2 signal is physically connected (1..16)

Analog outputs

Each flow module provides 4 analog outputs, which can be set up at meter run level for **run process variables** and at station level for **station process variables**.



Display → Configuration, Run <x>, Analog outputs, Analog output <y>

Display → Configuration, Station, Analog outputs, Analog output <y>

Display → Configuration, Proving, Analog outputs, Analog output <y>

with <x> the number of the meter run

and <y> the analog output number (1-4)

Analog output <y> Variable	600	<p>The variable that is used for the analog output.</p> <p>For each run any of the following variables can be selected:</p> <ul style="list-style-type: none"> -1 : Custom 0: Not assigned 1: Indicated flow rate 2: Gross volume flow rate 3: Gross standard volume flow rate 4: Net standard volume flow rate 5: Mass flow rate 6: Standard density 7 : Meter temperature 8 : Meter pressure [bara] 9 : Meter pressure [barg] 10: Meter density 11 BS&W 12: Observed density <hr/> <p>For the station the following variables can be selected:</p> <ul style="list-style-type: none"> -1 : Custom 0: Not assigned 2: Gross volume flow rate 3: Gross standard volume flow rate 4: Net standard volume flow rate 5: Mass flow rate 6: Standard density 7: BS&W 8: Observed density <hr/> <p>For proving any of the following variables can be selected:</p> <ul style="list-style-type: none"> -1 : Custom 0: Not assigned 1: Prover A inlet temperature 2: Prover A outlet temperature 3: Prover A average temperature 4: Prover A rod temperature 5: Prover A density temperature 6: Prover A inlet pressure 7: Prover A outlet pressure 8: Prover A average pressure 9: Prover A plenum pressure 10: Prover A density pressure 11: Prover A observed density [kg/m3] 12: Prover A observed density [API] 13: Prover A observed relative density 14: Prover B inlet temperature 15: Prover B outlet temperature 16: Prover B average temperature 17: Prover B rod temperature 18: Prover B density temperature 19: Prover B inlet pressure 20: Prover B outlet pressure
----------------------------	-----	---

		<ul style="list-style-type: none"> 21: Prover B average pressure 22: Prover B plenum pressure 23: Prover B density pressure 24: Prover B observed density [kg/m3] 25: Prover B observed density [API] 26: Prover B observed relative density <p>Selection 'Not assigned' disables the output</p> <p>If 'Custom' is selected then the value that is written (by a custom calculation) to the Analog output <y> custom value will be used. This option can be used to send any other variable to an analog output.</p>
Analog output <y> module	600	<p>Number of the flow module that is used for this output.</p> <p>-1: Local module means the module of the meter run itself</p>
Analog output <y> channel	600	<p>Analog output channel on the specified module that is used for this output.</p>



The analog output scaling and dampening factors can be configured on the I/O configuration display: IO, Module <x>, Configuration, Analog outputs, Analog output <y>

Pulse outputs

tonne) have been accumulated.

Each flow module provides a maximum of 4 pulse outputs.

Pulse outputs can be set up both at meter run level for **run totals** and at station level for **station totals**.

In order to be able to use a digital channel as a pulse output, the channel must be configured as **Pulse output (1-4)** (I/O, Module <y>, Configuration, Digital IO assign).



Display → Configuration, Run <x>, Pulse outputs, Pulse output <y>

Display → Configuration, Station, Pulse outputs, Pulse output <y>

with <x> the number of the meter run

and <y> the pulse output number (1-4)

Pulse output <y> totalizer	600	<p>The totalizer that is used for the pulse output.</p> <p>--1: Custom</p> <p>0: Not assigned</p> <p>1: Indicated (forward)*</p> <p>2: Gross volume (forward)</p> <p>3: Gross standard volume (forward)</p> <p>4: Net standard volume (forward)</p> <p>5: Mass (forward)</p> <p>6: Good pulses (forward)*</p> <p>7: Error pulses (forward)*</p> <p>8: Indicated (reverse)*</p> <p>9: Gross volume (reverse)</p> <p>10: Gross standard volume (reverse)</p> <p>11: Net standard volume (reverse)</p> <p>12: Mass (reverse)</p> <p>13: Good pulses (reverse)*</p> <p>14: Error pulses (reverse)*</p> <p>15: Indicated (forward/reverse)*</p> <p>16: Gross volume (forward/reverse)</p> <p>17: Gross standard volume (forward/reverse)</p> <p>18: Net standard volume (forward/reverse)</p> <p>19: Mass (forward/reverse)</p> <p>20: Good pulses (forward/reverse)*</p> <p>21: Error pulses (forward/reverse)*</p> <p><i>*Only available on meter run level</i></p> <p>Selection 'Not assigned' disables the output.</p> <p>If 'Custom' is selected, then the value that is written to the tag Pulse output <y> custom increment will be used. Use this option if you want to apply user-defined calculations to the totalizers, f.e. converting them into different units.</p>
Pulse output <y> module	600	<p>Number of the flow module to which the signal is physically connected.</p> <p>-1: Local module means the module of the meter run itself</p>
Pulse output <y> index	600	<p>Pulse output number on the specified module that is used for the signal.</p> <p>1: Pulse output 1</p> <p>2: Pulse output 2</p> <p>3: Pulse output 3</p> <p>4: Pulse output 4</p>
Pulse output <y> Quantity per pulse	600	<p>Factor that specifies the amount that corresponds to 1 pulse. The unit depends on the totalizer that has been selected: [m3/pls], [sm3/pls] or [tonne/pls].</p> <p>E.g. a value of 100 means that 1 pulse is generated whenever 100 input units (m3, sm3 or</p>

Frequency outputs

Each flow module provides a maximum of 4 frequency outputs, each of which can be used to output a process variable (e.g. a flow rate) as a periodic signal with a frequency proportional to the process value.

Frequency outputs can be set up both at meter run level for **run process variables** and at station level for **station process variables**.

In order to be able to use a digital channel as a frequency output, the channel must be configured as **Frequency output (1-4)** (I/O, Module <y>, Configuration, Digital IO assign).



The use of frequency outputs is only supported by FPGA version 1422-21-2-2012 or later.



Display → Configuration, Run <x>, Frequency outputs, Frequency output <y>

Display → Configuration, Station, Frequency outputs, Frequency output <y>

with <x> the number of the meter run

and <y> the frequency output number (1-4)

Pulse output <y> totalizer	600	The totalizer that is used for the frequency output. --1: Custom 0: Not assigned 1: Gross volume flow rate 2: Gross standard volume flow rate 3: Net standard volume flow rate 4: Mass flow rate Selection 'Not assigned' disables the output. If 'Custom' is selected then the value that is written (by a custom calculation) to the Frequency output <y> custom value will be used. This option can be used to send any other variable to a frequency output.
Frequency output <y> module	600	Number of the flow module to which the signal is physically connected. -1: Local module means the module of the meter run itself
Frequency output <y> index	600	Frequency output number on the specified module that is used for the signal. 1: Frequency output 1 2: Frequency output 2 3: Frequency output 3 4: Frequency output 4



The frequency output scaling factors (zero and full scale values and frequencies) can be configured on the I/O configuration display: IO, Module <x>, Configuration, Frequency outputs, Frequency output <y>

Snapshot report



Display → Configuration, Run <x>, Snapshot report

Display → Configuration, Station, Snapshot report

with <x> the number of the meter run

Snapshot report	600	Defines whether or not snapshot reports can be generated. 0 : Disabled 1: Enabled Please be aware that a snapshot report has to be configured and enabled in Flow-Xpress prior to writing the application to the flow computer.
-----------------	-----	--

Snapshot digital input

Optionally a digital input can be used to issue a snapshot request command, in order to generate (and print) a snapshot report for a specific run or for the station.

Print snapshot digital input module	600	Number of the flow module to which the input signal is physically connected. -1: Local module means the module of the meter run itself
Print snapshot digital output channel	600	Number of the digital channel on the selected module to which the input signal is physically connected. Enter '0' to un-assign the snapshot request digital input.

Valve control

The Flow-X application provides control of the following valves:

For each run:

- Run inlet valve
- Run outlet valve
- Run to prover valve
- Loading divert valve (optional)

For each prover A/B:

- Prover 4-way valve (bi-directional prover only)
- Prover outlet valve

The control logic is based on 1 common or 2 separate output signals for the valve open and close commands, and 0, 1 or 2 input signals for the valve position (Open and Closed).

The valve position is determined as follows:

- If no inputs are available, then the position is determined from the latest issued valve command. No 'traveling' or 'Fault' positions can be derived.
- If one single input is available (for either the open or the closed position), then the valve is considered to be in the opposite position if the position signal is OFF. No 'traveling' or 'Fault' positions can be derived.
- If two inputs are available, then the position is derived as follows:

Closed DI	Open DI	Valve position
ON	OFF	Closed
OFF	ON	Open
OFF	OFF	Traveling or Valve fault, depending on configured 'traveling type'
ON	ON	Traveling or Valve fault, depending on configured 'traveling type'

Separate open and close commands are available for manual and auto modes of operations. Manual mode is meant for direct control by the operator, automatic mode is meant for logic, which can be programmed through 'User calculations' in Flow-Xpress.

A time-out limit is applied to the valve travel time. A 'valve travel timeout' alarm is generated when the travel timer has reached the limit before the valve has reached its destination.

The valve may be equipped with a local / remote switch, which can be read into the flow computer through a digital input. If this input is ON, then a 'valve local control' alarm is generated and any open / close commands on the flow computer are rejected.

If the valve leaves the open or closed position while no command has been given from the flow computer (apparently because the valve is controlled locally), the travel timer is started and a 'valve travel timeout' alarm is generated when the valve remains too long in the 'traveling' state.

The valve may be equipped with a 'valve fault' digital output. This signal can be read into the flow computer through a digital input. A 'valve fault' alarm is generated when this input is ON.

Permissive flags are available to interlock the opening or closing of valves. The permissive flags are ON by default and can be set / reset through 'User calculations' in Flow-Xpress.

The 'run to prover' valve can also be used as 'crossover' valve in case of master meter proving with a so-called 'z-configuration', through which the two valves can alternatively be set in parallel or serial line-up. One of the valve position inputs can then be used to indicate to the flow computer that the valves are in serial configuration, so only one of the totals must be taken into account in the station total. See paragraph 'Serial mode' for more information.

For **prover 4-way valves** the same functionality is available as for block valves. Only the Open / Close status is replaced by Forward / Reverse. Additionally, prover 4-way valves can be equipped with leak detection, either as a digital contact, or as an analog differential pressure value. Both types are supported by the flow computer. If a leak is detected during a prove, either because the digital input is ON, or because the differential pressure is higher than a definable limit value, then the prove will be aborted.



Display → Configuration, Run <x>, Valve control

Display → Configuration, Prover A/B, Valve control

With <x> the number of the meter run

The valve control configuration displays are only visible if valve control has been enabled on the Configuration, Run <x>, Run control and / or Proving, Prover A/B, prover setup displays.

The following settings are available for each individual valve:

Valve control signals	600	0: None Valve control is disabled
		1: Two pulsed outputs Two separate outputs for open and close commands. The outputs remain ON until the valve control pulse duration time has passed.
		2: Two maintained outputs Two separate outputs for open and close commands. The outputs remain ON until the valve has reached its target position, or until the travel timeout time has passed.
		3: Single output (open) 1 output to open the valve (ON = open). After a valve open command the output stays ON until a close command is given.
		4: Single output (close) 1 output to close the valve (ON = close). After a valve close command the output stays ON until an open command is given
Valve control pulse duration	600	Only applicable if Valve control signals is set to 'Two pulsed outputs'. Defines the pulse duration [s] of the valve control output

		signals.
Valve position signals	600	0: No inputs No inputs for open and close positions. The valve position is solely derived from the latest valve command. 1: Two inputs Two separate inputs for open and close positions. 2: Single input (open) Single input that is ON when the valve is in the open position, else OFF. 3: Single input (closed) One input that is ON when the valve is in the closed position, else OFF.
Valve traveling type	600	Only applicable in case of 2 position signals. Determines how the 'traveling' and 'fault' statuses are derived: 1: Both inputs inactive The valve is in the 'traveling' state if both the open and close position inputs are OFF. The valve is in the 'fault' state if both the open and close position inputs are ON. 2: Both inputs active The valve is in the 'traveling' state if both the open and close position inputs are ON. The valve is in the 'fault' state if both the open and close position inputs are OFF.
Valve travel timeout period	600	Maximum allowed time [s] for the valve to be traveling to the required position. The valve timeout alarm is raised when the valve does not reach the required position within this time.

Position inputs

Open position DI module	600	Module to which the open position signal is physically connected. -1: Local module means the module of the meter run itself
Open position DI channel	600	Digital channel on the selected module to which the open position signal is physically connected
Closed position DI module	600	Module to which the closed position signal is physically connected. -1: Local module means the module of the meter run itself
Closed position DI channel	600	Digital channel on the selected module to which the closed position signal is physically connected

Control outputs

Open control DO module	600	Module to which the open control output signal is physically connected -1: Local module means the module of the meter run itself
Open control DO channel	600	Digital channel on the selected module to which the open control output signal is physically connected
Close control DO module	600	Module to which the close control output signal is physically connected -1: Local module means the module of the meter run itself
Close control DO channel	600	Digital channel on the selected module to which the close control output signal is physically connected

Local / remote input

Local / remote DI module	600	Module to which the local / remote signal is physically connected. -1: Local module means the module of the meter run itself
Local / remote DI channel	600	Digital channel on the selected module to which the local / remote signal is physically connected Enter 0 to disable the local / remote digital input.

Valve fault input

Valve fault DI module	600	Module to which the valve fault signal is physically connected. -1: Local module means the module of the meter run itself
Valve fault DI channel	600	Digital channel on the selected module to which the valve

channel		fault signal is physically connected. Enter 0 to disable the valve fault digital input.
---------	--	--

Open / close permissives

Valve open permissive	600	Determines whether or not a valve open permissive is taken into account. If enabled the valve can only be opened if the valve open permissive (to be written through Modbus or using a 'custom calculation') is ON. 0: Disabled 1: Enabled
Valve close permissive	600	Determines whether or not a valve close permissive is taken into account. If enabled the valve can only be closed if the valve close permissive (to be written through Modbus or using a 'custom calculation') is ON. 0: Disabled 1: Enabled

Leak detection

Leak detection type	600	0: None No leak detection available 1: Digital input Leak detection by means of a digital signal 2: dP input Leak detection through an analog differential pressure signal
Leak detection timeout	600	Only applicable to block valves. Not applicable to 4-way valves. Leak detection becomes active when the valve is closed and then remains active during this period.
Leak detection DI module	600	Only applicable if leak detection type is 'Digital input' Module to which the leak detection signal is physically connected. -1: Local module means the module of the meter run itself
Leak detection DI channel	600	Only applicable if leak detection type is 'Digital input' Digital channel on the selected module to which the leak detection signal is physically connected
Leak detection dP input	600	Only applicable if leak detection type is 'dP input' Determines which generic auxiliary input is used for the leak detection dP input. 1: Auxiliary input 1 2: Auxiliary input 2 The auxiliary inputs can be configured on display Configuration, Auxiliary inputs. They allow for reading the dP value as analog (4-20mA) or HART input, or as 'Custom value'.
Leak detection dP high limit	600	Only applicable if leak detection type is 'dP input' If during a prove the actual leak detection differential pressure gets higher than this limit value, the prove will be aborted. The unit is the same as the leak detection dP input value.

Flow / pressure control

The application supports PID control for Flow / Pressure Control Valves. PID control can be configured either on run level (separate control valves for individual meter runs) or at station level (one control valve for the whole station consisting of multiple runs). Furthermore a separate prover control valve can be controlled.

Three types of control are supported:

1. Flow control

The flow computer controls a flow control valve (FCV) to maintain a flow rate that is defined by the flow rate setpoint.

2. Pressure control

The flow computer controls a pressure control valve (PCV) to maintain a pressure that is defined by the pressure setpoint.

3. Flow /pressure control

Primary control is on flow. The flow computer tries to maintain or reach the flow rate that is defined by the flow control setpoint. In the meantime it checks that the pressure doesn't pass a pressure limit, which is defined by the pressure setpoint / limit value. The limit may be a minimum value (to ensure a minimum delivery pressure) or a maximum value (to ensure a maximum back pressure).

If the process pressure passes the limit, then the flow computer switches over to pressure control, such that the pressure is maintained at the pressure setpoint / limit value. This means that the flow will stabilize on a flow rate that differs from the original flow rate setpoint. Apparently the flow rate setpoint can't be reached without passing the pressure limit. Depending on the process properties (pressure rises or drops with increasing flow rate) and the type of pressure limit (minimum or maximum) the actual flow rate will be lower or higher than the flow rate setpoint.

The flow computer remains in pressure control mode as long as the flow rate setpoint can't be reached without passing the pressure limit. As soon as the flow rate set point can be reached without passing the pressure limit (f.e. because a different flow rate setpoint is entered), then the flow computer switches back to flow control, controls the flow rate to the flow rate setpoint and maintains it at the flow rate setpoint value.

An example. Let's consider a process for which the pressure drops with increasing flowrate and for which a minimum pressure limit is configured at 3 bar. A flow rate setpoint of 1000 m3/h is entered and the flow computer opens the FCV and the flow rate increases. At the same time the pressure drops and at a flow rate of 800 m3/h the pressure reaches the limit of 3 bar. Apparently the flow rate setpoint can't be reached without the pressure dropping below the limit. The flow computer switches over to pressure control and maintains the pressure at 3 bar. The flow rate stabilizes around 800 m3/h. Now the operator sets the flow rate setpoint at 700 m3/h. Because this is lower than the actual flow rate, it is a flow rate that is reachable without

passing the pressure limit, so the flow computer switches back to flow control and directs the flow rate to 700 m3/h. (If the operator would have chosen a setpoint above the actual flow rate, f.e. 900 m3/h, then the flow computer would have remained in pressure control mode and nothing would have happened).



Display → Configuration, Run <x>, Flow control

Display → Configuration, Station, Flow control

Display → Configuration, Proving, Flow control

With <x> the number of the meter run

The flow control configuration displays are only visible if flow control has been enabled on any of the following displays:

Configuration, Run <x>, Run control

Configuration, Station, Station control

Proving, Proving setup.

The following configuration settings are available:

Flow / pressure control mode	600	Process value that is used for PID Control. 0: None Flow / pressure control is disabled
		1: Flow control Controls the flow rate.
		2: Pressure control Controls the pressure
		3: Flow / pressure control Primarily controls the flow rate; switches over to pressure control if a configurable pressure limit is passed.

Flow control

These settings are applicable if the **Flow / pressure control mode** is set to 'Flow control' or 'Flow / pressure control'.

Flow control - Input	600	Process value that is used for flow control. 1: Gross volume Controls the gross volume flow rate [m3/hr] 2: Gross standard volume Controls the gross standard volume flow rate [sm3/hr] 3: Mass Controls the mass flow rate [tonne/hr] 4: Custom The value that is written to the tag Flow control - Custom process value will be used. Use this option if the flow rate value is sent to the flow computer over a Modbus communications link or if you want to apply user-defined calculations to the flow rate to be used for flow control.
Flow control - Proportional Gain (P)	600	Proportional gain (P) factor for flow control Controller output = Proportional gain * Actual error. Proportional Gain = 100 / Proportional Band
Flow control - Integral gain (I)	600	Integral gain (I) factor for flow control Integral gain = 1 / [Seconds per repeat], e.g. an integral gain of 0.02 means 1 repeat per 50 seconds. As a rule of thumb set this to the time [sec] it takes for the variable to react to the output.
Flow control - Full scale value	600	Highest flow rate that can be achieved by controlling the valve. Units are the same as flow rate process value. Equals the flow rate process value that corresponds to 100% control output (20 mA) if Flow Control - Reverse mode is disabled, or 0% control output (4

		mA) if Flow Control - Reverse mode is enabled. The unit is the same as the process value.
Flow control – Zero scale value	600	Lowest flow rate that can be achieved by controlling the valve. Units are the same as flow rate process value. Equals the flow rate process value that corresponds to 0% control output (4 mA) if Flow Control - Reverse mode is disabled, or 100% control output (20 mA) if Flow Control - Reverse mode is enabled. The unit is the same as the process value.
Flow control - Reverse mode	600	Enables or disables reverse control mode for flow control. 0: Disabled Select 'Disabled' if the flow rate drops when the valve closes. 1: Enabled Select 'Enabled' if the flow rate drops when the valve opens.
Flow control - Deadband	600	Deadband on flow control. Avoids that the control valve is constantly moving, even though the actual flow rate is very close to the setpoint. Flow control will be suspended if the flow rate is higher than the setpoint minus the deadband and lower than the setpoint plus the deadband. Same units as in-use process value.
Flow control – Use setpoint from run FCV	600	Only applicable for prover flow control. If enabled If disabled, 0: Disabled Prover flow control uses the flow rate setpoint of the meter run on prove. 1: Enabled Prover flow control uses a separate flow rate setpoint independent of the setpoint used for the meter run on prove.

Pressure control

These settings are applicable if the **Flow / pressure control mode** is set to 'Pressure control' or 'Flow / pressure control'.

Pressure Control – Input	600	Pressure process value used for pressure control. 1: Meter pressure Pressure control based on meter pressure (only applicable to run and prover flow control) 2: Prover pressure Pressure control based on prover pressure (only applicable to prover flow control) 3: Auxiliary pressure 1 Pressure control based on auxiliary pressure 1 4: Auxiliary pressure 2 Pressure control based on auxiliary pressure 2 5: Custom The value that is written to the tag Pressure control - Custom process value [bar] will be used. Use this option if the pressure value is sent to the flow computer over a Modbus communications link or if you want to apply user-defined calculations to the pressure to be controlled.
Pressure Control - Units	600	Defines whether the pressure setpoint is absolute pressure [bar(a)] or gauge pressure [bar(g)] (i.e. relative to the atmospheric pressure). 1: Absolute 2: Gauge
Pressure Control Proportional Gain (P)	600	Proportional gain for pressure control Controller output = Proportional gain * Actual error. Proportional Gain a = 100 / Proportional Band
Pressure Control Integral gain (I)	600	Integral gain for pressure control Integral gain = 1 / [Seconds per repeat], e.g. value of 0.02 means 1 repeat per 50 seconds.
Pressure Control Full scale value	600	Highest pressure that can be achieved by controlling the valve. Equals the pressure process value that corresponds to 100% control output (20 mA) if Pressure Control - Reverse mode is disabled, or 0% control output (4 mA)

		if Pressure Control - Reverse mode is enabled. Units are [bar(a)] or [bar(g)] depending on the Pressure Control - Units .
Pressure Control Zero scale value	600	Lowest pressure that can be achieved by controlling the valve. Equals the pressure process value that corresponds to 0% control output (4 mA) if Pressure Control - Reverse mode is disabled, or 100% control output (20 mA) if Pressure Control - Reverse mode is enabled. Units are [bar(a)] or [bar(g)] depending on the Pressure Control - Units .
Pressure Control Reverse mode	600	Enables or disables reverse control mode for pressure control. 0: Disabled Select 'Disabled' if the pressure drops when the valve closes. 1: Enabled Select 'Enabled' if the pressure drops when the valve opens.
Pressure control Deadband	600	Deadband on pressure control. Avoids that the control valve is constantly moving, even though the actual pressure is very close to the setpoint. Pressure control will be suspended if the pressure is higher than the setpoint minus the deadband and lower than the setpoint plus the deadband. Units are [bar(a)] or [bar(g)] depending on the Pressure Control - Units .
Pressure Control Setpoint type	600	1: User setpoint Uses the user pressure setpoint / limit value. 2: Offset from Pe Calculates the pressure setpoint / limit value as Equilibrium pressure (vapor pressure) + offset.
Pressure Control Setpoint	600	Only applicable if Pressure Control Setpoint type = 'User setpoint'. If Flow / pressure control mode is 'Pressure control' this is the setpoint which the control loop will try to achieve, provided that Manual control is disabled. If Flow / pressure control mode is 'Flow / Pressure control' this is the pressure limit value that is used to switch from flow control to pressure control. Units are [bar(a)] or [bar(g)] depending on the Pressure Control - Units .
Pressure limit offset from Pe	600	Only applicable if Pressure Control Setpoint type = 'Offset from Pe'. Pressure setpoint / limit offset [bar] from equilibrium pressure. Used to calculate the pressure setpoint / limit value.
Pressure Limit Mode	600	Only applicable if Flow / pressure control mode = 'Flow / pressure control'. 1: Maximum The pressure control setpoint is regarded as maximum pressure: The flow computer switches from flow control to pressure control if the pressure rises above the setpoint / limit value. 2: Minimum The pressure control setpoint is regarded as minimum pressure: The flow computer switches from flow control to pressure control if the pressure drops below the setpoint / limit value.

Setpoint clamping

Flow control - Upward setpoint clamp rate (/s)	600	The in-use flow setpoint will not be allowed to increase faster than this limit per second. If a higher setpoint is entered, the actual setpoint for the PID controller will ramp up with the specified clamp rate until the setpoint value is reached. A value of 0 disables this function
Flow control - Downward setpoint clamp rate (/s)	600	The in-use flow setpoint will not be allowed to decrease faster than this limit per second. If a lower setpoint is entered, the actual setpoint for the PID controller will ramp down with the specified clamp rate until the setpoint value is reached. A value of 0 disables this function
Pressure control -	600	The in-use pressure setpoint will not be allowed to increase faster than this limit per second.

Upward setpoint clamp rate (/s)		If a higher setpoint is entered, the actual setpoint for the PID controller will ramp up with the specified clamp rate until the setpoint value is reached. A value of 0 disables this function			control valve while there's no flow because the outlet valve is not open. 0: No 1: Yes
Pressure control - Downward setpoint clamp rate (/s)	600	The in-use pressure setpoint will not be allowed to decrease faster than this limit per second. If a lower setpoint is entered, the actual setpoint for the PID controller will ramp down with the specified clamp rate until the setpoint value is reached. A value of 0 disables this function	Use custom PID permissive	600	Allows for creating custom PID permissive logic. If enabled the PID permissive will be withdrawn (and the output will be forced to the 'Idle output %') when a 0 is written to the 'Custom PID permissive'. 0: No 1: Yes
			Custom PID permissive message	600	Message shown if custom permissive is Off.

Control output settings

Bumpless transfer	600	Controls bumpless transfer from auto to manual mode by setting the initial manual output % equal to the current valve open %. When switching from auto to manual mode while bumpless transfer is enabled, the valve effectively freezes at its position at the moment of switching. This avoids unexpected valve movements when switching from auto to manual mode. 0: Disabled 1: Enabled	Use PID active flag	600	Allows for creating custom logic to switch off PID control. If enabled the PID permissive will be withdrawn (and the output will be forced to the 'Idle output %') when a 0 is written to the 'PID active flag'. 0: No 1: Yes
Control output maximum limit	600	The control output % will not be allowed to go above this limit [%]			
Control output minimum limit	600	The control output % will not be allowed to go below this limit [%]			
Control output upward slew rate	600	The control output will not be allowed to increase faster than this limit [%/sec]. A value of 0 disables this function			
Control output downward slew rate	600	The control output will not be allowed to decrease faster than this limit [%/sec]. A value of 0 disables this function			
Idle output %		Value used for control output when the PID permissive flag is not set. This can f.e. be used to shut down the control valve if the permissive is withdrawn.			

Analog output settings

Analog output module	600	Module to which the analog control output signal is connected. -1: Local module means the module of the meter run itself
Analog output channel	600	Channel number for the analog control output signal.

Permissive settings

Withdraw permissive on flow meter error	600	Only applicable if control mode is 'Flow control' or 'Flow / pressure control'. Withdraw PID permissive in case of a meter failure (comms fail, measurement fail, etc.) or data invalid status. The output is forced to the 'Idle output %'. 0: No 1: Yes
Withdraw permissive on pressure transmitter fail	600	Only applicable if control mode is 'Pressure control' or 'Flow / pressure control'. Withdraw PID permissive in case of a pressure transmitter failure. The output is forced to the 'Idle output %'. 0: No 1: Yes
Withdraw permissive if inlet valve not open	600	Withdraw PID permissive if the 'valve open' status from the inlet valve is not received. The output is forced to the 'Idle output %'. This avoids that flow control is fully opening the control valve while there's no flow because the inlet valve is not open. 0: No 1: Yes
Withdraw permissive if outlet valve not open	600	Withdraw PID permissive if the 'valve open' status from the outlet valve is not received. The output is forced to the 'Idle output %'. This avoids that flow control is fully opening the

Sampler control

The application supports control of samplers. Sampler control can be configured either on run level (separate samplers for individual meter runs) or at station level (one sampler for the whole station consisting of multiple runs).

Single can samplers are supported, as well as twin and multiple can samplers (up to 16 cans). Several algorithms can be used for determining the time or metered volume between grabs. Also several mechanisms are available for can selection (f.e. based on product or based on customer) and can switching (f.e. at can full status or at batch end).

Sampler cleaning

Optionally logic for sampler cleaning can be enabled in order to flush the sampler when switching to a different sample can. When a different sample can is selected (either manually or automatically) the flow computer issues a predefined number of sample pulses at the highest possible frequency (defined by the sample pulse output duration). Additionally a digital output can be used to temporarily open a valve to divert the sample liquid to a trash can. (If no divert valve is available the flushing liquid ends up in the previous sample can.)



Display → Configuration, Run <x>, Sampler control

Display → Configuration, Station, Sampler control

With <x> the number of the meter run

The sampler control configuration displays are only visible if sampler control has been enabled on any of the following displays:

Configuration, Run <x>, Run control

Configuration, Station, Station control

Sampler settings

The following configuration settings are available for each sampler:

Sampler control	600	Determines whether the control of the sampler is enabled or not. Disabling control inhibits the output of grab commands (pulses) and hides the operator sampling displays. 0: Disabled 1: Enabled
Sampled flow direction	600	Only applicable to two-directional applications (Reverse totals enabled on display Configuration, Overall setup, Common settings). Determines whether the sampler will be active for both flow directions, or only for one specific flow direction. 1: Both directions 2: Forward only 3: Reverse only
Sampling method	600	The method to control the sample pulses, either flow- or time-proportional. 1: Flow (fixed value) Flow proportional method based on setting Volume between grabs fixed value . Gives a sample pulse each time this volume has been metered.

- 2: Flow (estimated volume)
Flow proportional method where the required volume between grabs is calculated from the setting **Expected total volume**, the **can volume** and the **Grab size**. The can will be full to the target level when the estimated volume has been metered.
- 3: Flow (batch volume)
Flow proportional method where the required volume between grabs is calculated from the required **Batch size** of the current batch, the **can volume** and the **Grab size**. The can will be full to the target level when the batch size is reached.
- 4: Time (fixed value)
Time proportional method based on setting **Time between grabs fixed value**. Gives a sample pulse each time this time has passed.
- 5: Time (estimated end time)
Time proportional method with the time between grabs calculated from setting **Expected end time for sampling**, the **can volume** and the **Grab size**. The can will be full to the target level at the expected end time.
- 6: Time (period)
Time proportional method with the time between grabs calculated from setting **Can fill period [hours]**, the **can volume** and the **Grab size**. The can will be full to the target level when the can fill period has passed.
- 7: Flow (auto batch end)
Only applicable if **Auto batch end on time mode** is set to 'Scheduled'. This allows for scheduling up to 5 future automatic batch ends, each of which with a scheduled **Batch end sampling volume**. The required volume between grabs is calculated from this **Batch end sampling volume**, the **can volume** and the **Grab size**. The can will be full to the target level when the batch end sampling volume is reached.
- 8: Flow (Can nomination)
For this flow proportional method to each sample can a **Can nomination** (=Expected total meter volume) can be assigned. The required volume between grabs is calculated from the **can nomination** of the selected can, the **can volume** and the **Grab size**. The can will be full to the target level when the can nomination amount is reached.

Volume between grabs value type	600	Only applicable for sampling method 'Flow (fixed value)'. Defines whether one generic 'volume between grabs' setting is used for all cans, or separate 'volume between grabs' settings for individual cans. 1: Generic value 2: Per can values For the station sampler only one generic value is available.
---------------------------------	-----	--

Grab size

Grab size value type	600	Defines whether one generic grab size value is used for all cans, or separate values for individual cans. 1: Generic value 2: Per can values For the station sampler only one generic value is available.
Grab size	600	Only applicable if the grab size value type is set to 'Generic value'. Volume of a sampler grab [cc]. Generic value for all cans.

Can size

Can volume	600	Can storage capacity [cc]. This is the volume which corresponds to '100% full'.
Can target fill percentage	600	The target level [%] to fill the can. Used to switch over to the other / next can if Auto-switch on can full is enabled and an empty can is available. In all other cases a 'Sampler can <x> at target level' alarm is raised, but sampling remains active until the can maximum fill percentage is reached.
Can maximum fill	600	The maximum fill level [%] of the can. If this level is reached, a 'Sampler can <x> at maximum level' alarm is raised and sampling is stopped.

percentage		
Can fill level indication method	600	<p>The method to read or estimate the can fill level.</p> <p>1: Number of grabs The sampler provides no fill level indication. The flow computer accumulates the number of grabs and uses this to estimate the can fill level.</p> <p>3: Analog input The sampler provides an analog input that indicates the can fill level (0-100%). This fill level is also used to derive the 'can at target level' alarm.</p>
Can full indication method	600	<p>The method used to derive the can full status / 'can at maximum fill level' alarm.</p> <p>1: Number of grabs The flow computer only uses the accumulated number of grabs to derive the can full status.</p> <p>2: Digital input The sampler provides a 'can full' digital signal. The can is considered to be full and a 'can at maximum level' alarm is generated if the digital input is high or if the accumulated number of grabs indicates that maximum fill level has been reached.</p> <p>3: Analog input The sampler provides an analog input that indicates the can fill level (0-100%). The can is considered to be full and a 'can at maximum level' alarm is generated if the analog input or the accumulated number of grabs indicates that the maximum fill level has been reached.</p>

Can selection

Can selection control mode	600	<p>Defines the method to select a can.</p> <p>0: Single can There's only one sample can, so can selection is not applicable.</p> <p>1: Twin can (1 selection output) There are two cans. Can selection is done manually, or the sampler switches automatically to the other can at batch end and / or can full condition. The can selection is sent to the sampler through 1 digital output: (output high=can 1, output low=can 2)</p> <p>2: Multiple cans (by product) There are two or more cans. To each can a product is assigned. Can selection is done based on the selected product.</p> <p>3: Multiple cans (by customer) There are two or more cans. To each customer a sample can is assigned. Can selection is done based on the selected customer.</p> <p>4: Twin can (2 selection outputs) There are two cans. Can selection is done manually, or the sampler switches automatically to the other can at batch end and / or can full condition. The can selection is sent to the sampler through 2 digital outputs: (output 1 high=can 1, output 2 high=can 2)</p> <p>5: Multiple cans (switch at batch end) There are 3 or 4 cans. Can selection is done manually, or the sampler switches automatically to the next can at batch end and / or can full condition.</p> <p>6: Multiple cans (by customer / product) There are 4, 6 or 8 cans, 2 products and maximum 4 customers. To each customer / product combination a sample can is assigned. Can selection is done based on the combination of selected customer and selected product.</p> <p>7: Multiple cans (select can) There are two or more cans. Can selection is done manually by the operator.</p>
Number of cans	600	<p>Only applicable to multiple can modes. The number of cans that are available. The maximum number of cans that can be configured is depending on the can selection control mode:</p> <p>'by product' 16 (run sampler) or 8 (station sampler) 'by customer' 16 (run sampler) or 8 (station sampler) 'switch at batch end' 4</p>

		'by customer / product' 8 'select can' 16 (run sampler) or 8 (station sampler)
Can selection digital outputs	600	<p>Only applicable to multiple can modes. Enables / disables a can selection digital output for each individual can.</p> <p>0: Disabled There are no selection valves to the separate sample cans. Can selection is done by multiple sample strobes instead (Multiple sample strobes must be enabled).</p> <p>1: Enabled For each can a separate can selection digital output is used. The digital output of the selected can is high, while all others are low. This can be used to open a valve to the selected sample can, while closing the valves to all other sample cans.</p>

Sample options

Auto-switch can on can full	600	<p>Only applicable to can selection control modes 'Twin can (1 selection output)', 'Twin can (2 selection outputs)' and 'Multiple cans (switch at batch end)'. Not available if Sampling method is 'Time (estimated end time)' or 'Flow (batch volume)'. 0: Disabled When the target fill level is reached, sampling goes on until the maximum fill level is reached and then stops. 1: Enabled When the target fill level is reached, sampling switches over to the other / next can, provided that this can is enabled and empty. If no empty can is available sampling goes on until the maximum fill level is reached and then stops.</p>
Stop sampling on batch end	600	<p>Stops the sampler if a batch end is given. 0: Disabled 1: Enabled</p>
Auto-switch can on batch end	600	<p>Selection only applicable to can selection control modes 'Twin can (1 selection output)' and 'Twin can (2 selection outputs)'. Automatically enabled for can selection control mode 'Multiple cans (switch at batch end)'. At a batch end sampling switches over to the other / next can, provided that this can is enabled and empty. If no empty can is available, sampling is stopped. 0: Disabled 1: Enabled</p>
Stop sampling on product change	600	<p>Only applicable to single and twin can modes. Stops the sampler when a different product is selected. 0: Disabled 1: Enabled</p>
Suspend sampling if batch inactive	600	<p>Determines whether or not sampling is inactive between the closing of a batch and the starting of the next batch. 0: No 1: Yes</p>

Alarm settings

Can at target level alarms	600	<p>Enables or disables the can at target level alarms. If disabled, the target level is still used in the logic to switch to another can (if applicable), but no alarm will be activated or logged. 0: Disabled 1: Enabled</p>
Can at maximum level alarms	600	<p>Enables or disables the can full alarms. If disabled, the can full status is still used in the logic to stop sampling, but no alarm will be activated or logged. 0: Disabled 1: Enabled</p>
Sample pulse alarms	600	<p>Enables or disables both the 'sampler overspeeding' alarm (indicating that more pulses are sent to the sampler than the sampler can handle) and the 'sample grabs lost' alarm (indicating that the pulse output reservoir is overflowing). 0: Disabled 1: Enabled</p>

Pulse output settings

Multiple sample strobes	600	Enables / disables a separate sample strobe (sample grabbing device) for each can. 0: Disabled The flow computer controls only one sample strobe, which is used for all cans. Only one generic pulse output has to be configured (the 'generic' pulse output; see directly below). 1: Enabled The flow computer controls a separate sample strobe for each individual can. Separate pulse outputs have to be configured for the individual cans (Display: Can settings; see the next paragraph).
Generic pulse output module	600	Only applicable if Multiple sample strobes is disabled. Module to which the generic sample strobe is physically connected. -1: Local module means the module of the meter run itself
Generic pulse output number	600	Pulse output number on the specified module that is used for the generic sample strobe. 1: Pulse output 1 2: Pulse output 2 3: Pulse output 3 4: Pulse output 4
Sample pulse output duration	600	The duration of the sample pulses [s]
Minimum time between grabs	600	Minimum time [s] between grabs. Used to determine the maximum pulse output frequency. If more pulses are requested than the maximum frequency allows for, then pulses are accumulated in the pulse reservoir.
Max. number of outstanding samples	600	The maximum number of pulses to be buffered in the pulse reservoir. Additional pulses will be lost (raises the 'Grabs lost' alarm).
Sampler overspeed alarm limit	600	If the number of pulses accumulated in the pulse reservoir reaches this limit, then the 'Sampler overspeeding' alarm is raised.

Sampler cleaning settings

These settings are only applicable for twin or multiple can samplers.

Required grab count to clean sampler	600	Number of grabs to clean the sampler when switching to a different sample can. Enter 0 to deactivate sampler cleaning.
Clean sampler digital output	600	Enables or disabled an additional digital output to control a sample liquid divert valve.
Clean sampler digital output module	600	Module to which clean sampler output signal is physically connected -1: Local module means the module of the meter run itself
Clean sampler digital output channel	600	Digital channel on the selected module to which the clean sampler output signal is physically connected

Custom flow

Use custom flow	600	Only applicable to flow based sampling. Use this option if sampling has to follow a custom calculated flow rather than the native run or station flow. 0: Disabled Sampling based on the actual station or run flow increment and flow rate. 1: Enabled Sampling based on custom calculated values that are written to the 'Sampling custom flow increment' and 'Sampling custom flow rate'.
-----------------	-----	--

Both 'Sampling custom flow increment' and 'Sampling custom flow rate' have to be written to.

'Sampling custom flow increment': flow increment (usually m3 or tonne) per flow computer cycle. This is used to calculate the number of sample pulses per cycle and actually send the pulses to the pulse output.

'Sampling custom flow rate': flow rate (unit/hr, usually m3/hr or tonne/hr). This is used to calculate the pulse frequency (only for indication on the sampler control display).

Can settings

For each available sample can the following configuration settings are available.

Can ID	600	Alphanumeric ID by which the sample can is identified, for example a tag name, product name (if the can is used for a specific product), or customer name (if the can is used for a specific customer).
--------	-----	---

Sample settings

This section contains the can specific sample settings.

Product number	600	Only applicable for can selection control mode 'Multiple cans (output per product)'. Number of the product for which the can is used. The product number is used to select the right sample can.
Nomination	600	Only applicable for can selection control mode 'Flow (can nomination)'. Expected total meter volume for this can (= can nomination). This volume is used to calculate the volume between grabs, in order to ensure that the sample can is full when the volume has been metered.
Volume between grabs	600	Only applicable for sampling method 'Flow (fixed value)' with Volume between grabs value type set to 'Per can values'. Not available for station sampler. Can specific volume between grabs value [cc].
Grab size	600	Only applicable if the Grab size value type is set to 'Per can values'. Not available for station sampler. Can specific grab size [cc].

Sample pulse output

These settings are applicable if **Multiple sample strobes** is enabled.

Pulse output module	600	Module to which the can specific sample strobe is physically connected. -1: Local module means the module of the meter run itself
Pulse output number	600	Pulse output number on the specified module that is used for the can specific sample strobe. 1: Pulse output 1 2: Pulse output 2 3: Pulse output 3 4: Pulse output 4

Can selection output

These settings are applicable if **Can selection digital outputs** is enabled.

Can selection digital output module	600	The module to which the can selection output is physically connected -1: Local module means the module of the meter run itself
Can selection digital output channel	600	The channel number on the selected module to which the can selection output is physically connected (1..16)

Can fill indication input

These settings are applicable if **Can fill level indication method** is set to 'analog input' or if the **Can full indication method** is set to 'digital input' or 'analog input'.

Can fill indication module	600	The module to which the can fill level / can full indication signal is physically connected
Can fill indication channel	600	The channel number of the can fill level / can full indication signal. In case of a digital input this is the digital channel number (1-16). In case of an analog input this is the analog input channel (1-6).

Customer cans

These settings are only available if the **Can selection control mode** is set to 'Multiple cans (by customer)' or 'Multiple cans (by cust/prd)'.

For each customer the following settings are available

Customer can number	600	The can number that is assigned to the customer (max. 16 customers).
Customer product 1/2 can number	600	The can numbers that are assigned to the customer for products 1 and 2 respectively (max. 4 customers).

Proving

The Flow-X supports sphere (ball/pipe), compact and small volume provers, as well as master meter proving.

Two provers (A and B) can be configured. The operator has the possibility to choose the prover to be used.

The proving configuration displays are only available for the following FC types:

- Proving / run
- Station / proving / run
- Station / proving
- Proving only
- Prover IO server only

Proving setup

To enable proving on the flow computer, first the settings on the proving setup configuration display have to be set. Based on these settings the appropriate configuration displays will be available.

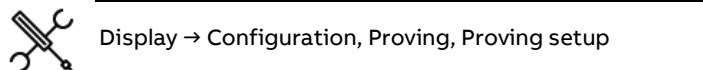

For both provers (A/B) the following setting is available:

Prover type	1000	The type of prover connected to the flow computer
		0: None
		1: Bi-directional ball
		2: Uni-directional ball
		3: Calibron / Flow MD
		4: Brooks compact
		5: Master meter

Furthermore, from this display control of the prover flow control valve / pressure control valve can be enabled or disabled.

Flow / pressure control mode	600	Process value that is used for PID Control.
		0: None
		Flow / pressure control is disabled
		1: Flow control
		Controls the flow rate.
		2: Pressure control
		Controls the pressure
		3: Flow / pressure control
		Primarily controls the flow rate; switches over to pressure control if a configurable pressure limit is passed.

Proving using a ball or compact prover

The Flow-X supports 3 different setups with aspect to proving using a ball prover, Brooks compact prover or Calibron / Flow MD small volume prover:

- 1 Multi-stream flow computer (X/P)
- 2 Prover flow computer with (single stream) remote runs
- 3 Single-stream flow computer(s) with remote prover IO server

Multi-stream flow computer (Flow-X/P)

A multi-stream (X/P) flow computer consists of up to 4 modules, each controlling a separate meter run, and a panel module that runs all proving functionality (and station functionality if applicable).

During a prove the module of the meter on prove does the pulse counting, based on the received meter pulses and one to four detector signals from the prover, which tell the module when to start and stop pulse counting.

All other proving signals (pressure and temperature transmitters, densitometer, 4-way valve statuses and commands, etc.) can be connected to any of the modules.

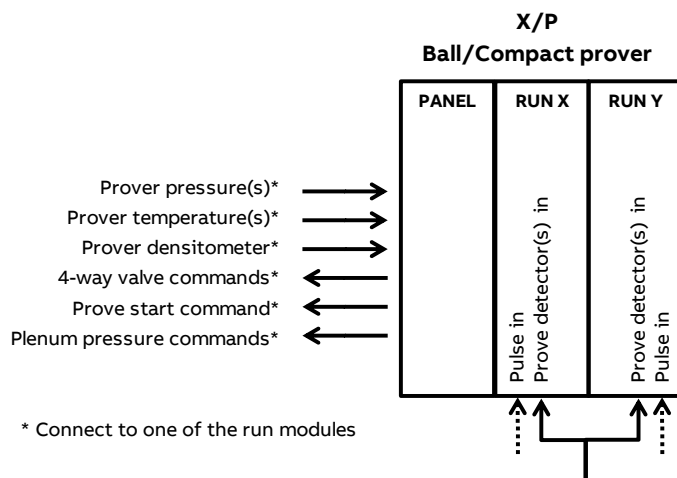

Figure 5: Proving with a ball or compact prover on an X/P flow computer.

Prover flow computer with remote runs

In this setup one flow computer is configured as 'proving only' flow computer, while there's a separate, single-stream remote run only flow computer for each individual meter run.

This way up to eight run flow computers can be connected as 'remote runs' to the prover flow computer. The prover flow computer is running the prover logic and is communicating to the remote runs through Modbus in order to gather the process data that's needed to do the proving calculations and to write the prove results to the module of the meter on prove.



In order to be able to communicate to the remote 'remote run' flow computer(s), the proving flow computer must have a 'Connect to remote run' Modbus driver configured for every individual remote run flow computer (in Flow-Xpress 'Ports and Devices').

On the remote run flow computer(s) the 'Connect to remote station' Modbus driver has to be enabled (in Flow-Xpress 'Ports and Devices').

All proving signals (pressure and temperature transmitters, densitometer, 4-way valve statuses and commands, etc.), including the detector signal(s), are connected to the prover flow computer.

The meter pulses of the meter on prove are forwarded to the prover flow computer through the prover bus. Based on the selected meter to be proved the prover flow computer decides which remote run flow computer has to forward its received meter pulses to the prover bus and enables the 'prover bus pulse output' of that flow computer accordingly.

Additional station functionality (like station totals or a station densitometer) may be enabled on the prover flow computer (FC type: 'station / proving').

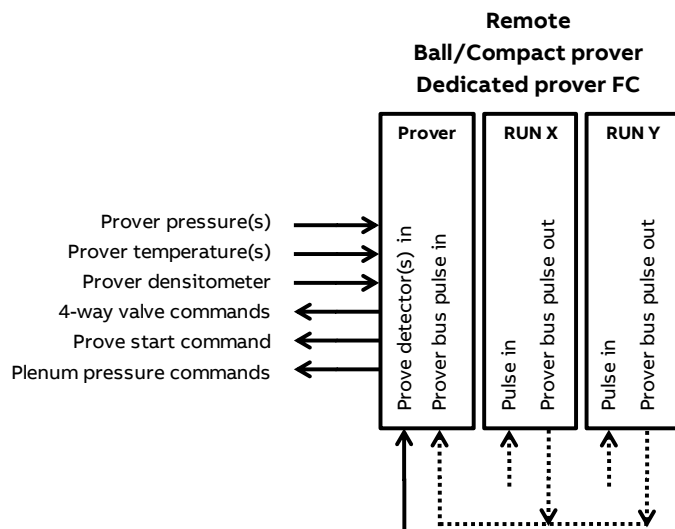

Figure 6: Dedicated prover flow computer with remote run flow computers.

It's also possible to enable proving functionality on the first run flow computer. In that case the prover flow computer has to be configured as 'proving / run' flow computer (the other flow computers have to be configured as 'run only'). This way the prover flow computer can prove one local run (run 1) and up to 7 remote runs (runs 2-8).

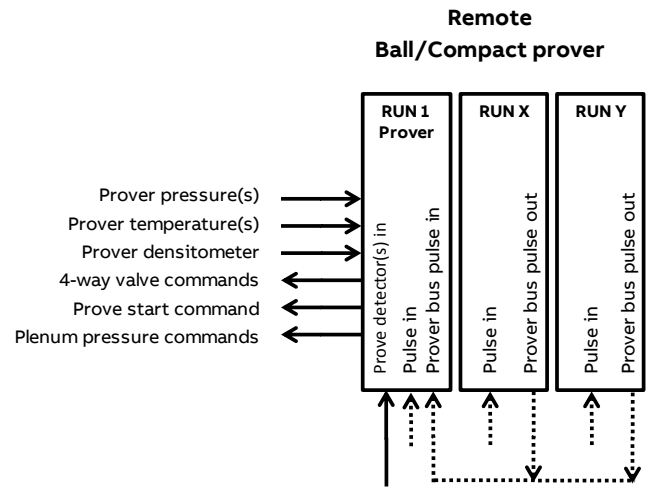

Figure 7: Prover flow computer with one local run and remote run flow computers.

Additional station functionality (like station totals or a station densitometer) may be enabled on the prover flow computer (FC type: 'station / proving / run').

Single-stream flow computers with prover IO server

In this setup a large number (up to 20 or more) of single stream flow computers are communicating through Modbus to a flow computer that has been configured as FC type 'prover IO server'. To this 'Prover IO server' all prover IO except the detector signals are connected: pressure and temperature transmitters, densitometer, 4-way valve statuses and commands, etc.

Proving is enabled on all individual run flow computers (FC type: 'proving / run'), so they each can prove their own meter. While running a prove the run flow computer reads all prove data (transmitter values, valve statuses etc.) from the 'Prover IO server' flow computer and sends any prove commands (valve commands, start command, etc.) to the 'Prover IO server' flow computer, which forwards them to the prover.

The 'Prover IO server' doesn't run any proving logic and only forwards the transmitter values / statuses / commands between the run flow computers and the prover.

As each individual run flow computer can prove its own meter, the prove detector signals are connected to all run flow computers.

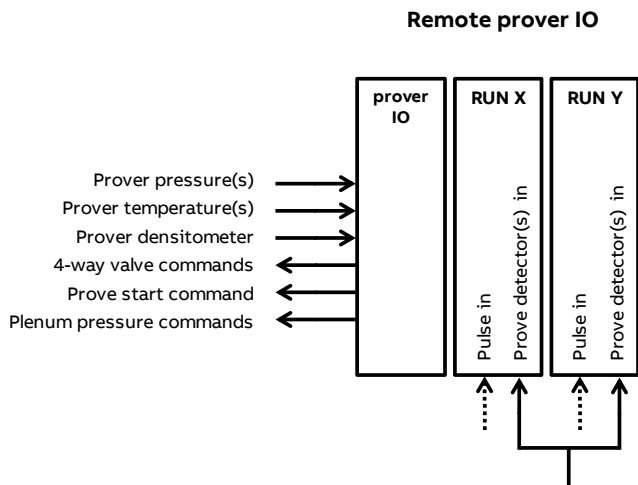

Figure 8: Single stream flow computers using a common prover IO server module.

It's also possible to enable meter run functionality on the prover IO server as well. This can be done by configuring it as **'Proving / run'**:

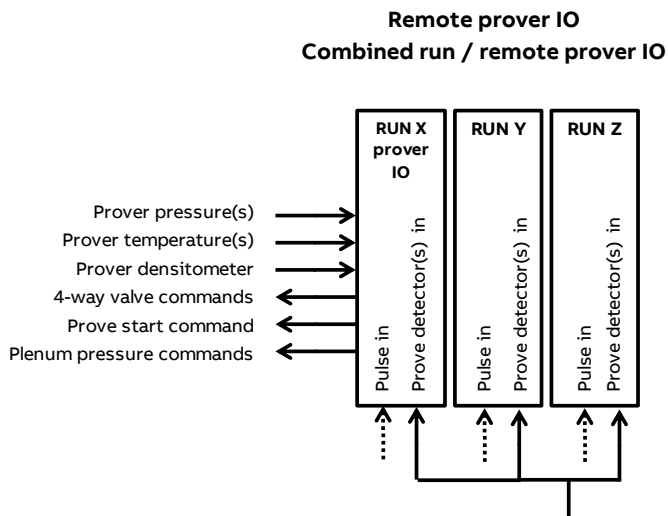

Figure 9: Single stream flow computers using a common prover IO server module. Combined run / remote prover IO module.

In this setup the 'remote prover IO' flow computer proves its own run using locally connected prover IO, while the other flow computer borrow the prover IO from the first one, as described above.

Prover setup

For each prover A/B an overall 'Prover setup' configuration display is available, on which the available devices (temperature transmitters, pressure transmitters, densitometer, valves, remote IO module) can be specified.

Based on these settings the detailed configuration displays of the selected devices are available further down the menu.

Local / remote prover IO

The following signals can either be connected **locally** to the flow computer that does the proving, or to a **remote** 'prover IO server'

module (a flow computer with **FC type** configured as 'prover IO server'), to which the flow computer communicates through Modbus.

Transmitters

- Prover inlet temperature
- Prover outlet temperature
- Prover rod temperature (Calibron / Flow MD small volume provers)
- Prover inlet pressure
- Prover outlet pressure
- Prover plenum pressure (Brooks compact prover)
- Prover density
- Prover density temperature
- Prover density pressure

Valve commands and statuses (bi-directional ball prover)

- 4-way valve FWD command
- 4-way valve REV command
- 4-way valve FWD status
- 4-way valve REV status

Prover commands and statuses

- Prove start command (uni-directional ball prover, Calibron, Flow MD and Brooks provers)
- Piston upstream status (Brooks compact prover)
- Plenum pressure charge command (Brooks compact prover)
- Plenum pressure vent command (Brooks compact prover)
- Low Nitrogen status (Brooks compact prover)

Using a remote 'prover IO server' module enables multiple flow computers to use the same prover IO.

! The **prove detector signals** have to be connected to the flow computer that does the prove, even when a remote 'prover IO server' module is used. If multiple flow computers are using one and the same prover, the prover detector signals have to be split and connected to each of the flow computers.

! In order to be able to communicate to the remote 'prover IO module' the flow computer that does the proving must have the **'Connect to remote prover IO server'** driver configured in Flow-Xpress 'Ports and Devices'.

On the remote prover IO server module the **'Act as remote prover IO server'** driver has to be enabled in Flow-Xpress 'Ports and Devices'

Local / remote prover IO	1000	1: Local The prover transmitters, commands and statuses are connected locally (i.e. directly to the flow computer itself).
		2: Remote The prover commands and statuses are connected to a remote 'prover IO server' module. The prover transmitters (temperature, pressure and density)

		may also be connected to the remote 'prover IO server' module. When configuring a prover transmitter, its input type configuration setting has an extra option 'Prover remote IO server', which can be selected to read the transmitter value from the remote 'Prover IO server' module.
Prover remote IO server device nr.	1000	Internal device nr. of the remote prover IO server as assigned in the configuration software (Flow-Xpress: 'Ports & Devices')

Prover temperature

Settings to enable and configure the prover temperature transmitters. See paragraph 'Temperature setup' for more details.

Prover pressure

Settings to enable and configure the prover pressure transmitters. See paragraph 'Pressure setup' for more details.

Prover density

Settings to enable and configure a prover densitometer and prover temperature / prover pressure transmitters. See paragraph 'Density setup' for more details.

Valve control

Settings to enable and configure control of a prover 4-way valve and prover outlet valve. See paragraph 'Valve control' for more details.

Pipe, compact and small volume prover setup

These settings are available for prover A and/or Prover B if the **Prover type** is set to 'Bi-directional ball', 'Uni-directional ball', 'Calibron / Flow MD' or 'Brooks compact'.



Display → Configuration, Proving, Prover A/B, Pipe Prover

Display → Configuration, Proving, Prover A/B, Calibron flowMD prover

Display → Configuration, Proving, Prover A/B, Brooks prover

Prover identification

Prover tag name	600	The prover tag number, e.g. "PR-003" (in accordance with the P&ID)
Prover ID	600	The prover ID, e.g. "16 inch prover".
Prover manufacturer	600	Manufacturer name
Prover material	600	Material of the prover body, e.g. 'Stainless steel'
Prover serial number	600	Serial number of the prover (as assigned by the supplier), e.g. 'PU-98756DF'

Prover properties

Prover internal diameter	1000	Prover internal diameter [mm]. Used to calculate the correction factor for the influence of pressure on the prover steel C_{psp} .
Prover wall thickness	1000	Prover wall thickness [mm]. Used to calculate the correction factor for the influence of pressure on the prover steel C_{psp} .
Prover cubic expansion coefficient	1000	Only applicable to bi-directional and unidirectional pipe provers. Prover cubic expansion coefficient [(mm ³ /mm ³)/°C]. Used to calculate the prover correction factor for the

		influence of temperature on the prover steel C_{tsp} . Typical values are: 5.18e-5 for 304 stainless steel, 4.77e-5 for 316 stainless steel, 3.13e-5 for carbon steel and 3.35e-5 for mild steel.
Prover square expansion coefficient	1000	Only applicable to Brooks compact provers and Calibron / Flow MD small volume provers. Prover square (area) expansion coefficient [(mm ² /mm ²)/°C]. Used to calculate the prover correction factor for the influence of temperature on the prover steel C_{tsp} . Typical values are 3.46e-5 for 304 stainless steel, 3.19e-5 for 316 stainless steel, 2.01e-5 for carbon steel and 2.23e-5 for mild steel.
Piston rod linear expansion coefficient	1000	Only applicable to Brooks compact provers and Calibron / Flow MD small volume provers. Piston rod linear expansion coefficient [(mm/mm)/°C]. Used to calculate the prover correction factor for the influence of temperature on the prover steel C_{tsp} . Typical values are 1.44e-7 for Invar (Brooks), 1.73e-5 for 304 stainless steel and 15.9e-5 for 316 stainless steel. A value of 0 disables the correction.
Prover modulus of elasticity	1000	Modulus of elasticity [bar*(mm/mm)]. Used to calculate the correction factor for the influence of pressure on the prover steel C_{psp} . Typical values are 2.068e6 for carbon / mild steel, 1.931e6 for 304 / 316 stainless steel and 1.9655 e6 for 17-4PH stainless steel.
Prover reference temperature	1000	Reference temperature for C_{tsp} calculation. Typically 15 °C.
Prover reference pressure	1000	Reference pressure for C_{psp} calculation. Usually 0 bar(g).

Prover position

These settings are only available for Brooks compact provers.

Prover position	1000	Defines whether the prover is installed at the inlet or outlet side of the meter. 1: At meter inlet 2: At meter outlet
Upstream prover volume multiplier	1000	Multiplier used to calculate the prover volume if the prover is at the outlet side of the meter. In this case the prover volume ('upstream volume') is smaller because the prover rod is in the prover volume.
Prover orientation	1000	The orientation of the prover. 1: Horizontal 2: Vertical The orientation is used for the calculation of the required plenum pressure.

Detector configuration

Detector configuration	1000	The application supports the following combinations of prover detector inputs signals. 1: 1 common input The start and stop detectors are combined in one <u>common</u> input signal (detector input A) 1 calibrated volume needs to be defined: AC 2: 2 inputs AC 1 start detector (detector input A) and 1 stop detector (detector input C) 1 calibrated volume needs to be defined: AC 3: 3 inputs ACD 1 start detector (input A) and 2 stop detectors (inputs C and D). 2 calibrated volumes need to be defined: AC and AD 4: 4 inputs ABCD 2 start detectors (inputs A and C) and 2 stop detectors (inputs B and D) 4 calibrated volumes need to be defined: AC, AD, BC and BD The digital input channels for the detector signals A, B, C and D are defined on display IO, Module <x>.
------------------------	------	---

Configuration, Digital IO assign.

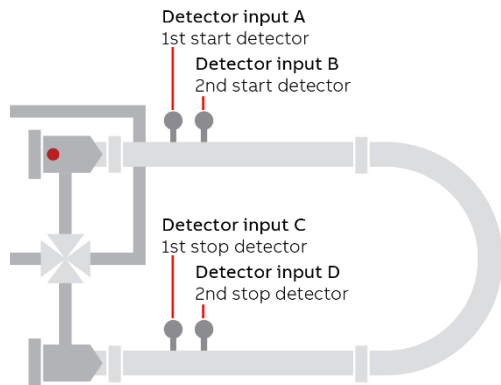

Figure 10: Prover detector switches

Single detector delay	1000	Debounce time used for detector inputs. During this time the flow computer ignores the next detector signal. Prove detectors switches are mechanical devices that may provide a bouncing signal causing the flow computer to abort the prove sequence if not debounced adequately. Therefore a proper debounce time (e.g. 0.2 seconds) has to be defined in case of a common start / stop detector input.
-----------------------	------	---

Prover volumes

Prover volume 1 (AC)	1000	Calibrated prover volume (forward plus reverse in case of bi-directional prover) between detectors A and C. This volume is used if Detector configuration is set to 1 or 2 detector inputs.
Prover volume 2 (AD)	1000	Calibrated volume (forward plus reverse in case of bi-directional prover) between detectors A and D. Only used if Detector configuration is set to 3 or 4 detector inputs.
Prover volume 3 (BC)	1000	Calibrated volume (forward plus reverse in case of bi-directional prover) between detectors B and C. Only used if Detector configuration is set to 4 detector inputs.
Prover volume 4 (BD)	1000	Calibrated volume (forward plus reverse in case of bi-directional prover) between detectors B and D. Only used if Detector configuration is set to 4 detector inputs.
Prover volume 5 (BD/CA)	1000	Calibrated volume (forward plus reverse) between detectors B and D (fwd) and C and A (rev). Only applicable to bi-directional pipe provers with Detector configuration set to 4 detectors inputs.
Selected prover volume	1000	Selects the prover base volume (i.e. the pair of detectors used for proving). Only applicable if 3 or 4 detector inputs are configured. For 1 or 2 inputs 'Volume 1 (A-C)' is used automatically. Resets to 'Volume 1 (A-C)' if the selection is invalid.

Prove timing

Pre-travel delay time	1000	Minimum pre-travel time. After the launch command the sequence waits for this time [s] before looking at the 1st detector.
Travel time-out mode	1000	The maximum pre-travel time and the over-travel time are either based on a specified time or calculated from specified volumes. 1: Time 2: Volume The latter method automatically adjusts for the actual flow rate. So at a low flow rate the allowable time-out period will be longer and at a higher flow rate it will be shorter.
Maximum pre-travel time	1000	Only used if Travel time-out mode is set to 'Time' Maximum time [s] allowed before the start detector switch is activated. If the start detector switch is not activated before this time has passed, then the prove sequence is aborted.
Pre-travel volume	1000	Only used if Travel time-out mode is set to 'Volume' Volume [m3] used to calculate the maximum time allowed for the sphere / piston to activate the start

		detector switch. $\text{Pre-travel-time [s]} = \text{Pre-travel volume [m3]} / \text{Actual flow rate [m3/hr]} * 3600 * 1.25$ (i.e. margin of 25%)
Maximum prove time	1000	Maximum time [s] allowed between activation of the start detector switch and activation of the stop detector switch. If the stop detector switch is not activated before this time has passed, then the prove sequence is aborted.
Over-travel time		Only used if Travel time-out mode is set to 'Time' Time [s] to wait after the prove run has been completed and before the next command is issued. The next command depends on the prover type : <ul style="list-style-type: none"> • Bi-directional pipe Issue the next 4-way fwd/rev command • Uni-directional Issue the next prove start command • Calibron / Flow MD small vol. Issue the next prove start command • Brooks compact Retract the prove start command so the piston travels back in upstream direction
Over-travel volume	1000	Only used if Travel time-out mode is set to 'Volume' Volume [m3] used to calculate the time to wait after the prove run has been completed and before the next command is issued. $\text{Over-travel time [s]} = \text{Over-travel volume [m3]} / \text{Actual flow rate [m3/hr]} * 3600 * 1.25$ (i.e. margin of 25%)
Piston upstr travel timeout	1000	Only applicable to Brooks compact provers. Timeout [s] for the piston traveling upstream. If the piston doesn't reach the upstream position detector before this timeout has passed, then the prove is aborted.

Meter factor calculation

Meter factor calculation method	1000	API MPMS 12.2.3 meter factor calculation method. 1: Average Data Method The final meter factor is calculated from average input data (average pulse count, average meter and prover pressure, average meter and prover temperature, average density, etc.) of the accepted prove runs. The repeatability criterion for the average data method is based on the pulse counts of the consecutive prove runs. 2: Average Meter Factor Method The final meter factor is calculated as the average of the intermediate meter factors of the accepted prove runs. The repeatability criterion for the average meter factor method is based on the calculated meter factor of the consecutive prove runs
---------------------------------	------	---

Prove start / prove run command

Defines the output to be used for the prove start or prove run command.

For uni-directional ball provers and Calibron / Flow MD small volume provers the **prove start** output is pulsed at the start of each prove pass. The pulse duration can be configured at display IO, module <x>, Configuration, Digital IO settings: Min. activation. Lowest activation time is 0.5 sec.

For Brooks compact provers the **prove run** command remains high during the entire prove pass. At the end of the pass the command is released, which causes the piston to travel back to its upstream position.

Prove start / Prove run DO module	1000	Number of the module to which the Prove start / Prove run digital output signal is physically connected.
Prove start DO channel	1000	Channel number of the Prove start / Prove run digital output signal.

Piston upstream input

These settings are only available for Brooks compact provers.

Piston upstream DI module	1000	Number of the module to which the Piston in upstream position digital input signal is physically connected.
Piston upstream DI channel	1000	Channel number of the Piston in upstream position digital input signal

Plenum pressure control

These settings are only available for Brooks compact provers.

Plenum pressure control	1000	Enables or disables the control of the pressure in the plenum chamber														
Plenum pressure check timeout	1000	Maximum allowable time [s] for the plenum pressure to get within the control limits at the start of the prove sequence. If the plenum pressure doesn't get within control limits before this timeout has passed, then the prove is aborted.														
Plenum pressure constant R	1000	The Plenum Pressure Constant R is used to calculate the plenum pressure needed to operate the Brooks compact prover. The calculation is as follows: $\text{Plenum Pressure} = (\text{Prover Pressure} / \text{Plenum Constant R}) + 60 \text{ psig}$ <p>if prover orientation is horizontal</p> <p>and</p> $\text{Plenum Pressure} = (\text{Prover Pressure} / \text{Plenum Constant R}) + 40 \text{ psig}$ <p>if prover orientation is vertical.</p> <p>Constant R depends on the size of the prover.</p> <table border="0"> <tr> <td>8 inch</td> <td>3.5</td> </tr> <tr> <td>12 inch Mini</td> <td>3.2</td> </tr> <tr> <td>12-inch</td> <td>3.2</td> </tr> <tr> <td>18 inch</td> <td>5</td> </tr> <tr> <td>24-inch</td> <td>5.88</td> </tr> <tr> <td>34-inch</td> <td>3.92</td> </tr> <tr> <td>40-inch</td> <td>4.45</td> </tr> </table>	8 inch	3.5	12 inch Mini	3.2	12-inch	3.2	18 inch	5	24-inch	5.88	34-inch	3.92	40-inch	4.45
8 inch	3.5															
12 inch Mini	3.2															
12-inch	3.2															
18 inch	5															
24-inch	5.88															
34-inch	3.92															
40-inch	4.45															
Plenum pressure control deadband	1000	Deadband [%] applied on the required plenum pressure to control the plenum pressure. A charge command is given if: $\text{Plenum pressure} < \text{Required plenum pressure} * (100 - \text{Deadband}) / 100$ <p>A vent command is given if: $\text{Plenum pressure} > \text{Required plenum pressure} * (100 + \text{Deadband}) / 100$ </p>														
Plenum pressure alarm deadband	1000	If the actual plenum pressure deviates more from the required value than this alarm deadband, then the prove sequence is aborted.														

Charge plenum command

These settings are only available for Brooks compact provers.

Charge plenum DO module	1000	Number of the module to which the Charge plenum digital output signal is physically connected.
Charge plenum DO channel	1000	Channel number of the Charge plenum digital output signal

Vent plenum command

These settings are only available for Brooks compact provers.

Vent plenum DO module	1000	Number of the module to which the Vent plenum digital output signal is physically connected.
Vent plenum DO channel	1000	Channel number of the Vent plenum digital output signal

Low nitrogen input

These settings are only available for Brooks compact provers.

Low nitrogen DI module	1000	Determines whether or not a low N2 pressure switch is available. If low N2 pressure is detected, a prove can't be started or is aborted. 0: Disabled 1: Enabled
Low nitrogen DI module	1000	Number of the module to which the Low nitrogen level digital input signal is physically connected.
Low nitrogen DI channel	1000	Channel number of the Low nitrogen level digital input signal

Master meter proving

The Flow-X supports master meter proving, in which the readings of two meters that are set in serial configuration (the meter on prove and the master meter) are compared in order to calculate a correction factor (Meter Factor) for the meter on prove.

In the Flow-X, the meter on prove and the master meter are regarded as two meters that are part of a station. Each meter is connected to its own module. The prove logic and calculations are running on the panel module (in case of a Flow-X/P), or on one of the run modules (meter on prove or master meter; FC type: '**proving / run**'), or by a third module (dedicated prove module of type '**proving only**').

The proving flow computer can contain a local run and one or more remote runs. It communicates to its remote run flow computers through Modbus to gather the process data that's needed to do the proving calculations, to give the commands to start / stop the prove and to write the prove results.



In order to be able to communicate to the remote 'remote run' flow computer(s), the proving flow computer must have a '**Connect to remote run**' Modbus driver configured for every individual remote run flow computer (in Flow-Xpress 'Ports and Devices').

On the remote run flow computer(s) the '**Connect to remote station**' Modbus driver has to be enabled (in Flow-Xpress 'Ports and Devices').

Additional station functionality (like station totals or a station densitometer) may be enabled on the prover flow computer (FC types: '**station / proving**' or '**station / proving / run**').

Master meter proving based on totalizers

Master meter proving can be based on pulses or on totalizers. In case of **master meter proving based on totalizers**, communication between the modules is entirely by Modbus and no separate connections have to be made to pass through the meter pulses or to send a prove start / stop command:

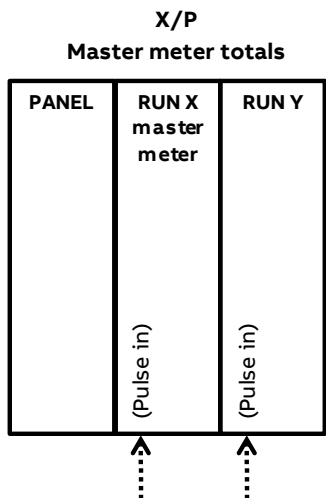

Figure 11: Master meter proving based on totalizers on an X/P flow computer.

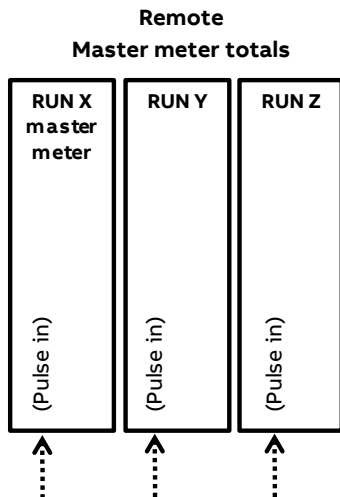

Figure 12: Master meter proving based on totalizers on a proving flow computer with remote runs.

Master meter proving based on pulses

In case of **master meter proving based on pulses**, a prove start command is used to start / stop pulse counting on the master meter module and meter module. This command ensures that the meter module and master meter module start / stop pulse counting at exactly the same time.

On an **X/P flow computer** the prove start output has to be connected to a digital input on the module of each meter that can be proved and on the master meter module. The command output digital channel has to be configured as 'Digital output',

the inputs as 'Common detector' (display: IO, module <x>, Configuration, Digital IO assignment).

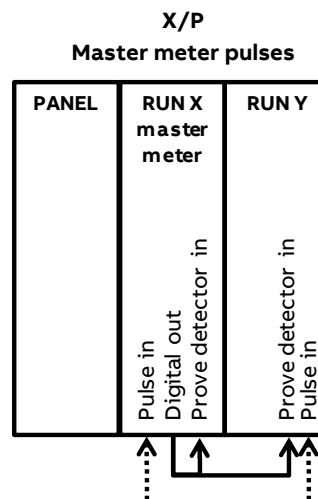

Figure 13: Master meter proving based on pulses on an X/P flow computer.

In case of **master meter proving based on pulses** with a **prover flow computer** using the 'remote run' functionality, the start / stop command output has to be connected to a digital input on the prover flow computer only. In this case the prover flow computer reads both the meter pulses and the master meter pulses. The command output digital channel has to be configured as 'Digital output', the input as 'Common detector' (display: IO, module <x>, Configuration, Digital IO assignment).

The figures below show the connections for a combined 'proving / run' flow computer that holds the master meter (the master meter is a local run and the meter on prove is a remote run) and for a dedicated 'proving only' flow computer that holds no local meter (both the master meter and the meter on prove are remote runs).

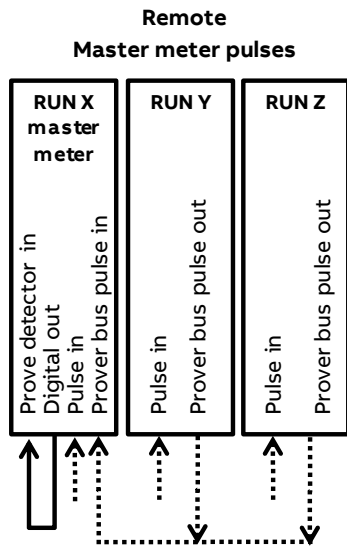

Figure 14: Master meter proving based on pulses on a prover flow computer with remote runs; master meter as local run on the prover flow computer.

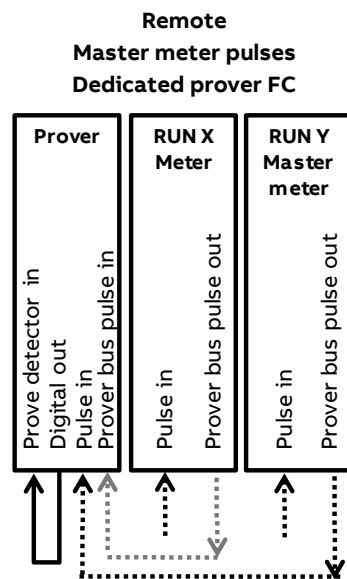



Figure 15: Master meter proving based on pulses on a prover flow computer with remote runs; master meter on separate module.

The prover flow computer decides which remote meter flow computer has to forward its input pulses to the prover bus and enables the 'prover bus pulse output' of this flow computer accordingly.

Master meter proving setup

 Display → Configuration, Proving, Prover A/B, Master meter proving

These settings are available if the **Prover type** is set to 'Master meter proving'.

Master meter number	500	Number of the meter (in the proving flow computer) that is used as master meter. In case of a Flow-X/P, the meter number corresponds to physical position of the related flow module in the proving flow computer. The selected master meter may be a local run or a remote run. Enter 0 to activate master meter proving with one module only (with limited functionality). See paragraph 'Master meter proving with one module only' for more details.
Master meter proving type	1000	Defines whether master meter proving is based pulses or on totalizers. 1: Pulses The pulses from both the meter on prove and the master meter are counted. The pulse counts are used to calculate the prove volumes, from which the meter factor is calculated. This option can only be used if both meters have a pulse output. 2: Totalizers The gross volume or mass totalizers from both the meter on prove and the master meter are simultaneously latched at the start of the prove and at end of the prove. From these totalizers prove volumes for the meter on prove and the master meter are calculated and from these the meter factor is calculated. This option is also available for meters without pulse output.

Prove size

Master meter prove size type	1000	Determines whether the prove size is specified as prove duration or as volume / mass. 1: Prove volume / mass If the meter on prove is a volumetric meter, the prove size is specified as volume [m3]. If the meter on prove is a mass meter, the prove size is specified as mass [tonne]. 2: Prove time The prove size is specified as time [min].
Volume / mass per prove run	500	Only applicable if Master meter prove size type is set to 'Prove volume / mass'. Volume or mass to be proved. The prove run is completed when this volume or mass is reached. Unit [m3] in case of a volume flow meter, [tonne] in case of a mass flow meter.
Time per prove run	500	Only applicable if Master meter prove size type is set to 'Prove time'. Duration of the prove. The prove run is completed when this time [minutes] has passed.

Prove start command output

If the master meter flow computer is a multi module flow computer (X/P), the following settings are used to specify by which module the pulses are read.

Prove start DO module	1000	Only applicable if the Master meter proving type is set to 'Pulses'. Number of the module to which the Prove start digital output signal is physically connected.
Prove start DO channel	1000	Only applicable if the Master meter proving type is set to 'Pulses'. Channel number of the Prove start digital output signal.

Remote meter pulses

If the **Master meter proving type** is set to 'Pulses' and the meter on prove is on a remote module, the meter pulses have to be passed through from the meter module to the flow computer that runs the master meter prove logic. For that purpose on the meter module a digital channel has to be configured as 'Prover bus pulse out A' and a second digital channel has to be

configured as 'Prover bus pulse out B'. This output duplicates the meter pulses

Remote meter pulse input module	1000	Only applicable if the meter on prove is a remote meter while the Master meter proving type is set to 'Pulses'. In case of master meter proving of a remote meter the pulses from the meter on prove have to be passed through from the meter flow computer to the proving flow computer. This setting defines on which module on the prove flow computer the remote meter pulses are coming in. On the specified module the digital channel through which the pulse is coming in must be configured as ". Optionally also a 'Pulse input B' can be configured, which is used as a backup in case pulse input A fails.
Remote master meter pulse input module	1000	Only applicable if the master meter is a remote meter while the Master meter proving type is set to 'Pulses'. In case of master meter proving with a remote master meter the pulses from the master meter have to be passed through from the master meter flow computer to the proving flow computer. This setting defines on which module on the proving flow computer the remote meter pulses are coming in. On the specified module the digital channel through which the master meter pulse is coming in must be configured as 'Pulse input A'. Optionally also a 'Pulse input B' can be configured, which is used as a backup in case pulse input A fails.

Master meter proving with one module only

For master meter proving in principle separate modules are needed for the meter on prove and for the master meter. The prover flow computer contains or communicates to a number of meter modules, one of which can be used as the master meter. This means that for a master meter prove at least 2 modules are needed: one for the meter to be proved and one for the master meter. However, for special applications the Flow-X can be set up for master meter proving using one module only (with limited functionality). This is done by setting the **Master meter number** to 0.

In case of master meter proving with only one module, the following inputs are used:

Input signal	To be connected to
Meter pulse	Pulse input 1A (version 1 hardware) or Pulse input 1-4 (version 2 hardware)
Master meter pulse	Pulse input 1B (version 1 hardware) or Pulse input 1-4 (version 2 hardware)
Meter temperature	Meter temperature
Master meter temperature	Prover inlet temperature
Meter pressure	Meter pressure
Master meter pressure	Prover inlet pressure
Meter observed density	Meter observed density
Master meter observed density (if applicable)	Prover density
Meter density temperature (if applicable)	Meter density temperature
Master meter density temperature (if applicable)	Prover density temperature
Meter density pressure (if applicable)	Meter density pressure

Input signal	To be connected to
applicable)	
Master meter density pressure (if applicable)	Prover density pressure

When using master meter proving in one module only, the following restrictions apply:

- Only master meters that give pulses are supported: turbine meters, PD meters or the pulses from ultrasonic or coriolis meters.
- On version 1 hardware, only single pulses are supported both for the meter on prove and for the master meter. Dual pulses (both for the meter on prove and the master meter) are only supported on version 2 hardware.
- There's only one master meter K-factor. Forward / reverse K-factors and K-factor curves are **not** supported for the master meter.
- There's only one nominal master meter factor / error and one master meter factor / error curve. Forward / reverse meter factors and product specific meter factor / error curves are **not** supported for the master meter.
- Both master meter proving based on pulses and on totalizers are implemented (but the meter and master meter must both be pulse meters).
- Only meters of the same quantity type can be proved against each other: mass / mass or volume / volume. It's **not** possible to prove a mass meter against a volume master meter, or a volume meter against a mass master meter.
- Meter body correction on the master meter is **not** supported.
- Viscosity correction on the master meter is **not** supported.

Operational settings



Display → Configuration, Proving, Operational

The following settings are available for all types of proving (ball prover, compact prover, small volume prover, master meter proving).

Maximum nr of runs	500	The maximum number of prove runs allowed to achieve sufficient consecutive runs within the repeatability limit (1-10). If it is not possible to achieve sufficient consecutive runs within the remaining prove runs, the prove sequence may be aborted before the maximum nr. of runs is reached.
Passes per run	500	Only applicable to Brooks compact provers and Calibron / Flow MD small volume provers. Not applicable to master meter proving. The number of passes per run (1-10).
Required successful runs	500	Required number of consecutive runs within the repeatability limit before the prove sequence is completed successfully.
Double chronometry	500	Determines whether or not double-chronometry method of pulse interpolation is applied in accordance with API MPMS 4.6. 0: Disabled 1: Enabled API requires that pulse interpolation is performed when less than 5000 pulses are acquired within a single prove

	pass. This feature is typically enabled for compact provers and disabled for large volume pipe provers and master meter proving.
--	---

Run repeatability

Repeatability test method	500	Determines whether the repeatability calculation is based on pulse count or on the meter factor. Achieving repeatability based on meter factor might be more difficult to achieve, because the meter factor not only depends on the pulse count but also on the temperature, pressure, density etc. Repeatability is calculated as (max - min) / min * 100%. 1: Pulse count 2: Meter factor Setting not available for master meter proving (Repeatability test method is automatically set to 'Meter factor').
----------------------------------	-----	--

Run repeatability mode	500	The method to check whether sufficient consecutive runs are within the required repeatability limit. 1: Fixed (repeatability limit) The prove sequence is completed successfully when the Required successful runs have been performed consecutively within the 'Run repeatability limit'. 2: Progressive (uncertainty limit) The prove sequence is completed successfully when at least the Required successful runs have been performed consecutively within the repeatability limit that is in accordance with API 4.8 appendix A. API 4.8 app. A defines the repeatability limit as a function of the number or runs, such that the resulting uncertainty is lower than or equal to the configured uncertainty limit.
-------------------------------	-----	---

The commonly used uncertainty limit of 0.027% corresponds to the following repeatabilities:

Nr of runs	Repeatability limit [%]
3	0.02
4	0.03
5	0.05
6	0.06
7	0.08
8	0.09
9	0.10
10	0.12

Repeatability limit	500	The fixed repeatability limit [%] used if Run repeatability mode is set to 'Fixed'. Typical values are 0.05% for ball and compact provers and 0.02% for master meter proving, according to API 12.2.3.
----------------------------	-----	--

Uncertainty limit	500	The uncertainty limit [%] used if Run repeatability mode is set to 'Progressive'. Typical values are 0.027% and 0.073%, which correspond with 0.05% repeatability at respectively 5 and 3 prove runs (refer to API 4.8).
--------------------------	-----	--

Implement meter factor

Auto-implement new MF	500	Determines whether or not a new meter factor is implemented automatically at the end of a successful prove sequence, provided that the repeatability criteria are met and the meter factor tests have passed. 0: No 1: Yes
------------------------------	-----	--

MF manual accept timeout	500	The maximum allowable time [s] to manually accept a new meter factor after the prove sequence has ended successfully, provided that the repeatability criteria are met and the meter factors tests have passed. If the operator does not accept the new meter factor within this time limit, then the new meter factor is rejected automatically.
---------------------------------	-----	---

Prove permissive

A prove can only be started if the prove permissive is ON. Furthermore, a prove is aborted if the permissive switches to OFF while the prove sequence is active.

The prove permissive is ON if the following conditions are met:

- 4-way valve in auto control mode (bi-directional ball prover only)
- 4-way valve in remote control mode (bi-directional ball prover only; if applicable)
- 4-way valve in reverse position (bi-directional ball prover only)
- Low N2 alarm inactive (Brooks prover only)
- Communication to meter flow computer OK (when proving a remote run)
- Communication to master meter flow computer OK (in case of master meter proving using a remote master meter)
- Communication to remote prover IO server OK (if applicable)
- Custom prove permissive condition (optional)

Use proving permissive custom condition	1000	Determines whether or not the prove permissive custom condition is taken into account. If set to 'Yes' the prove permissive custom condition (to be written through Modbus or by a 'custom calculation') must be ON, otherwise the sequence can't be started or is aborted. 0: No 1: Yes
--	------	--

Prove integrity

A prove is aborted if the prove integrity switches to OFF while a prove is active.

The prove integrity is ON if the following condition is met:

- No 4-way valve leak detected (bi-directional ball prover only)
- Custom prove integrity condition (optional)

Use prove integrity custom condition	1000	Determines whether or not the prove integrity custom condition is taken into account. If set to 'Yes' the prove integrity custom condition (to be written through Modbus or by a 'custom calculation') must be ON while proving, otherwise proving is aborted. 0: No 1: Yes
---	------	---

Preliminary prove report

Preliminary prove report	1000	Defines if an extra, preliminary prove report is generated before the meter factor is accepted / rejected. This report can be used to decide whether or not to accept the meter factor. After acceptance / rejection the definitive report is generated. 0: Disabled 1: Enabled
---------------------------------	------	---

Stability check

 Display → Configuration, Proving, Stability check

Initial stability check	1000	Determines whether or not the initial stability check is performed. If enabled, the prove sequence only starts if the initial stability check has passed successfully. During the initial stability check the following process values are monitored: <ul style="list-style-type: none"> • Prover inlet temperature • Prover outlet temperature • Meter temperature • Prover inlet pressure • Prover outlet pressure • Meter pressure
--------------------------------	------	--

		<ul style="list-style-type: none"> Flow rate <p>In case of master meter proving the following process values are monitored:</p> <ul style="list-style-type: none"> Meter temperature Master meter temperature Meter pressure Master meter pressure Flow rate <p>The initial stability check passes as soon as all the process values do not change more than their corresponding limit during the required stabilization sample time (default 5 seconds). If the stability check has not passed during the max. stabilization time (default 30 sec.), then the prove sequence is aborted.</p>
Prove sequence stability check	1000	<p>Determines whether or not the deviation between:</p> <ul style="list-style-type: none"> Prover temperature (average) and meter temperature Prover pressure (average) and meter pressure <p>Or in case of master meter proving:</p> <ul style="list-style-type: none"> Master meter temperature and meter temperature Master meter pressure and meter pressure <p>is checked during proving. The check is only performed when the sphere / piston is between the detectors (i.e. in the calibrated volume).</p>
Max. stabilization time	1000	The maximum time [s] allowed for the initial stability check (default 30 seconds). If the stability check has not passed within this time, the prove sequence is aborted.
Stabilization sample time	1000	The sample time [s] for the initial stability check. The initial stability check passes as soon as the process values do not change more than their corresponding limit during this time.
Temperature change limit	1000	The maximum allowable temperature fluctuation [°C] during the initial stability check
Pressure change limit	1000	The maximum allowable pressure fluctuation [bar] during the initial stability check
Flow rate change limit	1000	The maximum allowable relative flow rate fluctuation [%] during the initial stability check
Max. temperature deviation prover/meter	1000	The maximum allowable deviation [°C] between the meter temperature and the prover temperature (average of inlet and outlet) c.q. master meter temperature
Max. pressure deviation prover/meter	1000	The maximum allowable deviation [bar] between the meter pressure and the prover pressure (average of inlet and outlet) c.q. master meter pressure

Meter factor tests

After completion of the last prove run, a number of tests is performed on the newly proved meter factor. The new factor is rejected automatically if one or more of these tests fail.



Display → Configuration, Proving, Meter factor tests

Meter factor limit test

Meter factor limit test	500	<p>Enables or disables the 'Meter factor limit test'.</p> <p>0: Disabled 1: Enabled</p> <p>The new meter factor is rejected if it is higher than the Meter factor high limit or lower than the Meter factor low limit, provided that the Meter factor limit test is enabled.</p>
Meter factor high limit	500	High limit [-] for the meter factor limit test
Meter factor low limit	500	Low limit [-] for the meter factor limit test

low limit		
Previous meter factor test		
Previous MF test	500	<p>Enables or disables the 'Previous meter factor test'.</p> <p>0: Disabled 1: Enabled</p> <p>The new meter factor is rejected if the deviation from the meter's previous proved meter factor exceeds the Previous MF deviation limit, provided that the Previous MF test is enabled.</p>
Previous MF deviation limit	500	Deviation limit [%] for the previous MF test

Historical meter factor test

Historical avg MF test	500	<p>Enables or disables the 'Historical average meter factor test'.</p> <p>0: Disabled 1: Enabled</p> <p>The application keeps track of the last 10 proved meter factors for each flow meter. The new meter factor is rejected if the deviation from the average of the last Nr of historical MF meter factors exceeds the Historical avg MF deviation limit, provided that the Historical average MF test is enabled.</p>
Historical avg MF deviation limit	500	Deviation limit [%] for the historical average MF test
Nr of historical MF avg	500	Number of historical meter factors (1-10) to be used for the historical average MF test

Base curve meter factor test

Base curve MF test	500	This test is only applicable if meter factor curve interpolation is enabled for the meter on prove.
Base curve MF deviation limit	500	Deviation limit [%] for the base curve MF test

Control Chart meter factor test

Control chart MF test	500	<p>Specifies whether the proved meter factor is checked against an API 13.2 control chart. For this test the flow computer maintains an API 13.2 control chart with the last 10 proved meter factors. Before accepting a new meter factor, it is added to the chart and a check is done against the selected probability range.</p>
Control chart MF test limits	500	<p>Specifies which limits are used to approve or reject the meter factor in a API 13.2 control chart check.</p> <p>1: Warning (90%) 2: Action (95%) 3: Tolerance (99%)</p>

Prove report

The 'Prove report' display contains the settings that define the number of decimal places for the meter factor and the intermediate correction factors. The display also contains settings that determine if the API truncating and rounding rules are applied for the calculation.



Display → Configuration, Proving, Prove report

API 12.2.3 Proving reports	1000	Determines whether prove reports should comply with the rounding, discrimination and calculation rules as per API MPMS 12.2.3.
----------------------------	------	--

compliance		0: Disabled 1: Enabled
API rounding proving	1000	Determines whether the rounding and truncating rules of the applicable API standard(s) are applied or not. 0: Disabled 1: Enabled Automatically enabled if 'API 12.2.3 Proving Reports' compliance is enabled.
Print accepted runs only	1000	Determines whether the prove report contains the results of all runs, or only the results of the accepted runs. 0: Disabled 1: Enabled

Decimal resolution

Intermediate meter factor decimal places	1000	Number of decimal places to which the intermediate meter factors, i.e. the meter factors calculated from the individual prove runs, are rounded. Set to 5 decimal places if API 12.2.3 proving reports compliance is enabled.
Meter factor decimal places	1000	Number of decimal places to which the (final) meter factor is rounded. Set to 4 decimal places if API 12.2.3 proving reports compliance is enabled.
Volume total decimal places	1000	Number of decimal places to which the metered and proved volumes [m ³] are rounded. API MPMS 12.2.3 prescribes 5 decimal places if value >=1, 6 if 0.1 <= value <1 and 7 if value <0.1. If API 12.2.3 proving reports compliance is enabled, the flow computer dynamically uses the appropriate number of decimals based on the actual volume total. The 'Base curve MF test' checks if the deviation between the proved meter factor and the 'meter factor determined from the meter factor curve at the proved flow rate' is not larger than the 'Base curve MF deviation limit'. The meter factor is rejected if the test fails.
Mass total decimal places	1000	Number of decimal places to which the proved and metered masses [tonne] are rounded. API MPMS 5.6 prescribes 4 decimal places if value >=10, 5 if 1 <= value <10 and 6 if value <1. If API 12.2.3 proving reports compliance is enabled, the flow computer dynamically uses the appropriate number of decimals based on the actual mass total.
CTS decimal places	1000	Number of decimal places to which the correction factor for the influence of temperature on the prover steel (Ctsp) is rounded. Set to 5 decimal places if API 12.2.3 proving reports compliance is enabled. Not applicable to master meter proving.
CPS decimal places	1000	Number of decimal places to which the correction factor for the influence of pressure on the prover steel (Cpsp) is rounded. Set to 5 decimal places if API 12.2.3 proving reports compliance is enabled. Not applicable to master meter proving.
CTL decimal places	1000	Number of decimal places to which the correction factors for the influence of temperature on the liquid in the prover (Ctlp) and in the meter (CtIm) are rounded. Set to 5 decimal places if API 12.2.3 proving reports compliance is enabled.
CPL decimal places	1000	Number of decimal places to which the correction factors for the influence of pressure on the liquid in the prover (Cplp) and in the meter (Cplm) are rounded.

		Set to 5 decimal places if API 12.2.3 proving reports compliance is enabled.
CCF (CTPL) decimal places	1000	Number of decimal places to which the combined correction factors for the prover (CCFp) and the meter (CCFm) are rounded. Set to 5 decimal places if API 12.2.3 proving reports compliance is enabled.
Density decimal places	1000	Number of decimal places to which the density [kg/m ³] is rounded. Only used in case of inferred mass proving or master meter proving of volume vs. mass. API MPMS 5.6 prescribes 2 decimal places. Set to 2 decimal places if API 12.2.3 proving reports compliance is enabled.

Meter runs

This display page gives an overview of the meter runs that are involved in proving.



Display → Configuration, Proving, Meter runs

Run <x>

Remote run device nr.	1000	Device nr. of the remote run flow computer as defined in Flow-Xpress 'Ports & devices'. If a valid remote run device nr. is selected (i.e. if in Flow-Xpress this device nr. has been assigned to a remote run communication device), the run will be designated as 'Remote'. If 'No Device' is selected, the run is either designated as 'Local' or as 'None', depending on the physical flow computer hardware.
-----------------------	------	---

System time deviation

These settings are only applicable if the flow computer is communicating to one or more remote run flow computers.

Remote run max. system time deviation	1000	If the system time of a remote run module differs from the system time of the station module by more than this amount [s], then a 'System time out of sync alarm' is generated.
Delay for system time out of sync alarms	1000	System time out of sync alarms only become active after the deviation has been larger than the 'max. deviation' during the delay time [s].

Loading

Optionally, the Liquid_Metric application can be extended with loading functionality.

Loading setup

The loading configuration displays are only available on applications that contain additional loading functionality with **loading** parameter set to enabled (display → Configuration, Overall setup, Common settings, Loading).



Display → Configuration, Run <x>, Loading, Loading setup

with <x> the number of the meter run

Loading setup

Flow control valve type	1000	<p>Defines the type of control valve that is controlled by the flow computer</p> <p>0: None</p> <p>No flow control</p> <p>1: Analog flow control valve Flow control through analog control valve connected to an analog output of the flow computer*</p> <p>2: Digital control valve Flow control through digital control valve ('set-stop valve') using 'clicks'**.</p> <p>4: Two-stage OCV 115-5 Flow control through two-stage valve using 2 solenoids for high / low flow</p> <p>5: Two-stage ISE/N 2SLR Flow control through two-stage valve using 2 solenoids for high / low flow</p> <p>* Requires configuration of the run flow control valve (Display → Configuration, Run <x>, Flow control). The following settings of the run flow control valve are automatically set if 'analog flow control valve' is selected:</p> <ul style="list-style-type: none"> - Flow / pressure control mode = 'Flow control' - Flow control input = 'Gross volume' or 'Mass', depending on the configured batch quantity type. <p>** Special connection needed including one or more relays</p>
Inlet valve control	1000	<p>Enables / disables automatic control of the inlet block valve</p> <p>0: Disabled</p> <p>1: Enabled</p> <p>Requires configuration of the run inlet valve (Refer to paragraph 'Valve control').</p>
Outlet valve control	1000	<p>Enables / disables automatic control of the outlet block valve</p> <p>0: Disabled</p> <p>1: Enabled</p> <p>Requires configuration of the run outlet valve (Refer to paragraph 'Valve control').</p>
Auto batch end	1000	<p>Automatically finishes a load if the status becomes 'Completed' or when loading is aborted and not restarted within the 'Loading restart time'. If 'Auto batch end' is disabled, a manual 'Finish loading' command has to be given to close the batch.</p> <p>0: Disabled</p> <p>1: Enabled</p>
Loading aborted alarms	1000	<p>If enabled, alarms are generated and logged when loading is aborted. If disabled, loading is aborted without generating alarms.</p> <p>0: Disabled</p>

Unauthorized flow detection	1000	<p>1: Enabled</p> <p>If enabled, an alarm is generated if the meter gets active while the loading sequence is idle.</p> <p>0: Disabled</p> <p>1: Enabled</p>
Abort loading if batch size reached	1000	<p>Enable if the loading has to be aborted when the preset quantity has been loaded (to avoid overflow).</p> <p>0: Disabled</p> <p>1: Enabled</p>
Calculation based on shake out	1000	<p>Enables recalculation based on manually entered BS&W and / or standard density value</p> <p>0: Disabled</p> <p>1: Enabled</p> <p>This creates the possibility to enter data from sample analysis. Any BS&W or standard density values measured during loading are overridden by manually entered values.</p> <p>Prerequisites</p> <ul style="list-style-type: none"> - Station recalculation disabled - Recalculated report enabled
Loading control displays	1000	<p>Several displays are available for loading control.</p> <p>0: Generic</p> <p>1: Truck driver</p> <p>2: Truck driver – loading data</p> <p>3: Transloader displays</p>
Rack number	1000	<p>In case of multiple racks, this defines the rack to which this loading run belongs</p>

Loading start DI

Configures an optional digital input to receive a loading start command from the field.

Start loading DI module	1000	<p>Number of the flow module to which the input signal is physically connected.</p> <p>-1: Local module means the module of the meter run itself</p>
Start loading DI channel	1000	<p>Number of the digital channel on the selected module to which the input signal is physically connected.</p> <p>Enter '0' to un-assign the start loading digital input.</p>

Loading stop DI

Configures an optional digital input to receive a loading stop command from the field.

Stop loading DI module	1000	<p>Number of the flow module to which the input signal is physically connected.</p> <p>-1: Local module means the module of the meter run itself</p>
Stop loading DI channel	1000	<p>Number of the digital channel on the selected module to which the input signal is physically connected.</p> <p>Enter '0' to un-assign the stop loading digital input.</p>

Loading finish DI

Configures an optional digital input to receive a loading finish command from the field.

Finish loading DI module	1000	<p>Number of the flow module to which the input signal is physically connected.</p> <p>-1: Local module means the module of the meter run itself</p>
Finish loading DI channel	1000	<p>Number of the digital channel on the selected module to which the input signal is physically connected.</p> <p>Enter '0' to un-assign the finish loading digital input.</p>

Emergency shutdown DI

Configures an optional digital input to receive an emergency shutdown command from the field.

Emergency shutdown DI module	1000	Number of the flow module to which the input signal is physically connected. -1: Local module means the module of the meter run itself
Emergency shutdown DI channel	1000	Number of the digital channel on the selected module to which the input signal is physically connected. Enter '0' to un-assign the emergency shutdown digital input.

Pump start DO

Configures an optional digital output to start a pump.

Pump start DO	1000	Enables a pump start command sent through a digital output. 0: Disabled 1: Enabled
Pump start DO module	1000	Number of the flow module to which the output signal is physically connected. -1: Local module means the module of the meter run itself
Pump start DO channel	1000	Channel number of the pump start digital output signal

Flow active DO

Configures an optional digital output to indicate that flow is active.

Flow active DO	1000	Enables flow active indication through a digital output. 0: Disabled 1: Enabled
Flow active DO module	1000	Number of the flow module to which the output signal is physically connected. -1: Local module means the module of the meter run itself
Flow active DO channel	1000	Channel number of the flow active digital output signal

BS&W alarm DO

Configures an optional digital output to indicate a BS&W alarm.

BS&W alarm DO	1000	Enables indication of a BS&W alarm through a digital output. 0: Disabled 1: Enabled
BS&W alarm DO module	1000	Number of the flow module to which the output signal is physically connected. -1: Local module means the module of the meter run itself
BS&W alarm DO channel	1000	Channel number of the BS&W alarm digital output signal

Meter failed status DO

Configures an optional digital output to indicate a meter failure.

Meter failed status DO	1000	Enables indication of meter failure through a digital output. 0: Disabled 1: Enabled
Meter failed status DO module	1000	Number of the flow module to which the output signal is physically connected. -1: Local module means the module of the meter run itself
Meter failed	1000	Channel number of the meter failed status digital

status DO channel	output signal
-------------------	---------------

Loading permissive DO

Configures an optional digital output to indicate loading permissive.

Loading permissive DO	1000	Enables indication of loading permissive through a digital output. 0: Disabled 1: Enabled
Loading permissive DO module	1000	Number of the flow module to which the output signal is physically connected. -1: Local module means the module of the meter run itself
Loading permissive DO channel	1000	Channel number of the loading permissive digital output signal

Exsite

Configures driver authorization with Exsite software.

Driver authorization	1000	Enables driver authorization using Exsite software. 0: Disabled 1: Enabled
Authorization timeout limit	1000	Defines the maximum period [s] that a driver can be logged in. Automatically logs out the driver if the login period has exceeded this limit, irrespective if a loading is active or not
Communication timeout limit	1000	The driver is automatically logged out if communication with the Exsite software has been failing for this period [s].

Loading operational settings



Display → Configuration, Run <x>, Loading, Operational with <x> the number of the meter run

Loading amount

Batch size	500	Amount of product to be loaded. Volume [m3] or mass [tonne], depending on the batch quantity type .
Low flow at start amount	500	Amount of product that will be loaded at the low flow rate in the 'low flow at start' stage. After this amount has been loaded, the procedure continues to the 'high flow' stage. Volume [m3] or mass [tonne], depending on the batch quantity type . Enter 0 to disable low flow at startup. The loading will then be started directly at high flow rate, skipping the 'low flow at start' stage.
Low flow at end amount	500	Amount of product that will be loaded at the low flow rate in the 'low flow at end' stage. The procedure switches from the 'high flow' to the 'low flow at end' stage if the actual batch amount equals the batch size minus the low flow at end amount . Volume [m3] or mass [tonne], depending on the batch quantity type . Enter 0 to disable low flow at end. The loading will then be ended directly from high flow rate, skipping the 'low flow at end' stage.
Early end amount	500	Early end amount to account for the time needed to stop the flow. Volume [m3] or mass [tonne], depending on the batch quantity type . The valve close command will be issued when the

actual loaded amount equals the **batch size** minus the **early end amount**.

Loading setpoints

Low flow rate setpoint	500	Flow setpoint for the 'low flow at start' and 'low flow at end' stages. Volume flow rate [m3/h] or mass flow rate [tonne/h], depending on the batch quantity type .
High flow rate setpoint	500	Flow setpoint for the 'high flow' stage. Volume flow rate [m3/h] or mass flow rate [tonne/h], depending on the batch quantity type .
Margin for low flow rate check	500	Margin [%] Loading will be aborted if the flow rate doesn't reach the low flow rate +/- this margin within the Maximum allowable time to reach low flow (on entering the 'low flow at start' and 'low flow at end' stages).
Margin for high flow rate check	500	Margin [%] Loading will be aborted if the flow rate doesn't reach the high flow rate minus this margin within the Maximum allowable time to reach high flow (on entering the 'high flow' stage).

Loading timing

Open control valve delay time	500	Delay time [s] for opening the control valve after the start command / pump start / opening of the block valve(s). Enter 0 to disable the delay.
Maximum allowable time to reach start low flow	500	Timeout time [s] for checking whether the low flow rate is reached on entering the 'low flow at start' stage. If the flow rate doesn't reach the low flow setpoint minus the margin for low flow rate check in time, loading is aborted. Enter 0 to disable this function.
Maximum allowable time to reach high flow	500	Timeout time [s] for checking whether the high flow rate is reached on entering the 'high flow' stage. If the flow rate doesn't reach the high flow setpoint minus the margin for high flow rate check in time, loading is aborted. Enter 0 to disable this function.
Maximum allowable time to reach end low flow	500	Timeout time [s] for checking whether the low flow rate is reached on entering the 'low flow at end' stage. If the flow rate doesn't reach the low flow setpoint plus the margin for low flow rate check in time, loading is aborted. Enter 0 to disable this function.
Maximum allowable time to stop the flow	500	Timeout time [s] for checking whether no flow condition is reached at closing of the loading. If the flow rate doesn't reach zero flow in time, loading is aborted. Enter 0 to disable this function.
Pump shutdown delay time	500	Delay time [s] for shutdown of the pump / closing of the block valve(s) after the control valve has been closed (during a normal stop).
Restart loading timeout time	500	Only applicable if auto batch end enabled. Maximum time [s] for restarting loading after an abort or a stop loading command. If a (re-)start command has not been issued within this time the loading will be finished.
Deadband time on permissive abort	500	Maximum time [s] that a no permissive condition is allowed to be present before loading is aborted.
Deadband time on meter inactive abort	500	Maximum time [s] that a meter inactive condition is allowed to be present before loading is aborted.

Loading data entry

In this section, data entry fields can be specified that need to be entered before loading can be started. Data entered here will be stored with the loading data.



Display → Configuration, Run <x>, Loading, Loading data entry

with <x> the number of the meter run

The following data fields can be enabled / disabled. All data fields that are enabled must be entered before loading can be started.

Truck information

Driver number
Driver name
Trucking company
Truck number
Trailer number

Lease and operator information

Lease operator name
Lease name
Lease number
Ticket operator number

Ticket information

Ticket number
Observed volume
Observed BS&W
Observed density
Observed pressure
Observed temperature

Customer information

Customer number	
Multiple customers	When enabled, a customer number has to be selected for each load. When disabled the customer number is set to 1.

Product data

Product number	This number is copied to the batch product number and is used to select the correct API table / calculation standard.
----------------	---

Batch data

Batch ID	
Batch size	Volume [m3] or mass [tonne], depending on the batch quantity type .

Sampler data

Sample can number	This number is used by the flow computer to select the sample can.
-------------------	--

Custom loading data

In this section, up to 25 additional free configurable data fields can be defined.

Loading data entry [x] description	Description of the data field as it will be shown on the data entry display.
Data entry [x] required	Specifies whether or not this data field has to be entered before loading is started.

Loading permissives

In this section, loading permissives can be specified, which have to be fulfilled before loading can be started. If a permissive is not met during loading, loading will be aborted, taking into account the **Deadband time on permissive abort**.



Display → Configuration, Run <x>, Loading, Loading permissives

with <x> the number of the meter run

The following permissives can be configured.

Loading ground DI

Load ground input enabled	1000	If enabled the loading ground must be connected, otherwise the loading can't be started or is aborted. 0: Disabled 1: Enabled
Load ground digital input module	1000	Number of the flow module to which the input signal is physically connected. -1: Local module means the module of the meter run itself
Load ground digital input channel	1000	Channel number of the Load ground digital input signal
Load ground input text	1000	Text that is shown to the user if loading is not permitted because load ground is OFF.

Permissive digital inputs 1-4

Up to four custom permissive digital inputs can be configured.

Permissive input [1-4] enabled	1000	If enabled the permissive input must be ON, otherwise the loading can't be started or is aborted. 0: Disabled 1: Enabled
Permissive DI [1-4] module	1000	Number of the flow module to which the input signal is physically connected. -1: Local module means the module of the meter run itself
Permissive DI [1-4] channel	1000	Channel number of the Permissive digital input signal
Permissive input [1-4] text	1000	Text that is shown to the user if loading is not permitted because the permissive input is OFF.

BS&W permissive

During loading, the actual BS&W value can be monitored, aborting the loading if the value gets too high. Additionally, a user can be temporarily 'locked out' after repeated aborts.

BS&W permissive enabled	1000	If enabled the BS&W must be below the BS&W permissive high limit , otherwise the loading can't be started or is aborted. 0: Disabled 1: Enabled
BS&W permissive high limit	1000	Generic BS&W high limit [%] that is used if can specific BS&W limits are disabled.
BS&W high alarm delay	1000	Delay time [s] on BS&W permissive and alarm. The permissive is withdrawn if the actual BS&W value is above the limit for more than this time.
BS&W user lockout	1000	If enabled, a user will be locked out if loading has been aborted twice due to high BS&W. The locked out user can't start another loading until the 'BS&W lock time' has passed. 0: Disabled 1: Enabled
BS&W lock time	1000	During this time [s] a locked out user can't start another loading.

Can BS&W permissives

Can specific BS&W high limits	1000	Enable to use individual can high BS&W alarm limits. When disabled, the (generic) BS&W permissive high limit value is used. 0: Disabled 1: Enabled
Can 1-16 BS&W high limit	1000	BS&W high limit [%] for can 1-16. This limit is used for the BS&W permissive if can specific BS&W high limits are enabled and the corresponding sample can is selected.

Custom permissives

Three custom permissives that can be written through communication or through a 'user calculation'.

Use custom permissive [1-3]	1000	If set to 'Yes', custom permissive 1 (to be written through Modbus or by a 'custom calculation') must be ON, otherwise the loading can't be started or is aborted. 0: No 1: Yes
Custom permissive [1-3] description	1000	Description of the permissive as shown on the display.
Custom permissive [1-3] text	1000	Text that is shown to the user if loading is not permitted because the custom permissive is OFF.

Booster pump

Settings for configuration of an additional booster pump. Both fixed and variable booster pumps are supported.



Display → Configuration, Run <x>, Loading, Booster pump

with <x> the number of the meter run

Booster pump digital output

Booster pump DO	1000	Enable if a booster pump must be started with a start command (using a digital output). 0: Disabled 1: Enabled
Booster pump DO module	1000	Number of the flow module to which the booster pump start signal is physically connected. -1: Local module means the module of the meter run itself
Booster pump DO channel	1000	Channel number of the Booster pump start digital output signal

Booster pump analog output

Booster pump AO	1000	Enable in case of a variable booster pump (using an analog output; setpoint as a function of density). 0: Disabled 1: Enabled
Booster pump AO module	1000	Number of the flow module to which the booster pump analog signal is physically connected. -1: Local module means the module of the meter run itself
Booster pump AO channel	1000	Channel number of the Booster pump analog output signal

Booster pump settings

Booster pump start delay	1000	The booster pump starts after the main pump has been started using this delay [s]. Applicable to fixed and variable booster pumps
Booster pump stabilization time	1000	Initially, the booster pump will run at the stabilization setpoint during this time [s], in order to allow the density to stabilize. When the stabilization

		time is elapsed the booster pump switches over to the setpoint from the booster pump setpoint curve. Only applicable to variable booster pump
Booster pump stabilization setpoint	1000	Setpoint [mA] for the booster pump during initial stabilization.

Booster pump setpoint curve

Setpoint curve for variable booster pump. Analog output level as a function of measured density. Maximum 5 output levels can be configured (4 density limits). Density limits must be in ascending order. A density limit of 0 disables the remainder of the curve, making it possible to use a curve with less than 5 output levels.

Booster pump setpoint 1 – AO setpoint	1000	Analog output value [mA] for density below density limit 1.
Booster pump setpoint 1 - density limit	1000	Density limit [kg/m3] for switching between AO setpoint 1 and 2. Lowest density limit. Density limits must be in ascending order.
Booster pump setpoint 2 - AO setpoint	1000	Analog output value for density above density limit 1 but below density limit 2.
Booster pump setpoint 2 - density limit	1000	Density limit [kg/m3] for switching between AO setpoint 2 and 3.
Booster pump setpoint 3 - AO setpoint	1000	Analog output value for density above density limit 2 but below density limit 3.
Booster pump setpoint 3 - density limit	1000	Density limit [kg/m3] for switching between AO setpoint 3 and 4.
Booster pump setpoint 4 - AO setpoint	1000	Analog output value for density above density limit 3 but below density limit 4.
Booster pump setpoint 4 - density limit	1000	Density limit [kg/m3] for switching between AO setpoint 4 and 5.
Booster pump setpoint 5 - AO setpoint	1000	Analog output value for density above density limit 4.

Product evaluation

This section contains configuration of control of a divert valve to divert off-spec product to a separate tank.



Display → Configuration, Run <x>, Loading, Product evaluation

with <x> the number of the meter run

Divert valve control mode	1000	Defines how the logic reacts on the value of the product evaluation variable 0: None 1: Divert if above limit 2: Divert if below limit 3: Divert if out of range 4: Divert if within range Select 'None' to disable this functionality
Product evaluation variable	1000	Variable that is used for product evaluation. 1: Observed density 2: Standard density 3: Driver density 4: Observed BS&W 5: Custom value
Product	1000	Product evaluation will only be active if the actual

evaluation threshold flow rate		flow rate is higher than this threshold flow rate [m3/hr]. Only applicable if the divert valve is located downstream of the meter. If the divert valve is located upstream of the meter, product evaluation remains active at low flow.
Product divert valve location	1000	Location of the divert valve relative to the meter 1: Upstream of meter 2: Downstream of meter
Product divert valve configuration	1000	Defines what must happen to the divert valve to divert the product 1: Open valve to divert 2: Close valve to divert
Product divert delay time	1000	The number of seconds to wait for the density / BS&W to stabilize before diverting the product.

Product evaluation limit

Switching limit	1000	Only applicable to divert valve control modes 'divert above limit' and 'divert below limit'. The limit at which the divert valve will switch. Units are the same as the product evaluation variable .
-----------------	------	---

Product evaluation range

Switching range high limit	1000	Only applicable to divert valve control modes 'divert if out of range' and 'divert if within range'. High range value Units are the same as the product evaluation variable .
Switching range low limit	1000	Only applicable to divert valve control modes 'divert if out of range' and 'divert if within range'. Low range value Units are the same as the product evaluation variable .

Product off-spec abort

Maximum allowable time for product divert	1000	Loading will be aborted if the divert valve is activated for more than this time [s].
---	------	---

Divert valve control

For configuration of the divert valve, please refer to paragraph 'valve control'.



Display → Configuration, Run <x>, Loading, Divert valve

with <x> the number of the meter run

Digital flow control valve

Settings for configuring a digital control valve / 'set-stop valve'.



Display → Configuration, Run <x>, Loading, Digital control valve

with <x> the number of the meter run

This display is only available if the **flow control valve type** is set to 'digital flow control valve'.

The logic makes use of a 'control band' and a narrower 'deadband'. If the flow rate is outside the control band, the solenoids are controlled by continuous signals, causing a quick movement of the valve in the direction of the flow setpoint. As

soon as the actual flow gets within the control band, the solenoids are controlled by ‘clicks’, short pulses that make the valve move slowly to the setpoint. When the flow is within the deadband, control is stopped and the valve is fixed close to the setpoint in order to avoid frequent clicks.

Digital control valve – Input mode	600	Actual flow rate value used as process value for flow control 1: Gross volume Controls the gross volume flow rate [m3/hr] 2: Gross standard volume Controls the gross standard volume flow rate [sm3/hr] 3: Mass Controls the mass flow rate [tonne/hr] 4: Custom The value that is written to the tag Flow control - Custom process value will be used. Use this option if the flow rate value is sent to the flow computer over a Modbus communications link or if you want to apply user-defined calculations to the flow rate to be used for flow control. Please make sure your selection is in line with the selected batch quantity type (volume or mass, display: Configuration, Overall setup, Common settings)
Digital flow control - Maximum open time		Maximum time [s] that the system tries to reach the setpoint. If the setpoint is not reached within this time, the system fixes the flow rate at the actual value.

Clicks setup

Configuration of the ‘clicks’: short pulses to slowly adjust the valve position in control mode.

Digital flow control - Open clicks interval	600	Time between clicks [s] for slowly controlling the valve to open.
Digital flow control - Open click duration	600	Duration of the clicks [ms] for slowly controlling the valve to open.
Digital flow control - Close clicks interval	600	Time between clicks [s] for slowly controlling the valve to close.
Digital flow control - Close click duration	600	Duration of the clicks [ms] for slowly controlling the valve to close.

Upstream solenoid

Configuration of the upstream solenoid.

Upstream (NO) solenoid DO module	600	Number of the flow module to which the signal is physically connected. -1: Local module means the module of the meter run itself
Upstream (NO) solenoid DO channel	600	Channel number of the Upstream solenoid digital output signal
Upstream (NO) solenoid pulse output nr.	600	Pulse output number on the specified module that is used for the upstream solenoid clicks. 1: Pulse output 1 2: Pulse output 2 3: Pulse output 3 4: Pulse output 4

Downstream solenoid

Configuration of the downstream solenoid.

Downstream (NC)	600	Number of the flow module to which the signal is
-----------------	-----	--

solenoid DO module		physically connected. -1: Local module means the module of the meter run itself
Downstream (NC) solenoid DO channel	600	Channel number of the Downstream solenoid digital output signal
Downstream (NC) solenoid pulse output nr.	600	Pulse output number on the specified module that is used for the downstream solenoid clicks. 1: Pulse output 1 2: Pulse output 2 3: Pulse output 3 4: Pulse output 4

Deadband

Digital flow control - Deadband	600	No clicks will be issued and the valve will be fixed if the actual flow rate is between the setpoint value minus the deadband and the setpoint value plus the deadband. Units are the same as the flow rate units.
---------------------------------	-----	---

Control band

Digital flow control – Control band	600	If the actual flow rate is within the control band, but outside of the deadband, flow will be controlled using open / close clicks. Units are the same as the flow rate units. For correct functioning, the control band has to be set wider than the deadband.
-------------------------------------	-----	---

Two-stage control valve

Settings for configuring a two-stage control valve OCV 115-5 (‘Two Stage Preset Valve’) or ISE/N 2SLR (‘Automatic Valve’). These valves are technically similar to digital control valves, but don’t require ‘clicks’ to be issued by the flow computer.



Display → Configuration, Run <x>, Loading, Two-Stage control valve

with <x> the number of the meter run

This display is only available if the **flow control valve type** is set to ‘Two-stage OCV 115-5’ or ‘Two-stage ISE/N 2SLR’.

In both cases, 2 digital outputs are used to control the valve. With valve type ISE/N 2SLR, the flow computer digital outputs are directly connected to the upstream and downstream solenoids. With valve type OCV 115-5, the digital outputs are connected to two intermediate switches SW1 and SW2.

Low flow solenoid open time	500	Only applicable to valve type OCV 115-5 Time to open SW1 in order to reach low flow at start.
-----------------------------	-----	--

Upstream solenoid / SW1

Upstream solenoid / SW1 DO module	600	Number of the flow module to which the upstream solenoid (ISE/N 2SLR) or SW1 (OCV 115-5) is physically connected. -1: Local module means the module of the meter run itself
Upstream solenoid / SW1 DO channel	600	Channel number of the upstream solenoid (ISE/N 2SLR) or SW1 (OCV 115-5) digital output signal

Downstream solenoid / SW2

Downstream	600	Number of the flow module to which the
------------	-----	--

solenoid / SW2 DO module	downstream solenoid (ISE/N 2SLR) or SW2 (OCV 115-5) is physically connected.
	-1: Local module means the module of the meter run itself
Downstream solenoid / SW2 DO channel	600 Channel number of the downstream solenoid (ISE/N 2SLR) or SW2 (OCV 115-5) digital output signal

Metrological settings

The Flow-X features accountable and non-accountable totalizers, in order to split the metered amount into an accountable amount (measured while there was no accountable alarm) and a non-accountable amount (measured while there was an accountable alarm).

This functionality is enabled by the setting **MID compliance** on the display: Configuration, Overall setup, Common settings.

If there is no accountable alarm then the accountable totalizers are active and the non-accountable totalizers are inactive. In case of an accountable alarm the non-accountable totalizers are active and the accountable totalizers are inactive. The normal totalizers are active regardless of the accountable alarm.



Display → Configuration, Metrological, Run <x>
with <x> the number of the meter run

This display is only visible if **MID compliance** (Configuration, Overall setup, Common settings) is enabled.

Batch size

Minimum accountable batch size	1000	If the previous batch total is below this limit then a **Batch size below accountable minimum** indication is printed on the batch report. There are two separate settings, one for a volumetric check [m3] and one for a mass check [tonnes]. By entering a value 0 either check may be disabled.
--------------------------------	------	--

Flow rate

Meter minimum accountable flow rate	1000	Low range value (minimum allowable flow rate) of the flow rate. Unit [m3/hr] in case of a volume flow meter, [tonne/hr] in case of a mass flow meter. If the flow rate is below this value then the 'Flow range accountable alarm' is raised.
Meter maximum accountable flow rate	1000	High range value (maximum allowable flow rate) of the flow meter. Unit [m3/hr] in case of a volume flow meter, [tonne/hr] in case of a mass flow meter. If the flow rate is above this value then the 'Flow range accountable alarm' is raised.

Temperature

Minimum accountable temperature	1000	Minimum allowable temperature [°C]. If the temperature is below this value then the 'Temperature accountable alarm' is raised.
Maximum accountable temperature	1000	Maximum allowable temperature [°C]. If the temperature is above this value then the 'Temperature accountable alarm' is raised.

Pressure

Minimum accountable pressure	1000	Minimum allowable pressure [bar(a)]. If the pressure is below this value then the 'Pressure accountable alarm' is raised.
Maximum accountable pressure	1000	Maximum allowable pressure [bar(a)]. If the pressure is above this value then the 'Pressure accountable alarm' is raised.

Standard density

Minimum accountable standard density	1000	Minimum allowable standard density. If the standard density is below this value then the 'Standard density accountable alarm' is raised.
Maximum accountable standard density	1000	Maximum allowable standard density. If the standard density is above this value then the 'Standard density accountable alarm' is raised.
Equilibrium pressure accountable alarm limit	1000	An 'equilibrium pressure accountable alarm' is generated if the pressure is below the equilibrium pressure plus this offset [bar].

Accountable alarm neutralization

Accountable alarm neutralization	1000	Enables the neutralization amount on flow range, temperature range, pressure range and standard density range accountable alarms. 0: Disabled 1: Enabled
Low flow alarm neutralization quantity	1000	Amount of product that is measured between the moment that a low flow alarm condition becomes active and the moment that the alarm actually is activated. [m3] in case of a volume flow meter, [tonne] in case of a mass flow meter
Low flow alarm neutralization reset quantity	1000	The Low flow neutralization counter is reset when this quantity is reached without any low flow alarm. [m3] in case of a volume flow meter, [tonne] in case of a mass flow meter
Accountable alarm neutralization quantity	1000	Amount of product that is measured between the moment that a temperature range, pressure range, standard density range or high flow accountable alarm condition becomes active and the moment that the alarm actually is activated. [m3] in case of a volume flow meter, [tonne] in case of a mass flow meter
Accountable alarm neutralization reset quantity	1000	The Neutralization counter is reset when this quantity is reached without any temperature range, pressure range, standard density range or high flow accountable alarm. [m3] in case of a volume flow meter, [tonne] in case of a mass flow meter

5 Maintenance mode

Maintenance mode is a special mode of operation intended for testing the flow computer functionality, typically its calculations. Maintenance mode can be enabled and disabled for each meter run separately.

Maintenance mode is the same as normal operation mode except that in Maintenance Mode all the custody transfer totals are inhibited. Instead flow is accumulated in separate Maintenance totals. Optionally the maintenance totals automatically reset each time maintenance mode is enabled (setting **Reset maint. totals on entering maint. mode** on display: Configuration, Common settings).

A permissive flag is used to enter and exit maintenance mode. By default the flag is always 1, i.e. it is always permitted to enter/exit maintenance mode. However the permissive flag may be controlled by custom-made logic through 'User Calculations' in Flow-Xpress, e.g. to inhibit entering/exiting maintenance mode if the meter is active.

Optionally, process alarms and calculation alarms are disabled, when in maintenance mode (setting **Disable alarms in maintenance mode** on display: Configuration, Common settings).

Maintenance mode should be disabled for normal operation.

A 'Maintenance mode enabled' alarm is generated when the meter is in maintenance mode.



Display →Maintenance mode, Run <x>

with <x> the number of the flow module that controls the flow meter

Enable maint mode	1000	Enter maintenance mode. Only allowed if Maint mode switch permissive is ON.
Disable maint mode	1000	Exit maintenance mode. Only allowed if Maint mode switch permissive is ON.

6 Calculations

This chapter specifies the main calculations performed by the Liquid Metric application.



Calculations in compliance with a measurement standard, such as API-2540 and GPA TP-27, are not specified in this manual. Please refer to the standards for more details on these calculations.

API Petroleum Measurement Tables

The first version of the API Petroleum Measurement Tables was published in **1952**. In those days measurement readings were taken manually and the tables were used to convert the observed density at the observed temperature to the value at the reference temperature. So the table values were the actual standard.

The 1952 Tables consists of 58 tables containing all kinds of correction and conversion factors used in the measurement of hydrocarbon liquids. Each table deals with a particular conversion of units, correction of density, or correction of volume. The 1952 tables that are related to the conversion of density and volume are: 5, 6, 23, 24, 53 and 54.

Tables 5, 6, 23 and 24 convert density or volume to or from a reference temperature of 60°F. Tables 53 and 54 use a reference temperature of 15°C.

In **1980** a complete new set of tables was published together with computer routines to allow electronic devices to automatically calculate the volume conversion factors and API gravity / (relative) density at the reference temperature. Back then most electronic devices were not capable of performing double-precision floating point calculations, so the standard prescribed all kinds of rounding and truncating rules to make sure that the calculations would always provide the same result. For the 1980 version the calculation procedures are the standard rather than the table values.

In the 1980 version, which is also referred to as **API-2540**, the tables are divided into 3 product groups and a character designation was used to distinguish between the sub-tables. "A" was used for crude oil, "B" for refined products and "C" for special applications. The 1980 tables, however, did not cover the LPGs and NGLs density ranges and the 1952 Tables were left valid for these products. Furthermore, the lubricating oil tables (designated as "D") were not complete at the time of the printing in 1980 and were released two years later. As opposed to the A, B and C tables no implementation procedures were defined for the D tables.

In 1988 the Institute of Petroleum released its Paper No. 3 with tables 59 and 60 that are based on a reference temperature of 20°C.

This resulted in the following Petroleum Measurement Tables dealing with the conversion of volume and density to and from a reference temperature.

Number	Title
5	API Gravity Reduction to 60°F
6	Reduction of Volume to 60°F against API Gravity at 60°F
23	Reduction of Observed Specific Gravity to Specific Gravity 60/60°F
24	Reduction of Volume to 60°F against Specific Gravity 60/60°F
53	Reduction of Observed Density to Density at 15°C
54	Reduction of Volume to 15°C against Density at 15°C
59	Reduction of Observed Density to Density at 20°C
60	Reduction of Volume to 20°C against Density at 20°C

In **2004** the API MPMS 11.1 1980 tables were superseded by a new set of tables primarily for the following reasons:

- API 11.1:2004 includes the correction for both temperature and pressure in one and the same algorithm
- Taken into account the progress in electronics (and for other reasons) the complex truncating and rounding rules were abandoned. Instead the calculation procedures use double-precision floating point math. The input and output values are still rounded in order to obtain consistent results.
- The convergence methods for the correction of observed density to standard density have been improved.
- On-line density measurement by densitometers became common practice, requiring the pressure and temperature correction to be incorporated in one and the same procedure
- The tables are extended in both temperature and density to cover lower temperatures and higher densities.
- The previous standard used a significant digit format which resulted in 4 or 5 decimal places depending on whether the observed temperature was above or below the reference temperature. The new standard prescribes 5 decimal places if or both cases.
- The IP paper No. 3 tables were added to accommodate conversion to 20°C.

Tables for lubricating oils including the implementation procedures are now part of the standard.

In **2007** an addendum to API 11.1:2004 has been released.

NGL and LPG tables

For NGL and LPG products volume correction tables 24E and 23E (at 60 °F) were published in **GPA TP-25** (1988), so the letter 'E' was used to distinguish the tables from the related API MPMS A, B, C and D tables.

GPA TP-25 has been superseded by **GPA TP-27** / API MPMS 11.2.4 (2007), which includes tables 53E, 54E, 59E and 60E to convert to 15°C and 20°C as well. All text from TP-25 is included without technical change, so TP-25 is still viable for conversion to and from 60 °F.

As opposed to API MPMS 11.1:1980 (API-2540), method 1 does not apply for API MPMS 11.1:2004/2007, because the latter standard assumes an equilibrium pressure of 0 psig.

Overview of hydrocarbon liquid conversion standards

- ASTM-IP Petroleum Measurement Tables, Historical Edition, 1952
- API MPMS Chapter 11.1□ - 1980* (Temperature VCFs for Generalized Crude Oils, Refined Products, and Lubricating Oils): Historical; Published in 14 separate volumes
Also known as:
 - API Standard 2540 (API-2540)
 - ASTM D1250
 - IP 200
- In 1982 chapters XIII and XIV were published containing tables 5D, 6D, 53D and 54D for lubricating oils.
- API MPMS Chapter 11.1□ - 2004 (Temperature & Pressure VCFs for Generalized Crude Oils, Refined Products and Lube Oils)
- API MPMS Chapter 11.1□ - 2004 (Temperature & Pressure VCFs for Generalized Crude Oils, Refined Products and Lube Oils) – Addendum 1, September 2007.
- API MPMS Chapter 11.2.1- 1984 (Compressibility Factors for Hydrocarbons: 0-90°API): Historical: now incorporated into Chapter 11.1-2004
- API MPMS Chapter 11.2.1M- 1984 (Compressibility Factors for Hydrocarbons: 638-1074 kg/m³): Historical: now incorporated into Chapter 11.1-2004
- API MPMS Chapter 11.2.2 - 1984 (Compressibility Factors for Hydrocarbons: 0.350-0.637 Relative Density and -50°C to 140°C)
- API MPMS Chapter 11.2.2M - 1986 (Compressibility Factors for Hydrocarbons: 350-637 kg/m³ Density (15°C) and -46°C to 60°C)
- API MPMS Chapter 11.2.2A - 1984 (Addendum to Correlation of Vapor Pressure Correction for NGL): Superseded by Chapter 11.2.5
- API Publication/GPA TP-25/ASTM Publication (Temperature Correction for the volume of Light Hydrocarbons – Tables 24E and 23E: Superseded by API MPMS Chapter 11.2.4
GPA TP-25 was published in 1998 and replaced the 1952 tables 23, 24 for Light Hydrocarbon Liquids and GPA Technical Publication TP-16, which were previously used for volumetric measurement of LPG.
- API MPMS Chapter 11.2.4 - 2007 / GPA TP-27 / ASTM Publication (Temperature Correction for the Volume of NGL and LPG – Tables 23E, 24E, 53E, 54E, 59E, 60E): Supersedes GPA TP-25
- API MPMS Chapter 11.2.5 - 2007 / GPA TP-15 / ASTM Publication (A Simplified Vapor Pressure Correlation for Commercial NGLs): Supersedes Addendum to Chapter 11.2.2 (11.2.2A)
- IP No. 3 - 1988 (Energy Institute (formerly Institute of Petroleum), Petroleum Measurement Paper No 3 Computer Implementation Procedures for Correcting Densities and Volumes to 20 C. Superseded by IP No.3 - 1997
- IP No. 3 - 1997 (Energy Institute (formerly Institute of Petroleum), Petroleum Measurement Paper No 3 Computer Implementation Procedures for Correcting Densities and Volumes to 20 C. Supersedes IP No.3 - 1988

- ISO 91-1 - 1982 Petroleum measurement tables Part 1: Tables based on reference temperatures of 15 °C and 60 °F. Superseded by ISO 91-1 1992.
- ISO 91-1 - 1992 Petroleum measurement tables Part 1: Tables based on reference temperatures of 15 °C and 60 °F. Supersedes ISO 91-1 1982.
- ISO 91-2 - 1991 Petroleum measurement tables Part 2: Tables based on reference temperatures of 20 °C
- OIML R 63 - 1994 Petroleum measurement tables

Overview of the functions

The following table lists the volume conversion functions for hydrocarbon liquids as provided by the Liquid Metric application

Function	Temperature correction	Pressure correction	Input	Output
Crude Oils, Refined Products and Lubricating Oils (API 1952)				
API_Table5 (1952)	API 1952 Table 5	API 11.2.1:1984	RD (T,P)	RD (60°F, Pe)
API_Table6 (1952)	API 1952 Table 6	API 11.2.1:1984	RD(60°F, Pe)	RD (T, P)
API_Table23 (1952)	API 1952 Table 23	API 11.2.1:1984	RD (T, P)	RD (60°F, Pe)
API_Table24 (1952)	API 1952 Table 24	API 11.2.1:1984	RD (60°F, Pe)	RD (T, P)
API_Table53 (1952)	API 1952 Table 53	API 11.2.1M:1984	Density (T, P)	Density (15°C, Pe)
API_Table54 (1952)	API 1952 Table 54	API 11.2.1M:1984	Density (15°C, Pe)	Density (T, P)
Crude Oils, Refined Products and Lubricating Oils (API MPMS 11.1:1980 / API-2540)				
API_Table5 (1980)	API 11.1:1980 Tables 5A, 5B and 5D	API 11.2.1:1984	°API (T, P)	°API (60°F, Pe)
API_Table6 (1980)	API 11.1:1980 Tables 6A, 6B and 6D	API 11.2.1:1984	°API (60°F, Pe)	°API (T, P)
API_Table23 (1980)	API 11.1:1980 Tables 23A and 23B	API 11.2.1:1984	RD (T, P)	RD (60°F, Pe)
API_Table24 (1980)	API 11.1:1980 Tables 24A and 24B	API 11.2.1:1984	RD (60°F, Pe)	RD (T, P)
API_Table53 (1980)	API 11.1:1980 Tables 53A, 53B and 53D	API 11.2.1M:1984	Density (T, P)	Density (15°C, Pe)
API_Table54 (1980)	API 11.1:1980 Tables 54A, 54B and 54D	API 11.2.1M:1984	Density (15°C, Pe)	Density (T, P)
Crude Oils, Refined Products and Lubricating Oils (API MPMS 11.1:2004, addendum 1, 2007)				
API_Table5 (2007)	API 11.1:2007	API 11.1:2007	°API (T, P)	°API (60°F, 0 psig)
API_Table6 (2007)	API 11.1:2007	API 11.1:2007	°API (60°F, 0 psig)	°API (T, P)
API_Table23 (2007)	API 11.1:2007	API 11.1:2007	RD (T, P)	RD (60°F, 0 psig)
API_Table24 (2007)	API 11.1:2007	API 11.1:2007	RD (60°F, 0 psig)	RD (T, P)
API_Table53 (2007)	API 11.1:2007	API 11.1:2007	Density (T, P)	Density (15°C, 0 barg)
API_Table54 (2007)	API 11.1:2007	API 11.1:2007	Density (15°C, 0 barg)	Density (T, P)
API_Table59 (2007)	API 11.1:2007	API 11.1:2007	Density (T, P)	Density (20°C, 0 barg)
API_Table60 (2007)	API 11.1:2007	API 11.1:2007	Density (20°C, 0 barg)	Density (T, P)
NGL and LPG (API 11.2.4)				
API_Table23E	API 11.2.4: 2007 Table 23E	API 11.2.2:1986 GPA TP-15:1988 GPA TP-15:2007	RD (T, P)	RD (60°F, Pe)
API_Table24E	API 11.2.4: 2007 Table 24E	API 11.2.2:1986 GPA TP-15	RD (60°F, Pe)	RD (T, P)
API_Table53E	API 11.2.4: 2007 Table 53E	API 11.2.2:1986 GPA TP-15	Density (T, P)	Density (15°C, Pe)
API_Table54E	API 11.2.4: 2007 Table 54E	API 11.2.2:1986 GPA TP-15	Density (15°C, Pe)	Density (T, P)
API_Table59E	API 11.2.4: 2007 Table 59E	API 11.2.2M:1986 GPA TP-15	Density (T, P)	Density (20°C, Pe)
API_Table60E	API 11.2.4: 2007 Table 60E	API 11.2.2M:1986 GPA TP-15	Density (20°C, Pe)	Density (T, P)

Hydrometer Correction

The API MPMS 11.1 1980 Standard (API-2540) assumes that the API gravity or relative density is observed with a glass hydrometer. Therefore a correction may be applied for the change of volume of the glass hydrometer with temperature.

The 2004/2007 standard does not include a correction for a glass hydrometer.

API-2540 Input Data Limits

API MPMS 11.1:1980 (API 2540) is based on published data that lie within the so-called 'Data' range. The other table values were obtained from extrapolation and lie within the 'Extrapolated' range. It is recommended not to use API-2540 outside the 'Data' and 'Extrapolated' ranges.

For the lubricating oil tables no difference is made between data that is table values that are based on published data and table values that are determined by extrapolation.

Range	API Gravity [°API]	Relative Density [-]	Density [kg/m ³]	Temperature [°F]	Temperature [°C]
Data Range	0 .. 40	1.0760 .. 0.8250	1075.0 .. 824.0	0 .. 250	-18..120
	40 .. 50	0.8250 .. 0.7795	824.0 .. 778.5	0 .. 200	-18..90
	50 .. 55	0.7795 .. 0.7585	778.5 .. 758.0	0 .. 150	-18..60

Range	API Gravity [°API]	Relative Density [-]	Density [kg/m ³]	Temperature [°F]	Temperature [°C]
Extrapolated Range	0 .. 40	1.0760 .. 0.8250	1075.0 .. 824.0	250 .. 300	120..150
	40 .. 50	0.8250 .. 0.7795	824.0 .. 778.5	200 .. 250	90..125
	50 .. 55	0.7795 .. 0.7585	778.5 .. 758.0	150 .. 200	60..95
	55 .. 100	0.7585 .. 0.6110	758.0 .. 610.5	0 .. 200	-18..95
Applies for:	Table 5A	Table 23A	Table 53A	Table 5A	Table 53A
	Table 6A	Table 24A	Table 54A	Table 6A	Table 54A
				Table 23A	
				Table 24A	

Table 3: Table A input data limits for API MPMS 11.1:1980 (API 2540)

Range	API Gravity [°API]	Relative Density [-]	Density [kg/m ³]	Temperature [°F]	Temperature [°C]
Data Range	0 .. 40	1.0760 .. 0.8250	1075.0 .. 824.0	0 .. 250	-18..120
	40 .. 50	0.8250 .. 0.7795	824.0 .. 778.5	0 .. 200	-18..90
	50 .. 85	0.7795 .. 0.6535	778.5 .. 653.0	0 .. 150	-18..60
Extrapolated Range	0 .. 40	1.0760 .. 0.8250	1075.0 .. 824.0	250 .. 300	120..150
	40 .. 50	0.8250 .. 0.7795	824.0 .. 778.5	200 .. 250	90..125
	50 .. 85	0.7795 .. 0.6535	778.5 .. 653.0	150 .. 200	60..95
Applies for:	Table 5B	Table 23B	Table 53B	Table 5B	Table 53B
	Table 6B	Table 24B	Table 54B	Table 6B	Table 54B
				Table 23B	
				Table 24B	

Table 4: Table B input data limits for API MPMS 11.1:1980 (API 2540)

Range	API Gravity [°API]	Relative Density [-]	Density [kg/m ³]	Temperature [°F]	Temperature [°C]
Data Range	-10..45	0.8..1.165	800..1164	0 .. 300	-20..+150
Applies for:	Table 5D	Table 23D*	Table 53D	Table 5D	Table 53D
	Table 6D	Table 24D*	Table 54D	Table 6D	Table 54D
				Table 23D*	
				Table 24D*	

* Values derived from Table 5D/6D

Table 5: Table D input data limits for API MPMS 11.1:1982

API-2540 Rounding and truncating rules

For each table API Standard 2540 specifies an explicit 'Calculation Procedure' that includes the rounding and truncating of all the input, intermediate and output values. The 'Calculation Procedure' is considered to be the standard rather than the table values or a set of equations.

The function provides the option to either apply the full API rounding and truncating requirements or to perform the calculation procedure without any rounding and truncating being applied.

For tables 6A, 6B, 24A, 24B and 54A and 54B the standard makes a distinction between computational and table values for the calculated VCF. The table values are always rounded to 4 decimal places, Whereas the computational values has 4 decimal places when the VFC >=1 and 5 decimal places when the VCF < 1.

When API rounding is enabled the convergence limit is set to the limit value as specified in the standard. When the API rounding is disabled the convergence limit is set to 0.00001 kg/m³ to obtain highest precision.

API-11.1:2004/2007 Input Data Limits

Range	Density	Temperature	Pressure
Crude Oil	610.6..1163.5 kg/m ³ @ 60°F 100..-10 API @ 60°F 0.61120..1.16464 RD @ 60°F 611.16..1163.79 kg/m ³ @ 15°C 606.12..1161.15 kg/m ³ @ 20°C	-58..302 °F -50..150 °C	0..1500 psig 0..103.4 bar(g)
Refined products	610.6..1163.5 kg/m ³ @ 60°F 100..-10 API @ 60°F 0.61120..1.16464 RD @ 60°F 611.16..1163.86 kg/m ³ @ 15°C 606.12..1160.62 kg/m ³ @ 20°C	-58..302 °F -50..150 °C	0..1500 psig 0..103.4 bar(g)
Lubricating oils	800.9..1163.5 kg/m ³ @ 60°F 45..-10 API @ 60°F 0.80168..1.1646 RD @ 60°F 801.25..1163.85 kg/m ³ @ 15°C 798.11..1160.71 kg/m ³ @ 20°C	-58..302 °F -50..150 °C	0..1500 psig 0..103.4 bar(g)

Table 6: API-11.1: 2004/2007 input data limits

API constants

For the tables in [metric units](#) the following constants apply (both for the 1980 and the 2004/2007 tables):

Product	API Table	K0	K1	K2
Crude oil	A	613.9723	0.0	0.0
Gasoline	B	346.4228	0.4388	0.0
Transition area	B	2680.3206	0.0	-0.00336312
Jet fuels	B	594.5418	0.0	0.0
Fuel oils	B	186.9696	0.4862	0.0
Lubricating oils	D	0.0	0.6278	0.0

Table 7: API-11.1 constants (metric units)

For the tables in [US customary units](#) the following constants apply (both for the 1980 and the 2004/2007 tables):

Product	API Table	K0	K1	K2
Crude oil	A	341.0957	0.0	0.0
Gasoline	B	192.4571	0.2438	0.0
Transition area	B	1489.0670	0.0	-0.00186840
Jet fuels	B	330.3010	0.0	0.0
Fuel oils	B	103.8720	0.2701	0.0
Lubricating oils	D	0.0	0.34878	0.0

Table 8: API-11.1 constants (US customary units)

Volume Correction factor C_{TL}

The volume correction factor for temperature C_{tl} is determined based on the selected **Density conversion method** (refer to display: Configuration, Products).

$$C_{TL} = e^{(-\alpha_T \times \Delta T \times [1 + (0.8 \times \alpha_T \times \Delta T)])}$$

Equation 6-17: Volume Correction Factor C_{TL}

$$\alpha_T = \frac{K_0 + K_1 \times \rho_{STD} + K_2 \times \rho_{STD}^2}{\rho_{STD}^2}$$

Equation 6-17: Tangent thermal expansion coefficient α_T

C _{TL}	Volume Correction Factor	[-]
α _T	Tangent thermal expansion coefficient per °C at reference temperature	
ΔT	Reference temperature – meter (flowing) temperature	[°C]
ρ _{STD}	Standard density	[kg/m ³]

Volume Correction factor C_{PL}

The correction for pressure was published in API MPMS standards 11.2.1 and 11.2.2. The correction for pressure is to the atmospheric pressure or, for products within the lower density range, to the equilibrium vapor pressure.

To calculate the equilibrium vapor pressure for NGL/LPG an Addendum was added to API MPMS 11.2.2. This addendum is also known as **GPA TP-15** (1988). In September 2007 the addendum was replaced by a new API standard 11.2.5 and at the same time GPA TP-15 (1988) was updated with a new 2007 revision.

$$C_{PL} = \frac{1}{1 - (P - P_e) \times F}$$

Equation 6-18: Volume Correction Factor C_{PL}

C _{PL}	Volume correction factor for pressure	-
P	Line Pressure	bar(g)
P _e	Equilibrium Vapor Pressure (EVP)	
F	Compressibility Factor as calculated with the selected API standard	-

Density calculations

The density value depends on the type of fluid and the temperature and pressure conditions. The following fluid density related properties are distinguished within the application:

- Observed density
Density at the corresponding density input conditions
- Meter density
Density at the flow meter conditions
- Standard density
Density at the reference conditions

The actual calculations that are used to calculate these properties depend on the way that the observed and standard density are determined, which is controlled through configuration settings **Observed density input type** and **Standard density input type** on display Configuration, Run <x>, Run setup or, in case of product definition on station level, Configuration, Station, Station setup.

The standard density is either calculated from the observed density based on the selected density conversion method or is a direct input value that is set manually through the operator interface or remotely via a communications link.

The meter density (or flowing density) is the density at the temperature and pressure conditions at the flow meter and is calculated from the standard density, and the C_{tl} and C_{pl} factors.

$$\rho_f = \rho_s \times C_{TL} \times C_{PL}$$

Equation 6-7: Meter density calculation

ρ _f	Meter density (flowing density)	[kg/m ³]
ρ _s	Standard density	[kg/sm ³]
C _{TL}	Ctl factor	[-]
C _{PL}	Cpl factor	[-]

The relationship between relative density and density is as follows:

$$RD = \frac{\rho}{\rho_{H2O}}$$

Equation 6-1: Relative density calculation

RD	Relative density / specific gravity	[-]
ρ	Density	[kg/m ³]
ρ _{H2O}	Density of water at reference temperature	[kg/m ³]

The relationship between the API gravity and the relative density is as follows:

$$API = \frac{141.5}{RD + 131.5}$$

Equation 6-2: API gravity calculation

API	API gravity	[°API]
RD	Relative density / specific gravity	[-]

Densitometer calculations

The flow computer supports the following type of densitometers:

- Solartron
- Sarasota
- UGC
- Anton Paar

Solartron densitometers

The flow computer provides the option to calculate the density from a frequency input signal provided by a Solartron 7810, 7811 or 7812 gas densitometer and to correct it for temperature and velocity of sound effects

The calculations are in accordance with the following vendor documentation:

- 78125010 'Solartron 7812 Gas Density Transducer Manual', 2001.
- 78125040 Rev. C, 'Micro Motion 7812 Gas Density Meter', October 2007.

$$\rho_i = K_0 + K_1 \cdot \tau + K_2 \cdot \tau^2$$

Equation 6-3: Uncorrected density (Solartron)

ρ_i	Uncorrected density	kg/m3
K_0	Obtained from the calibration certificate	-
K_1	Obtained from the calibration certificate	-
K_2	Obtained from the calibration certificate	-
τ	Time period from densitometer	μ s

$$\rho_t = \rho_i \cdot [1 + K_{18} \times (T - T_R)] + K_{19} \times (T - T_R)$$

Equation 6-4: Density corrected for temperature (Solartron)

ρ_t	Density corrected for temperature	kg/m3
K_{18}	Obtained from the calibration certificate	-
K_{19}	Obtained from the calibration certificate	-
T	Density temperature	°C
T_R	Densitometer reference temperature	°C

$$\rho_{pt} = \rho_t \times [1 + (K_{20} \times P_f)] + (K_{21} \times P_f)$$

$$K_{20} = K_{20A} + (K_{20B} \times P_f)$$

$$K_{21} = K_{21A} + (K_{21B} \times P_f)$$

Equation 6-5: Density corrected for Pressure (Solartron)

ρ_{pt}	Density corrected for pressure and temperature	kg/m3
ρ_t	Density corrected for temperature	kg/m3
K_{18}	Obtained from the calibration certificate	-
K_{19}	Obtained from the calibration certificate	-
K_{20A}	Obtained from the calibration certificate	-
K_{20B}	Obtained from the calibration certificate	-
K_{21A}	Obtained from the calibration certificate	-
K_{21B}	Obtained from the calibration certificate	-
P_f	Density pressure	bar(g)

$$\rho_{VOS} = \rho_{pt} + K_r \times (\rho_{pt} - K_j)^3$$

Equation 6-6: Density corrected for Velocity of Sound effects (Solartron)

ρ_{pt}	Density corrected for pressure and temperature	kg/m3
K_r	Obtained from the calibration certificate	-
K_j	Obtained from the calibration certificate	-

Sarasota densitometers

$$\rho_C = d_0 \cdot \frac{\tau - \tau_C}{\tau_C} \cdot \left(2 + K \cdot \frac{\tau - \tau_C}{\tau_C} \right)$$

$$\tau_C = \tau_0 + T_{COEF} \cdot (T - T_R) + P_{COEF} \cdot (P - P_R)$$

Equation 6-7: Corrected density (Sarasota)

ρ_C	Corrected density	kg/m3
d_0	Obtained from the calibration certificate	kg/m3
τ_0	Obtained from the calibration certificate	μ s
K	Obtained from the calibration certificate	-
d_0	Obtained from the calibration certificate	-
P_{COEF}	Obtained from the calibration certificate	μ s/bar
T_{COEF}	Obtained from the calibration certificate	μ s/°C
T	Density temperature	°C
T_R	Densitometer reference temperature	°C
P	Density pressure	bar(g)
P_R	Densitometer reference pressure	bar(g)
τ_C	Time periodic input corrected for temperature and pressure	μ s
τ	Time period from densitometer	μ s

UGC densitometers

$$\rho_i = K_0 + K_1 \cdot \tau + K_2 \cdot \tau^2$$

Equation 6-8: Uncorrected density (UGC)

ρ_i	Uncorrected density	kg/m3
K_0	Obtained from the calibration certificate	-
K_1	Obtained from the calibration certificate	-
K_2	Obtained from the calibration certificate	-
τ	Time period from densitometer	μ s

$$\rho_t = \rho_i + [K_{p1} + K_{p2} \cdot \rho_i + K_{p3} \cdot \rho_i^2] \cdot (P - P_R) + [K_{T1} + K_{T2} \cdot \rho_i + K_{T3} \cdot \rho_i^2] \cdot (T - T_R)$$

Equation 6-9: Corrected density (UGC)

ρ_t	Density corrected for temperature and pressure	kg/m3
K_{p1}	Obtained from the calibration certificate	-
K_{p2}	Obtained from the calibration certificate	-
K_{p3}	Obtained from the calibration certificate	-
K_{T1}	Obtained from the calibration certificate	-
K_{T2}	Obtained from the calibration certificate	-
K_{T3}	Obtained from the calibration certificate	-
T	Density temperature	°C
T_R	Densitometer reference temperature	°C
P	Density pressure	bar(g)
P_R	Densitometer reference pressure	bar(g)

Anton Paar densitometers

For conventional Anton Paar densitometers the following equations are used to calculate the observed density from the frequency signal:

$$\rho_t = DA \cdot \tau^2 \cdot (1 + DA_1 \cdot T + DA_2 \cdot T^2) - DB \cdot (1 - DA_3 \cdot T)$$

Equation 6-10: Density corrected for temperature (Anton Paar)

ρ_t	Density corrected for temperature	kg/m3
DA	Obtained from the calibration certificate	-
DA ₁	Obtained from the calibration certificate	-
DA ₂	Obtained from the calibration certificate	-
DA ₃	Obtained from the calibration certificate	-
DB	Obtained from the calibration certificate	-
τ	Time period from densitometer	μ s
T	Density temperature	$^{\circ}$ C

$$LCF = a_0 + a_1 * \log(x) + a_2 * \log(x)^2 + a_3 * \log(x)^3 + a_4 * \log(x)^4 + a_5 * \log(x)^5 + a_6 * \log(x)^6$$

$$\rho_{tp} = \rho_t + DP_0 + DP_1 \cdot (P - P_R) + DP_2 \cdot (P - P_R)^2 + DP_3 \cdot \rho_t \cdot (P - P_R)$$

Equation 6-11: Density corrected for temperature and pressure (Anton Paar)

ρ_{tp}	Density corrected for temperature and pressure	kg/m3
ρ_t	Density corrected for temperature	kg/m3
DP ₀	Obtained from the calibration certificate	-
DP ₁	Obtained from the calibration certificate	-
DP ₂	Obtained from the calibration certificate	-
DP ₃	Obtained from the calibration certificate	-
P	Density pressure	bar(g)
P _R	Densitometer reference pressure	bar(g)

Usually the **reference pressure** for Anton Paar densitometers is 1 bar(a), which equals -0.01325 bar(g) if the **atmospheric pressure** is set to 1.01325 bar(a).

Meter body correction

For ultrasonic flow meters a correction may be applied to compensate for the effect of the meter body expansion as a function of temperature and pressure of the fluid.

$$MBF = 1 + \epsilon_T \times (T - T_R) + \epsilon_P (P - P_R)$$

Equation 6-12: Meter body correction factor

MBF	Meter body correction factor	[-]
ϵ_T	Cubical temperature expansion coefficient	[m3/m3/ $^{\circ}$ C]
T	Fluid temperature at the flow meter	[$^{\circ}$ C]
T _R	Reference temperature for the expansion	[$^{\circ}$ C]
ϵ_P	Cubical pressure expansion coefficient	[m3/m3/bar]
P	Fluid pressure at the flow meter	[bar(a)]
P _R	Reference pressure for the expansion	[bar(a)]

Cubical expansion coefficient = Linear expansion coefficient x 3.

Viscosity correction

If enabled a correction for product viscosity is applied on the volume flow rate indicated by the flow meter.

A different correction is applied for a (helical) turbine, a positive displacement flow meter and ISO 4124:1996

Turbine flow meter:

$$LCF = A + \frac{B}{x} + \frac{C}{x^2} + \frac{D}{x^3} + \frac{E}{x^4} + \frac{F}{x^5} + \frac{G}{x^6}$$

Equation 6-13: Viscosity correction factor for turbine flow meters

Positive displacement flow meter:

$$LCF = A + \frac{x^C}{B}$$

Equation 6-14: Viscosity correction factor for positive displacement flow meters

ISO 4124:1994

$$LCF = a_0 + a_1 * \log(x) + a_2 * \log(x)^2 + a_3 * \log(x)^3 + a_4 * \log(x)^4 + a_5 * \log(x)^5 + a_6 * \log(x)^6$$

Equation 6-15: Viscosity correction factor for positive displacement flow meters

LCF	Viscosity correction factor	[-]
x	Qi / Vis	
Qi	Indicated volume flow rate	[m3/hr]
Vis	In-use product viscosity	[cSt]
A..F	Correction constants, usually provided by the flow meter manufacturer	
a0-a6	Correction constants for ISO 4124:1996	

Correction for Sediment and Water (BS&W)

$$C_{BSW} = 1 - \frac{BSW}{100}$$

Equation 6-16: Volume Correction Factor C_{S&W}

C _{BSW}	Correction factor for the percentage of sediment and water content in the fluid.	[-]
BSW	Percentage of sediment and water content in the fluid.	[%]

Flow rates for volumetric flow meters

The following equations apply for any flow meter that provides a volumetric quantity as a pulse input signal or as a smart signal (communications, HART or analog input)

It typically applies for the following type of meters:

- Turbine flow meter
- Positive displacement (PD) flow meter
- Ultrasonic flow meter providing a pulse signal

Indicated flow rate

For a flow meter that provides a pulse signal the meter K-factor is applied to obtain the indicated flow rate from the pulse frequency.

$$Q_{IV} = \frac{f}{MKF} \times 3600$$

Equation 6-17: Indicated volume flow rate (volumetric flow meters)

Q_{IV}	Indicated (volume) flow rate	[m ³ /hr]
MKF	Meter K-factor	[pulses/m ³]
f	Pulse frequency	[Hz]

For smart flow meters the indicated volume flow rate is obtained directly from the flow meter.

Gross volume flow rate

The gross volume flow rate (corrected flow rate) is derived from the indicated flow rate (uncorrected flow rate) using this formula:

$$Q_{GV} = Q_{IV} \times MF \times MBF \times LCF$$

Equation 6-18: Gross volume flow rate (volumetric flow meters)

Q_{GV}	Gross volume flow rate	[m ³ /hr]
Q_{IV}	Indicated volume flow rate	[m ³ /hr]
MF	Meter factor	[-]
MBF	Meter body correction factor	[-]
LCF	Viscosity correction factor	[-]

The meter factor is calculated from the meter error by this formula:

$$MF = \frac{100}{100 + ME}$$

Equation 6-19: Meter factor from Meter error

ME	Meter error	[%]
----	-------------	-----

Mass flow rate

$$Q_M = \frac{Q_{GV} \times \rho_f}{1000}$$

Equation 6-20: Mass flow rate (volumetric flow meters)

Q_M	Mass flow rate	[tonne/hr]
Q_{GV}	Gross volume flow rate	[m ³ /hr]
ρ_f	Fluid density at the meter conditions	[kg/sm ³]

Flow rates for mass flow meters

The following equations apply for any flow meter that provides a mass quantity as a pulse input signal or as a smart signal (communications, HART or analog input). It typically applies for Coriolis flow meters.

Indicated flow rate

If the flow meter provides a pulse signal, then the meter K-factor is applied to obtain the indicated mass flow rate from the pulse frequency.

$$Q_{IM} = \frac{f}{MKF} \times 3600$$

Equation 6-21: Indicated mass flow rate (mass flow meters)

Q_{IM}	Indicated (mass) flow rate	[tonne/hr]
MKF	Meter K-factor	[pulses/tonne]
f	Pulse frequency	[Hz]

For smart flow meters the indicated mass flow rate is obtained directly from the flow meter.

Mass flow rate

The mass flow rate (corrected flow rate) is derived from the indicated mass flow rate (uncorrected flow rate) using this formula:

$$Q_M = Q_{IM} \times MF \times MBF \times LCF$$

Equation 6-22: Mass flow rate (mass flow meters with pulse signal)

Q_M	Mass flow rate	[tonne/hr]
Q_{IM}	Indicated (mass) flow rate	[tonne/hr]
MF	Meter factor	[-]
MBF	Meter body correction factor	[-]
LCF	Viscosity correction factor	[-]

The meter factor is calculated from the meter error by this formula:

$$MF = \frac{100}{100 + ME}$$

Equation 6-23: Meter factor from Meter error

ME	Meter error	[%]
----	-------------	-----

Gross volume flow rate

$$Q_{GV} = \frac{Q_M * 1000}{\rho_f}$$

Equation 6-24: Gross volume flow rate for water / steam and ethylene (volumetric flow meters)

Q_{GV}	Gross volume flow rate	[m ³ /hr]
Q_M	Mass flow rate	[tonne/hr]
ρ_f	Fluid density at the flow meter conditions	[kg/m ³]

Standard volume flow rate

Gross standard volume flow rate

$$Q_{GSV} = Q_{GV} \times \frac{\rho_f}{\rho_s}$$

Equation 6-25: Gross standard volume flow rate

Q_{GSV}	Gross standard volume flow rate	[sm ³ /hr]
Q_{GV}	Gross volume flow rate	[m ³ /hr]
ρ_f	Fluid density at the flow meter conditions	[kg/m ³]
ρ_s	Fluid density at standard conditions	[kg/sm ³]

Net standard volume flow rate

$$Q_{NSV} = Q_{GSV} \times C_{BSW}$$

Equation 6-26: Net standard volume flow rate

Q_{NSV}	Net standard volume flow rate	[sm ³ /hr]
Q_{GSV}	Gross standard volume flow rate	[sm ³ /hr]
C_{BSW}	Correction factor for the percentage of sediment and water content in the fluid.	[-]

Flow rate for differential pressure flow devices

The method uses the equations from the International Standard ISO 5167-1: 'Measurement of Fluid Flow by means of pressure differential devices, Part 1: Orifice plates, nozzles and venturi tubes inserted in circular cross-section conduits running full'.

Mass flowrate (ISO-5167)

$$q_M = \frac{C}{\sqrt{1-\beta^4}} \times \varepsilon \times \frac{\pi}{4} d^2 \times \sqrt{2 \times \Delta P \times \rho_1}$$

Equation 6-27: ISO-5167 mass flow rate

q_M	Mass flowrate	kg/sec
C	Coefficient of Discharge	-
ε	Fluid expansion factor	-
π	3.14159	
d	Orifice diameter at line temperature	m
ρ_1	Flowing density at line conditions	kg/m ³
ΔP	Differential pressure	Pa

$$Q_M = \frac{q_M * 3600}{1000}$$

Equation 6-28: Mass flow rate in practical working units (orifice plate)

Device and pipe diameter (Corrected) at operating temperature

$$d = d_r [1 + \alpha_1 (T_L - T_R)]$$

Equation 6-29: Orifice Diameter correction

$$D = D_r [1 + \alpha_1 (T_L - T_R)]$$

Equation 6-30: Pipe Diameter correction

d	Orifice diameter at operating temperature	mm
d_r	Orifice diameter at reference temperature	mm
D	Pipe diameter at operating temperature	mm
D_r	Pipe diameter at reference temperature	mm
α_1	Coefficient of expansion of orifice and pipe material	mm/mm/°C
T_L	Fluid temperature at operating conditions	°C
T_R	Reference temperature of the Orifice/Pipe.	°C

Diameter (Beta) Ratio

$$\beta = \frac{d}{D}$$

Equation 6-31: Beta ratio calculation

Reynolds Number

$$R_D = \frac{4 \times q_m}{\pi \times \mu \times D}$$

Equation 6-32: Reynolds Number based on Pipe diameter

R_D	Reynolds Number	-
q_m	Mass flowrate	kg/sec
π	3.14159	-
μ	Fluid dynamic viscosity	Pa-sec
D	Pipe diameter	m

Velocity of Approach (E_v)

$$E_v = \frac{1}{\sqrt{1-\beta^4}}$$

Equation 6-33: ISO-5167 Velocity of Approach calculation

Fluid Expansion Factor ε

ⓘ The ISO-5167 equation for the Fluid Expansion factor only applies for compressible fluids (gasses). For incompressible fluids (liquids) the Fluid Expansion factor is set to 1.

AGA-5167 defines the following equation for the Fluid Expansion Factor for orifices:

$$\varepsilon = 1 - (0.41 + 0.35 \times \beta^4) \times \frac{X_1}{\kappa}$$

Equation 6-34: ISO-5167 Reynolds Expansion Factor (Gas)

ε	Expansion Factor	-
β	Beta ratio	-
X_1	Ratio of differential pressure to absolute static pressure at the upstream tap	
κ	Isentropic exponent	-

Down- to upstream corrections

The calculation of the mass flow rate from a differential pressure flow device (orifice, venturi, V-cone or nozzle) requires the temperature, pressure and density values upstream of the flow device. For a variable that is measured downstream of the flow meter, a downstream to upstream correction is required.

Two downstream measurement locations are supported, namely at the downstream tap and at the location where the pressure has fully recovered from the pressure drop over the flow device.

Pressure correction

In most cases the static pressure is taken from the upstream tap, so no correction is required. When the pressure is measured downstream of the flow device then the following corrections are taken.

- The relation between the pressure at the upstream tapping p_1 and the pressure at the downstream tapping (p_2) is as follows:

$$P_1 = P_2 + \Delta P / 1000$$

- The relation between the pressure at the upstream tapping and the fully recovered downstream tapping is as follows:

$$P_1 = P_3 + P_{LOSS}$$

The calculation of P_{LOSS} is as defined in the ISO-5167 standard.

P_1	Pressure at upstream tapping	[bar(a)]
P_2	Pressure at downstream tapping	[bar(a)]
P_3	Fully recovered downstream pressure	[bar(a)]
ΔP	Differential pressure	[mbar]
P_{LOSS}	Pressure loss over the meter	[bar]

Temperature correction

Temperature correction is only valid for gaseous fluids (steam). For liquid fluids, temperature correction is disabled.

The method used to correct the temperature from downstream to upstream conditions is user-definable. The following 3 methods are provided:

- Method 1: Isentropic expansion based on the isentropic coefficient κ .

$$T_1 = (T_2 + 273.15) \times \left(\frac{P_2}{P_1} \right)^{\frac{1-\kappa}{\kappa}} - 273.15$$

$$T_1 = (T_3 + 273.15) \times \left(\frac{P_3}{P_1} \right)^{\frac{1-\kappa}{\kappa}} - 273.15$$

- Method 2: Isentropic expansion based on the separate user-definable parameter 'Temperature exponent' K_{TE} :

$$T_1 = (T_2 + 273.15) \times \left(\frac{P_2}{P_1} \right)^{K_{TE}} - 273.15$$

$$T_1 = (T_3 + 273.15) \times \left(\frac{P_3}{P_1} \right)^{K_{TE}} - 273.15$$

- Method 3: Jenthalpic expansion based on the linear Joule Thomson correction as defined in ISO5167-1:2003, taking parameter 'Temperature exponent' as the Joule Thomson coefficient μ_{JT} :

$$T_1 = T_2 + (P_1 - P_2) \cdot \mu_{JT}$$

$$T_1 = T_3 + (P_1 - P_3) \cdot \mu_{JT}$$

T_1	Upstream temperature	°C
T_2	Downstream temperature	°C
T_3	Temperature at recovered pressure position	°C
P_1	Upstream pressure	bar(a)
P_2	Downstream pressure	bar(a)
P_3	Fully recovered downstream pressure	bar(a)
κ	Iisentropic exponent	-
K_{TE}	Temperature exponent	-
μ_{JT}	Joule Thomson coefficient	°C/bar

Orifice correction for drain hole

Only applicable for gaseous products like steam.

A drain hole may have been drilled into the bottom of the orifice plate to prevent condensate from interfering with measurement. The option is provided to define a drain hole diameter. When the drain hole diameter is larger than 0 then the following correction factor is applied on the orifice diameter according to the British standard 1042: Part 1: 1964.

$$C_{DH} = 1 + 0.55 * \left(\frac{d_{DH}}{d_0} \right)^2$$

C_{DH}	Drain hole correction factor on orifice diameter	[-]
d_{DH}	Drain hole diameter	[mm]
d_0	Orifice diameter at reference temperature	[mm]

Differential pressure cell selection

When more than 1 differential pressure measurement is applied on a differential pressure flow device, then one of the measurements will be used for the calculation of the mass flow rate. The flow computer provides several different selection methods meter runs using 2 or 3 differential pressure cells.

2 cells, range type = 'Lo Hi'

When cell A is currently selected

- Select cell B when cell A value is above or equal to the switch-up percentage of its range and cell B is healthy.
- Select cell B when cell A fails while cell B is healthy

When cell B is currently selected

- Select cell A when cell A value is below or equal to the switch-down percentage of its range and cell A is healthy
- Select cell A when cell B fails and cell A is healthy

2 cells, range type = 'Hi Hi'

When cell A is currently selected

- Select cell B when cell A value fails and cell B is healthy

When cell B is currently selected

- Select cell A when cell A is healthy and 'Auto switchback' is enabled
- Select cell A when cell B fails and cell A is healthy.

3 cells, range type = 'Lo Mid Hi'

When cell A is currently selected

- Select cell B when cell A value is above or equal to the switch-up percentage of its range and cell B is healthy.
- Select cell B when cell A fails while cell B is healthy
- Select cell C when cell A and cell B fail and cell C is healthy

When cell B is currently selected

- Select cell C when cell B value is above or equal to the switch-up percentage of its range and cell C is healthy
- Select cell A when cell A value is below or equal to the switch-down percentage of its range and cell A is healthy
- Select cell A when cell B fails while cell A is healthy
- Select cell C when cell B and cell A fail and cell C is healthy

When cell C is currently selected

- Select cell B when cell B value is below or equal to the switch-down percentage of its range and cell B is healthy
- Select cell B when cell C fails while cell B is healthy
- Select cell A when cell C and cell B fail and cell A is healthy

3 cells, range type = 'Lo Hi Hi'

When cell A is currently selected

- Select cell B when cell A value is above or equal to the switch-up percentage of its range and cell B is healthy.
- Select cell C when cell A value is above or equal to the switch-up percentage of its range and cell B fails and cell C is healthy.
- Select cell B when cell A fails while cell B is healthy
- Select cell C when cell A and cell B fail and cell C is healthy

When cell B is currently selected

- Select cell A when cell A value is below or equal to the switch-down percentage of its range and cell A is healthy
- Select cell C when cell B fails while cell C is healthy
- Select cell A when cell B and cell C fail and cell A is healthy

When cell C is currently selected

- Select cell A when cell A value is below or equal to the switch-down percentage of its range and cell A is healthy

- Select cell B when cell B is healthy and 'Auto switchback' is enabled
- Select cell A when cell C and cell B fail and cell A is healthy

3 cells, range type = 'Hi Hi Hi'

When cell A is currently selected

- Select cell B when cell A value fails and cell B is healthy
- Select cell C when cell A and cell B fail and cell C is healthy

When cell B is currently selected

- Select cell A when cell A is healthy and 'Auto switchback' is enabled
- Select cell A when cell B fails and cell A is healthy
- Select cell C when cell B and A fail and cell C is healthy

When cell C is currently selected

- Select cell A when cell A is healthy and 'Auto switchback' is enabled
- Select cell B when cell B is healthy and cell A fails and 'Auto switchback' is enabled
- Select cell A when cell C fails and cell A is healthy
- Select cell B when cell C and A fail and cell B is healthy

Proving Calculations

Proving of volumetric meters with pipe / compact / small volume prover

The proved meter factor is calculated as following:

$$MF_P = \frac{PV_B \times C_{TSP} \times C_{PSP} \times C_{TLP} \times C_{PLP}}{\frac{P_f}{MKF} \times C_{TLM} \times C_{PLM}}$$

Equation 6-35: Prover Meter Factor for proving of volume flow meters.

MF _P	Meter factor calculated from proving	-
PV _B	Prover Base Volume at reference conditions (e.g.15°C and 0 bar(g))	m3
MKF	Meter K-factor	pulses/m3
P _f	Pulse count (whole pulses or interpolated, depending on whether double chronometry is enabled or not)	pulses
C _{TSP}	Correction factor for the effects of Temperature on the Prover volume ('S' stand for Steel)	-
C _{PSP}	Correction factor for the effects of Pressure on the Prover volume ('S' stands for Steel)	-
C _{TLP}	Correction for the effects of Temperature on the Liquid at the Prover	-
C _{PLP}	Correction for the effects of Pressure on the Liquid at the Prover	-
C _{TLM}	Correction for the effects of Temperature on the Liquid at the Meter	-
C _{PLM}	Correction for the effects of Pressure on the Liquid at the Meter	-

The calculations of C_{TLM} and C_{PLM} is defined in sections 'Volume Correction factor C_{TL}' and 'Volume Correction factor C_{PL}'

The calculation of C_{TLP} and C_{PLP} is similar to that of C_{TLM} and C_{PLM} , except that the average prover pressure and temperature is used (instead of the meter pressure and temperature).

$$\text{Average prover pressure} = (\text{Prover inlet pressure} + \text{Prover outlet pressure}) / 2$$

$$\text{Average prover temperature} = (\text{Prover inlet temperature} + \text{Prover outlet temperature}) / 2$$

The calculation of C_{TSP} differs for pipe provers and compact / small volume provers.

$$C_{TSP} = 1 + (\bar{T} - \bar{T}_b) \times t_{coef}$$

Equation 6-36: C_{TSP} calculation for pipe provers

T	Average Prover Temperature	°C
T_b	Base Prover temperature	°C
t_{coef}	Cubical thermal expansion coefficient of the prover steel	mm ³ /mm ³ /°C

$$C_{TSP} = \left(1 + (\bar{T} - \bar{T}_b) \times t_{coef_p}\right) \times \left(1 + (\bar{T}_i - \bar{T}_b) \times t_{coef_i}\right)$$

Equation 6-37: C_{TSP} calculation for compact and small volume provers

T	Average prover temperature	°C
T_i	Average prover (Invar) switch rod temperature	°C
T_b	Prover base volume temperature	°C
t_{coefp}	Square (area) thermal expansion coefficient of expansion of the prover steel	mm ² /mm ² /°C
t_{coefi}	Linear thermal expansion coefficient of expansion of the switch rod	mm/mm/°C

The calculation of C_{PSP} is the same for all prover types.

$$C_{PSP} = 1 + \frac{(P - P_b) \times D}{E \times t}$$

Equation 6-38: C_{PSP} calculation

P	Average prover pressure	bar(g)
P_b	Prover Base Pressure	bar(g)
D	Prover Internal diameter	mm
E	Modulus of elasticity of prover	-
T	Prover wall thickness	mm

Inferred mass proving

In case of inferred mass proving (proving of a mass flow meter using a volumetric prover) the prover meter factor is calculated as follows:

$$MF_P = \frac{PV_B \times C_{TSP} \times C_{PSP} \times \rho_p / 1000}{P_f / MKF}$$

Equation 6-39: Prover Meter Factor for (inferred mass) proving of mass flow meters.

MF_P	Meter factor calculated from proving	-
--------	--------------------------------------	---

PV_b	Prover Base Volume at reference conditions (e.g.15°C and 0 bar(g))	m3
MKF	Meter K-factor	pulses/tonne
P_f	Pulse count (whole pulses or interpolated, depending on whether double chronometry is enabled or not)	pulses
C_{TSP}	Correction factor for the effects of Temperature on the Prover volume ('S' stand for Steel)	-
C_{PSP}	Correction factor for the effects of Pressure on the Prover volume ('S' stands for Steel)	-
ρ_p	Prover density (measured with prover densitometer or calculated)	kg/m3

Master meter proving

Master meter proving is based on simultaneously measuring an amount of fluid by two meters that are installed in series. There are two different methods to calculate the volumes, by pulse counting or by totalizers latching.

Pulse counting

This method is only available if the flow computer reads pulses from both the meter on prove and the master meter.

The meter on prove and master meter prove totals (volume or mass totals, depending on meter quantity type) are calculated as follows:

$$Tot_{MM} = \frac{P_{MM}}{MKF_{MM}}$$

$$Tot_M = \frac{P_M}{MKF_M}$$

Equation 6-40: Master meter proving total measurement using the pulse counting method.

Tot_{MM}	Master meter prove total	m3 or tonne
P_{MM}	Pulses between start and stop of the prove counted by the master meter	-
MKF_{MM}	Actual K factor of the master meter (at the master meter frequency)	pls/m3 or pls/tonne
Tot_M	Meter on prove prove total	m3 or tonne
P_M	Pulses between start and stop of the prove counted by the meter on prove	-
MKF_M	Actual K factor of the meter on prove (at the meter frequency)	pls/m3 or pls/tonne

Totalizer latching

This method is also available for smart meters and / or master meters from which the flow computer doesn't read pulses.

The meter on prove and master meter prove totals (volume or mass totals, depending on meter quantity type) are calculated as follows:

$$Tot_{MM} = Tot_{MM}(stop) - Tot_{MM}(start)$$

$$Tot_M = (Tot_M(stop) - Tot_M(start)) \times \frac{t_{MM}}{t_M}$$

Equation 6-41: Master meter proving total measurement using the totalizer latching method.

Tot _{MM}	Master meter prove total	m3 or tonne
Tot _{MM} (stop)	Indicated totalizer of the master meter at prove end	m3 or tonne
Tot _{MM} (start)	Indicated totalizer of the master meter at prove start	m3 or tonne
Tot _M	Meter on prove prove total	m3 or tonne
Tot _M (stop)	Indicated totalizer of the meter on prove at prove end	m3 or tonne
Tot _M (start)	Indicated totalizer of the meter on prove at prove start	m3 or tonne
t _{MM}	Time between start and stop from master meter module	sec
t _M	Time between start and stop from meter on prove module	sec

The correction factor t_{MM} / t_M accounts for possible differences in prove time between the master meter flow module / computer and the meter on prove flow module / computer, caused by the fact that both modules have their own independent calculation cycle and possible delays in the start / stop signal.

Meter factor calculation for master meter proving

Both volumetric and mass meters are supported for both the meter on prove and the master meter. Therefore 4 different formulas are used for the 4 possible combinations.

$$MF_P = \frac{V_{MM} \times MF_{MM} \times C_{TLP} \times C_{PLP}}{V_M \times C_{TLM} \times C_{PLM}}$$

Equation 6-42: Prover Meter Factor for master meter proving of a volumetric meter using a volumetric master meter.

$$MF_P = \frac{(M_{MM} \times 1000 / \rho_{MM}) \times MF_{MM} \times C_{TLP} \times C_{PLP}}{V_M \times C_{TLM} \times C_{PLM}}$$

Equation 6-43: Prover Meter Factor for master meter proving of a volumetric meter using a mass master meter.

$$MF_P = \frac{V_{MM} \times (\rho_{MM} / 1000) \times MF_{MM}}{M_M}$$

Equation 6-44: Prover Meter Factor for master meter proving of a mass meter using a volumetric master meter.

$$MF_P = \frac{M_{MM} \times MF_{MM}}{M_M}$$

Equation 6-45: Prover Meter Factor for master meter proving of a mass meter using a mass master meter.

MF _P	Meter factor calculated from proving	-
V _{MM}	Master meter (uncorrected) volume	m3
M _{MM}	Master meter (uncorrected) mass	tonne
MF _{MM}	Meter factor of the master meter (at the proving flow rate)	-
C _{TLP}	Correction for the effects of Temperature on the Liquid at the master meter	-
C _{PLP}	Correction for the effects of Pressure on the Liquid at the master meter	-
V _M	Meter on prove (uncorrected) volume	m3
M _M	Meter on prove (uncorrected) mass	tonne

C _{TLM}	Correction for the effects of Temperature on the Liquid at the meter on prove	-
C _{PLM}	Correction for the effects of Pressure on the Liquid at the meter on prove	-
ρ _{MM}	Meter density of the master meter (density at the master meter conditions)	-

Ethylene

For Ethylene the following calculations apply:

$$C_{TPL} = 1$$

$$Q_{GSV} = Q_{GV} * C_{TPL} = Q_{GV}$$

$$\rho_s = 0$$

$$Q_M = \frac{Q_{GV} * \rho_f}{1000}$$

Equation 6-46: Ethylene equations

C _{TPL}	Combined correction factor	[-]
Q _{GSV}	Gross standard volume flow rate	[sm3/hr]
Q _{GV}	Gross volume flow rate	[m3/hr]
Q _M	Mass flow rate	[tonne/hr]
ρ _s	Standard density	[kg/sm3]
ρ _f	Fluid density at the meter conditions	[kg/sm3]

The fluid density equals the measured density if available. If no measured density is available, the fluid density is calculated according to the applicable standard (IUPAC, API 11.3.2.1 or NIST 1045).

Prove calculations for Ethylene are mass based, regardless of the type of meter (volumetric or mass based) and the setting 'alternative calculation'.

Propylene and water / steam

For Propylene, water and steam the following calculations apply:

$$C_{TPL} = \frac{\rho_{f \text{ calc}}}{\rho_s}$$

$$Q_{GSV} = Q_{GV} * C_{TPL}$$

$$Q_M = \frac{Q_{GV} * \rho_f}{1000}$$

Equation 6-47: Propylene / water / steam equations

C _{TPL}	Combined correction factor	[-]
Q _{GSV}	Gross standard volume flow rate	[sm3/hr]
Q _{GV}	Gross volume flow rate	[m3/hr]
Q _M	Mass flow rate	[tonne/hr]
ρ _s	Standard density	[kg/sm3]
ρ _{f calc}	Fluid density at meter conditions (calculated)	[kg/m3]
ρ _f	Fluid density at the meter conditions	[kg/sm3]

The fluid density ρ_f equals the measured density if available. If no measured density is available, ρ_f is calculated according to API 11.3.3.2).

The standard density ρ_s is either a fixed value from the product table, or calculated from the base pressure and base temperature according to API 11.3.3.2.

7 Reports

Reports of the Flow-X flow computer are freely configurable. The layout of the standard reports can be modified and other user-defined reports may be added. Refer to manual IIA 'Operation and Configuration', chapter 'Reports' for further explanation. Reports are stored on the flow computer's flash disk, where they remain available for a configurable time. Reports can be read from the flow computer display or web browser and they can be retrieved from the flow computer by web requests (see the Flow-X webs services reference manual for details).

Standard reports

The Liquid Metric application provides the following standard reports:

Report name	Report description
MeterTicket	Meter ticket that is generated automatically at the end of the batch if Reverse totals are disabled. Only generated if API 12.2.1 Measurement Tickets compliance, Implement meter factor retroactively, Implement standard density retroactively and Implement BS&W retroactively are all disabled (Display: Configuration, Overall setup, Meter ticket).
MeterTicket_BiDir	Bi-directional meter ticket that is generated automatically at the end of the batch if Reverse totals are enabled. Only generated if API 12.2.1 Measurement Tickets compliance, Implement meter factor retroactively, Implement standard density retroactively and Implement BS&W retroactively are all disabled (Display: Configuration, Overall setup, Meter ticket). Contains both forward and reverse values.
RecalcTicket	This recalculated meter ticket is generated manually at a recalculation command (after entering new values for the standard density, meter factor and/or BS&W), if Reverse totals is disabled. Also generated automatically at the end of a batch if any of the settings API 12.2.1 Measurement Tickets compliance, Implement meter factor retroactively, Implement standard density retroactively or Implement BS&W retroactively is enabled.
RecalcTicket_BiDir	This recalculated meter ticket is generated manually at a recalculation command (after entering new values for the standard density, meter factor and/or BS&W), if Reverse totals is enabled. Also generated automatically at the end of a batch if API 12.2.1 Measurement Tickets compliance, Implement meter factor retroactively, Implement standard density retroactively or Implement BS&W retroactively is enabled. Contains both forward and reverse values.
StationTicket	Station ticket that is generated automatically at the end of a batch if API 12.2.1 Measurement Tickets compliance, Implement meter factor retroactively, Implement standard density retroactively and Implement BS&W retroactively are all disabled. Contains the (forward) values for the station and up to 4 runs.
StationRevTicket	Station ticket that is generated automatically at the end of a batch if API 12.2.1 Measurement Tickets compliance, Implement meter factor retroactively, Implement standard density retroactively and Implement BS&W retroactively are all disabled and Reverse totals is enabled. Contains the (reverse) values for the station and up to 4 runs.
StationRecalcTicket	This recalculated station ticket is generated manually at a recalculation command (after entering new values for the standard density, meter factor and/or BS&W). Also generated automatically at the end of a batch if any of the settings API 12.2.1 Measurement Tickets compliance, Implement meter

Report name	Report description
	factor retroactively, Implement standard density retroactively or Implement BS&W retroactively is enabled. Contains the (forward) values for the station and up to 4 runs.
Run_Daily	Daily report for one run, which is generated automatically at the end of the day if Reverse totals are disabled.
Run_Daily_BiDir	Daily report for one run, which is generated automatically at the end of the day if Reverse totals are enabled. Contains both forward and reverse values.
Stn_Daily	Daily report for the station, which is generated automatically at the end of the day. Shows the (forward) values for the station and up to 4 runs
Stn_Daily_Rev	Daily report for the station, which is generated automatically at the end of the day if Reverse totals are enabled. Shows the reverse values for the station and up to 4 runs
Run_Snapshot	Shows a consistent snapshot of the actual input and calculated values of one run. All values are of the same calculation cycle. Printed on manual command if Reverse totals are disabled.
Run_Snapshot_BiDir	Shows a consistent snapshot of the actual input and calculated values of one run. All values are of the same calculation cycle. Printed on manual command if Reverse totals are enabled. Contains both forward and reverse values.
Stn_Snapshot	Shows a consistent snapshot of the actual input and calculated values of the station and up to 4 runs. Printed on manual command. Shows forward values only.
Stn_Snapshot_BiDir	Shows a consistent snapshot of the actual input and calculated values of the station and up to 4 runs. Printed on manual command if Reverse totals are enabled. Contains both forward and reverse values.
PipeProver	Volume based prove report for pipe provers, using the average data method. Generated automatically at the end of a proving sequence if the prover type is 'bi-directional ball' or 'uni-directional ball', the meter quantity type is 'volume' and the meter factor calculation method is 'Average data method'.
PipeProverMF	Volume based prove report for pipe provers, using the average meter factor method. Generated automatically at the end of a proving sequence if the prover type is 'bi-directional ball' or 'uni-directional ball', the meter quantity type is 'volume' and the meter factor calculation method is 'Average meter factor method'.
PipeProverMass	Mass based prove report for pipe provers, using the average data method. Generated automatically at the end of a proving sequence if the prover type is 'bi-directional ball' or 'uni-directional ball', the meter quantity type is 'mass' and the meter factor calculation method is 'Average data method'.
PipeProverMassMF	Mass based prove report for pipe provers, using the average meter factor method. Generated automatically at the end of a proving sequence if the prover type is 'bi-directional ball' or 'uni-directional ball', the meter quantity type is 'mass' and the meter factor calculation method is 'Average meter factor method'.
CompactProver	Volume based prove report for compact / small volume provers, using the average data method. Generated automatically at the end of a proving sequence if the prover type is 'Calibron / Flow MD' or 'Brooks compact', the meter quantity type is 'volume' and the meter factor calculation method is 'Average data method'.
CompactProverMF	Volume based prove report for compact / small volume provers, using the average meter factor

Report name	Report description
	method. Generated automatically at the end of a proving sequence if the prover type is 'Calibron / Flow MD' or 'Brooks compact', the meter quantity type is 'volume' and the meter factor calculation method is 'Average meter factor method'.
CompactProverMass	Mass based prove report for compact / small volume provers, using the average data method. Generated automatically at the end of a proving sequence if the prover type is 'Calibron / Flow' or 'Brooks compact', the meter quantity type is 'mass' and the meter factor calculation method is 'Average data method'.
CompactProverMassMF	Mass based prove report for compact / small volume provers, using the average meter factor method. Generated automatically at the end of a proving sequence if the prover type is 'Calibron / Flow' or 'Brooks compact', the meter quantity type is 'mass' and the meter factor calculation method is 'Average meter factor method'.
MasterMeter	Volume based prove report for master meter proving (using average meter factor method). Generated automatically at the end of a proving sequence if the prover type is 'Master meter' and the meter quantity type is 'volume'.
MasterMeterMass	Mass based prove report for master meter proving (using average meter factor method). Generated automatically at the end of a proving sequence if the prover type is 'Master meter' and the meter quantity type is 'mass'.
LoadingTicket	Only available for application with added loading functionality. Meter ticket with additional loading info.
LACTTicket	Only available for application with added loading functionality. Meter ticket for LACT systems, including loading, truck and driver information.
Events_Daily	Generated automatically at the end of the day. Shows all events (other than alarm transitions) during the day.
Alarms_Daily	Generated automatically at the end of the day. Shows all alarm transitions during the day.
Configuration	Configuration report that can be printed directly from the flow computer. This report contains an extensive overview of the flow computer's configuration settings. This report uses quite a large amount of memory and must be handled with care when used with version 1 hardware.
ABB_CoriolisMaster	Verification rapport for ABB CoriolisMaster meter. Contains configuration and diagnostical data from the meter. Only applicable to ABB Coriolismaster meters. Generated on demand from the meter displays in the Communication section.

Table 9: Standard reports

In flow-Xpress, generation of specific reports can be enabled or disabled. By default most reports have been disabled. They can be enabled in Flow-Xpress -> Reports, by right clicking on the report and selecting 'Enabled'.

8 Communication

The application contains a number of standard Modbus lists for communication to flow meters, DCS systems, HMI systems, etc. Furthermore a number of standard HART communication lists are available for communication to transmitters and flow meters that support the HART protocol.

To use any of these communication lists, you have to select it in Flow-Xpress 'Ports & Devices' and assign it to the appropriate communication port.



With Flow-Xpress Professional, communication lists can be freely added, modified, extended etc.

Refer to manual IIA 'Operation and Configuration', chapter 'Communication' for more details.

Standard Modbus communication lists

Modbus Tag List

The application provides an overall Modbus communication list that contains all variables and parameters of up to four meter runs, station and proving. This communication list can be used for serial and Ethernet communication.

This Modbus tag list uses a register size of 2 bytes (16 bits) for integer data, a register size of 4 bytes (32 bits) for single precision floating point data (f.e. process values and averages) and a register size of 8 bytes (64 bits) for double precision floating point data (totalizers).

This overall communication list can be used 'as is' or it can be modified if required.

Modbus Tag List 16 bits

This is an abbreviated Modbus tag list, which only includes the most important data, like process values and totalizers. It is mainly meant for communication to older (DCS) systems or PLC's that don't support data addresses larger than 16 bits.

This Modbus tag list uses a register size of 2 bytes (16 bits) for integer data, single precision floating point data (process values) and long integer data (totalizers).



Because with this tag list the totalizers are communicated as long integers, the **totalizer rollover** values should not be set higher than 1.E+09.

Except for the FC time, which can be written for time synchronization, this tag list only contains read data.

This communication list can be used 'as is' or it can be modified if required.

Connect to remote station

Generic Modbus list for communication between a station / proving flow computer and a remote run flow computer. Select this Modbus list on each remote run flow computer that has to communicate to a (remote) station / proving flow computer.

Refer to paragraphs Configuration, Overall setup, Flow computer concepts and Configuration, Proving, Proving setup for more details.

Connect to remote run

Generic Modbus list for communication between a station / proving flow computer and a remote run flow computer. Select this Modbus list on a station / prover flow computer that has to communicate to one or more remote run flow computers. For each remote run flow computer a separate 'Connect to remote run' Modbus list has to be selected.

A station / prove flow computer can communicate to up to 8 remote run flow computers.

Refer to paragraphs Configuration, Overall setup, Flow computer concepts and Configuration, Proving, Proving setup for more details.

Connect to remote prover IO server

Generic Modbus list for communication between a run / proving flow computer and a flow computer that has been configured as 'Remote prover IO server'. Select this Modbus list on each run / prover flow computer that has to communicate to a 'Remote prover IO server'.

Refer to paragraphs Configuration, Overall setup, Flow computer concepts and Configuration, Proving, Proving setup for more details.

Act as remote prover IO server

Generic Modbus list for communication between a run / proving flow computer and a flow computer that has been configured as 'Remote prover IO server'. Select this Modbus list on the 'Remote prover IO server' flow computer, in order to make the prover IO available to each run / prover flow computer that is supposed to use it.

Refer to paragraphs Configuration, Overall setup, Flow computer concepts and Configuration, Proving, Proving setup for more details.

Omni compatible communication list

The application contains the following Omni compatible Modbus list:

- Modbus tag list (Omni v24)
Compatible to Omni v24, max. 4 runs.
- Modbus tag list (Omni v24 bi-dir)
Compatible to Omni v24, bi-directional: 1x fwd, 1x rev

- Modbus tag list (Omni v25)
Compatible to Omni v25, max. 4 runs.

Custom data packets 1, 201 and 401 and historical data archives 701-710 are supported, but must be customized using Flow-Xpress Professional.

Modbus devices

The application by default supports the following Modbus devices:

Flow meters:

- ABB CoriolisMaster Coriolis flow meter
- Micro Motion Coriolis flow meter
- Endress & Hauser Promass Coriolis flow meter
- Caldon LEFM ultrasonic flow meter (4-path)
- Caldon LEFM ultrasonic flow meter (8-path)
- Faure Herman 8400 ultrasonic flow meter

Densitometer:

- Anton Paar

Multivariable transmitters:

- ABB 266 multivariable transmitter
- Rosemount 4088 multivariable transmitter

For Anton Paar densitometers that support the Modbus protocol.

Additional Modbus devices can be configured using Flow-Xpress Professional.

HART devices

The application by default supports the following HART devices:

Flow meters:

- Flow meter HART
Generic communication driver for flow meters that provide a flow rate through HART

Densitometer:

- Anton Paar densitometer
For Anton Paar densitometers that support the HART protocol

Generic HART communication lists for temperature, pressure, dP transmitters etc. that support the HART protocol:

- **HART transmitter (1 var v5).** HART communication list for transmitters that comply with the HART standard version 5. This list only reads the first HART variable. Because for most HART transmitters the first variable is the main process value, this can be used in most cases.
- **HART transmitter (1 var v6).** HART communication list for transmitters that comply with the HART standard version 6. This list only reads the first HART variable. Because for most HART transmitters the first variable is the main process value, this can be used in most cases.
- **HART transmitter (1 var v7).** HART communication list for transmitters that comply with the HART standard version 7. This list only reads the first HART variable. Because for most HART transmitters the first variable is the main process value, this can be used in most cases.
- **HART transmitter (3 var).** HART communication list that reads all variables (for transmitter that comply with the HART standard version 5). Has to be selected if you want to use the 2nd or 3th HART variable from a HART transmitter that supports 3 variables.
- **HART transmitter (4 var).** HART communication list that reads all variables (for transmitter that comply with the HART standard version 5). Has to be selected if you want to use the 2nd, 3th or 4th HART variable from a HART transmitter that supports 4 variables.

Additional HART devices can be configured using Flow-Xpress Professional.

9 Historical Data Archives

Historical Data Archives provide a convenient way to store, view and hand-off all relevant historical batch and period data.

Historical data archives are freely configurable using Flow-Xpress Professional. Existing archives may be modified and new archives may be added.

Historical data archives can be read from the flow computer display or web browser. They can be retrieved from the flow computer as XML files by web requests (see the Flow-X webs services reference manual for details) and they can be read using Modbus. The Flow-X supports the Omni Raw Data Archive RDA polling method (Omni archives 701-710).

Standard Data Archives

The application by default contains the following historical data archives

- **BatchRun**
Contains the data of the meter tickets of the last 100 days (configurable)
- **BatchStn**
Contains the data of station tickets of the last 100 days (configurable)
- **DailyRun**
Contains the data of the meter tickets of the last 100 days (configurable)

10 MID Compliance

Accountable alarms

In compliance with OIML-R117, the metrological standard which is referred to by MID (Measuring Instruments Directive), the Flow-X raises an accountable alarm in the following situations:

- Meter temperature transmitter fail, override value enabled, input forced or in calibration
- Meter pressure transmitter fail, override value enabled, input forced or in calibration
- Density transmitter failure, input forced or in calibration
- Density temperature transmitter fail, override value enabled, input forced or in calibration
- Density pressure transmitter fail, override value enabled, input forced or in calibration
- Differential pressure transmitter failure or ISO5167 / AGA3 calculation failure (dP meters)
- Pulse input failure or forced (pulse meters)
- Meter communication failure, measurement failure or flow rate forced (smart meter)
- Data invalid alarm
- Standard density calculation fail, transmitter fail, override value enabled, input forced or in calibration
- Meter density calculation fail
- Meter pressure lower than the equilibrium pressure plus a configurable offset.
- Flow rate out of accountable limits*
- Meter temperature out of accountable limits*
- Meter pressure out of accountable limits*
- Standard density out of accountable limits*
- Custom accountable alarm, which can be used to add custom, user specific, accountable alarm conditions.

*For these alarms an optional **neutralization amount** is taken into account, in order to avoid accountable alarms at normal start up and shut down.

For this purpose the application provides an additional set of accountable and non-accountable totalizers. If there is no accountable alarm then the accountable totalizers are active and the non-accountable totalizers are inactive. In case of an accountable alarm the non-accountable totalizers are active and the accountable totalizers are inactive. The normal totalizers are active regardless of the accountable alarm.

If needed, the accountable alarm (**Any accountable alarm**) can also be used to stop the flow, by closing a valve or withdrawing the flow control PID permissive, using Flow-Xpress custom calculations.

Apart from the live accountable alarms from the above list, after finishing of a batch the batch size is checked against a **minimum accountable batch size**. If the batch size was too low, a ****Batch size below accountable minimum**** indication is printed on the batch report.

Neutralization

If neutralization is enabled, flow range, temperature range, pressure range and standard density range accountable alarms are delayed until a **neutralization quantity** is reached.

If neutralization is enabled, each time an accountable defect appears a neutralization counter (indicated volume or mass depending on meter quantity type) is started. The accountable totalizers are running, until the counter reaches the **neutralization quantity**, the accountable alarm is set, and the non accountable totalizers start running.

When there is no more pending defect, the non-accountable totalizers stop running and the accountable totalizers start running again. The neutralization counter is reset after the **neutralization reset quantity** is reached without any accountable alarm.

There are two separate neutralization counters: one for the low flow accountable alarm and another one for the temperature range, pressure range, standard density range and high flow accountable alarms.

11 Revisions

Revision A

Date February 2009

- Initial, preliminary release of the Flow-X Manual Volume IIC - Liquid Metric Application.
- Update after final MID approval.

Revision B

Date June 2010

- Second major release describing the added features, such as the historical data archives. Update to application version 1.2.3.

Revision C

Date May 2012

- Complete review of the manual. Major update, describing new functionality of application version 1.3.3.
- Update to application version 1.4.1.S
- Minor editorial changes.

Revision D

Date September 2016

- Major review of the manual. Update to application version 2.1.0.
- Update to application version 2.2.0.

Revision E

Date May 2018

- Update to ABB lay-out
- Update to application version 2.3.0.

Revision F

Date June 2019

- Update to application version 3.0.0.

Revision G

Date June 2020

- Update to application version 3.1.0.
- Added optional loading functionality.

ABB B.V.**Measurement & Analytics**

Achtseweg Zuid 151A
5651 GW Eindhoven
The Netherlands
Phone: +31 40 236 9445
Mail: nl-spiritit-sales@abb.com

ABB Malaysia Sdn Bhd.**Measurement & Analytics**

Lot 608, Jalan SS 13/1K
47500 Subang Jaya
Selangor Darul Ehsan, Malaysia
Phone: +60 3 5628 4888

abb.com/midstream

ABB Inc.**Measurement & Analytics**

7051 Industrial Boulevard
Bartlesville OK 74006
United States of America
Phone: +1 800 442 3097

ABB Limited**Measurement & Analytics**

Oldends Lane, Stonehouse
Gloucestershire, GL10 3TA
United Kingdom
Phone: +44 7730 019 180



We reserve the right to make technical changes or modify the contents of this document without prior notice. With regard to purchase orders, the agreed particulars shall prevail. ABB AG does not accept any responsibility whatsoever for potential errors or possible lack of information in this document.

We reserve all rights in this document and in the subject matter and illustrations contained therein. Any reproduction, disclosure to third parties or utilization of its contents – in whole or in parts – is forbidden without prior written consent of ABB.

© ABB 2020